

MODEL 3660 TWIN-LINE® PLANTER OPERATOR & PARTS MANUAL

M0217

Rev. 12/09

This manual is applicable to: Model: 3660 Twin-Line® Planters

Record the model number and serial number of your planter along with date purchased:

Model Number _____ 3660 _____

Serial Number _____

Date Purchased _____

SERIAL NUMBER

The serial number plate is located on the planter frame to be readily available. It is suggested that your serial number and purchase date also be recorded above.

The serial number provides important information about your planter and may be required to obtain the correct replacement part. Always provide the model number and serial number to your KINZE® Dealer when ordering parts or anytime correspondence is made with KINZE Manufacturing, Inc.

D032509204

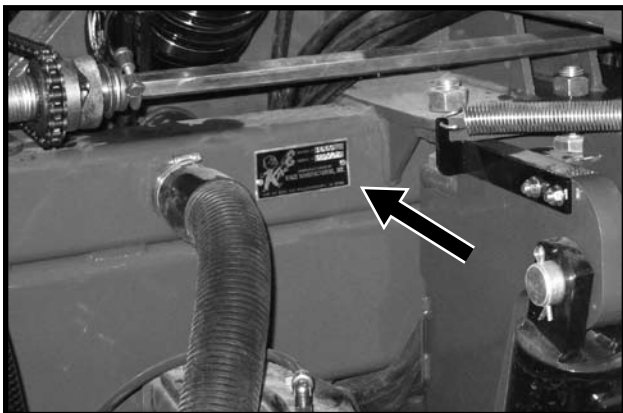

Prior to 2010 Production

D07020908a

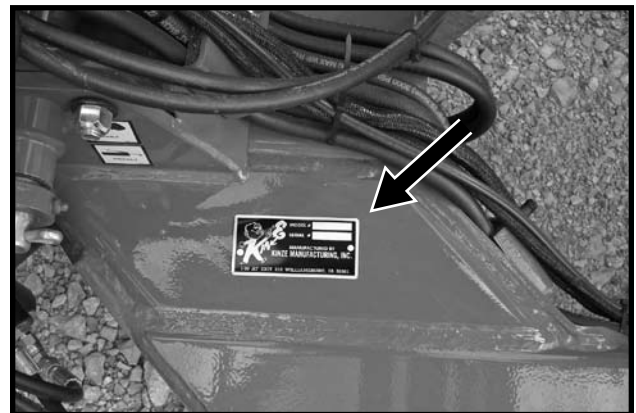

2010 Production and on

KINZE®, the KINZE® logo, Twin-Line®, Interplant®, EdgeVac®, KINZE Vision® and Cobalt™ are trademarks of KINZE Manufacturing, Inc.

Rev. 8/09

This page left blank intentionally.

PREDELIVERY / DELIVERY CHECKLIST

TO THE DEALER

Predelivery service includes assembly, lubrication, adjustment and test. This service helps to ensure that the planter will be delivered to the customer ready for field use.

PREDELIVERY CHECKLIST

After the planter has been completely assembled, use the following checklist and inspect the planter. Check off each item as it is found satisfactory or after proper adjustment is made.

- Recheck to be sure row units are properly spaced and optional attachments are correctly assembled.
- The row marker blade assemblies have been removed from their shipping location over the planter hitch and installed on the row marker assembly at each end of the planter. See "Row Marker Length Adjustment" in the Machine Operation Section of this manual.
- Be sure all grease fittings are in place and lubricated.
- Check planter and make sure all working parts are moving freely, bolts are tight and cotter pins are spread.
- Check all drive chains for proper tension and alignment.
- Check for oil leaks and proper hydraulic operation.
- Check to be sure hydraulic hoses are routed correctly to prevent damage.
- Inflate tires to specified PSI air pressure. Tighten wheel lug bolts and lug nuts to specified torques.
- Check to be sure all safety decals are correctly located and legible. Replace if damaged.
- Check to be sure all reflective decals and SMV sign are correctly located and visible when the planter is in transport position.
- Check to be sure safety/warning lights are installed correctly and working properly.
- Paint all parts scratched in shipment or assembly.
- Be sure all safety lockup devices are on the planter and correctly located.
- Auxiliary safety chain is properly installed and hardware is torqued to specification.
- Vacuum fan PTO-driven pump is attached correctly to the tractor. Oil reservoir is filled to capacity and system is inspected for leaks. (If Applicable)
- Check that all bolts and fasteners used to assemble and attach entrapment device are tight (if applicable).

This planter has been thoroughly checked and to the best of my knowledge is ready for delivery to the customer.

(Signature Of Set-Up Person/Dealer Name/Date)

OWNER REGISTER

Name _____ Delivery Date _____
Street Address _____ Model No. 3660 Serial No. _____
City, State/Province _____ Dealer Name _____
ZIP/Postal Code _____ Dealer No. _____

DELIVERY CHECKLIST

At the time the planter is delivered, the following checklist is to be used as a reminder of very important information which should be conveyed to the customer. Check off each item as it is fully explained to the customer.

- Advise the customer that the life expectancy of this or any other machine is dependent on regular lubrication as directed in the Operator & Parts Manual.
- Check for proper operation of vacuum fan and PTO drive pump (If Applicable) with tractor to be used with planter.
- Tell the customer about all applicable safety precautions.
- Along with the customer, check to be sure the reflective decals and SMV sign are clearly visible with the planter in transport position and attached to the tractor. Check to be sure safety/warning lights are in working condition. Tell the customer to check federal, state/provincial and local regulations before towing or transporting on a road or highway.
- Give the Operator & Parts Manual to the customer and explain all operating adjustments.
- Read warranty to customer.
- Complete Warranty And Delivery Report form.

To the best of my knowledge this machine has been delivered ready for field use and customer has been fully informed as to proper care and operation.

(Signature Of Delivery Person/Dealer Name/Date)

AFTER DELIVERY CHECKLIST

The following is a list of items we suggest to check during the first season of use of the equipment.

- Check with the customer as to the performance of the planter.
- Check with the customer as to the performance of the EdgeVac® Seed Metering System.
- Review with the customer the importance of proper maintenance and adherence with all safety precautions.
- Check for parts that may need to be adjusted or replaced.
- Check to be sure all safety warning signs (decals), reflective decals and SMV sign are correctly located and that decals are legible. Replace if damaged or missing.
- Check to be sure safety/warning lights are working properly.

(Signature Of Follow-Up Person/Dealer Name/Date)

**RETURN THIS COMPLETED FORM TO KINZE® IMMEDIATELY along with Warranty And Delivery Report.
Retain photocopy of this form at dealership for After Delivery Check.**

Tear Along Perforation

TABLE OF CONTENTS

PREDELIVERY / DELIVERY CHECKLIST	1-1
TO THE OWNER	1-1
WARRANTY	1-2
INTRODUCTION	2-1
SPECIFICATIONS	3-1
SAFETY PRECAUTIONS	4-1
SAFETY WARNING SIGNS	5-1

MACHINE OPERATION

Row Marker Safety Lockup	6-1
Safety Stand	6-1
Tongue Safety Pin	6-2
Transport Latch Locking Pin	6-2
Initial Preparation of the Planter	6-3
Tractor Requirements	6-3
PTO Pump Drive and Oil Cooler Option - Tractor Mounted	6-4
Pump Drive and Oil Cooler Option - Planter Mounted	6-5
Tractor Preparation and Hookup	6-6
Leveling the Planter	6-8
Tire Pressure	6-10
Ridge Planting	6-10
Control Console Operation	6-11
Transport to Field Sequence	6-12
Field Lift Operation	6-14
Field to Transport Sequence	6-15
Digital Vacuum Gauge	6-18
Analog Vacuum and Pressure Gauges	6-18
Air Seed Delivery System	6-19
ASD Entrainer Access	6-20
ASD Tanks - Clean Out	6-21
Vacuum Fan Motor Valve Block Assembly	6-21
ASD Scale Package Option	6-22
Row Marker Operation	6-25
Row Marker Speed Adjustment	6-26
Row Marker Length Adjustment	6-27
KINZE COBALT™ System	6-29
KINZE VISION® System	6-29
Planter Monitor Module (PMM)	6-31
Hydraulic Weight Transfer Toolbar	6-31
Hydraulic Seed Rate Drive	6-31
Row Unit Air Clutches	6-31
Auxiliary Work Lights Package	6-31
Even-Row Push Row Unit	6-32
Auxiliary Hydraulic Option	6-32
Double Disc Fertilizer Opener	6-33

TABLE OF CONTENTS

Notched Single Disc Fertilizer Opener	6-34
Residue Wheel Attachment for Notched Single Disc Fertilizer Opener	6-36
Depth / Gauge Wheel Attachment for Notched Single Disc Fertilizer Opener	6-36
HD Single Disc Fertilizer Opener	6-37
Liquid Fertilizer Attachment	6-38
Transporting the Planter	6-41
Metric Conversion Table	6-41
Hall Effect Sensor	6-41
Planting Speed	6-42
Field Test	6-42
Rear Trailer Hitch	6-43
Checking Seed Population	6-44
Checking Granular Chemical Application Rate	6-45

ROW UNIT OPERATION

Planting Depth	7-1
“V” Closing Wheel Adjustment (Rubber and Cast Iron)	7-1
Closing Wheel Shield (Rubber and Cast Iron “V” Closing Wheels)	7-2
Covering Discs / Single Press Wheel Adjustment	7-2
Drag Closing Attachment	7-3
Seed Hoppers	7-4
Row Unit Extension Brackets	7-5
Seed Meter Drive Release	7-5
Quick Adjustable Down Force Springs Option	7-6
Pneumatic Down Pressure Package Option	7-8
Frame Mounted Coulter	7-11
Residue Wheels (For Use With Frame Mounted Coulter)	7-12
Row Unit Mounted Disc Furrower	7-12
Row Unit Mounted Bed Leveler	7-13
Row Unit Mounted Residue Wheel	7-13
Row Unit Mounted No Till Coulter	7-15
Coulter Mounted Residue Wheels	7-15
Granular Chemical Hopper and Drive	7-16
Granular Chemical Banding Options	7-16
Granular Chemical Bander Shield	7-17
Spring Tooth Incorporator	7-17
Interplant® Push Row Unit Lockups	7-18
Interplant® Push Row Unit Clutch	7-19
Interplant® Push Row Unit Vacuum Hose Shutoff	7-19

SEED METER OPERATION

General Planting Rate Information (Mechanical Seed Metering)	8-1
Finger Pickup Seed Meter	8-2
Brush-Type Seed Meter	8-3
General Planting Rate Information (EdgeVac® Seed Metering)	8-5

TABLE OF CONTENTS

EdgeVac® Seed Meter	8-6
Lubrication - Conventional Hoppers.	8-8
Lubrication - ASD Hoppers	8-8
Seed Meter Cleanout.	8-9
Seed Meter Singulator Brush and Vacuum Level Adjustments	8-10

LUBRICATION

Lubrication Symbols	9-1
Sealed Bearings	9-1
PTO Pump Shaft Coupling (PTO Pump Drive and Oil Cooler Option).	9-1
Air Clutch Cleaning and Lubrication	9-2
Air Clutches	9-3
Drive Chains	9-4
Bushings	9-5
Interplant® Push Row Unit Lockups	9-6
Wheel Bearings	9-7
U-Joint Slides.	9-7
Center Post	9-7
Liquid Fertilizer Piston Pump Crankcase Oil Level	9-7
Grease Fittings	9-8
Planter Mounted PTO Pump Driveline.	9-10

MAINTENANCE

Mounting Bolts and Hardware	10-1
Torque Values Chart - Plated Hardware	10-1
Tire Pressure	10-2
Finger Pickup Seed Meter Inspection / Adjustment.	10-3
Finger Pickup Seed Meter Cleaning	10-4
Finger Pickup Seed Meter Troubleshooting	10-5
Brush-Type Seed Meter Maintenance	10-6
Brush-Type Seed Meter Troubleshooting.	10-8
EdgeVac® Seed Meter Maintenance	10-9
Vacuum Manifold Maintenance	10-9
EdgeVac® Seed Metering System Troubleshooting	10-10
Planter Mounted Pump Drive and Oil Cooler Option	10-12
Tractor Mounted PTO Pump Drive and Oil Cooler Option	10-13
PTO Pump Drive and Oil Cooler Option Troubleshooting	10-13
Closing Wheel Troubleshooting	10-14
Drag Closing Attachment.	10-14
Gauge Wheel Arm Bushing and / or Seal Replacement	10-15
Gauge Wheel Arm Pivot Spindle Replacement	10-15
15" Seed Opener Disc Blade / Bearing Assembly	10-16
Seed Tube Guard / Inner Scraper	10-17
Frame Mounted Coulter	10-17
Row Unit Mounted Bed Leveler	10-18

TABLE OF CONTENTS

Row Unit Mounted Residue Wheel	10-19
Row Unit Mounted No Till Coulter	10-19
Coulter Mounted Residue Wheels	10-19
Granualr Chemical Attachment	10-20
Spring Tooth Incorporator	10-20
Check Valve Inspection (Located in Valve Block Below Vacuum Fan Motor Assembly)	10-21
Check Valve	10-21
Relief Valve Cartridge Inspection (Located in Valve Block Below Vacuum Fan Motor Assembly)	10-21
Flow Control Valve Inspection	10-21
Pressure Relief Valve Inspection	10-21
Pressure reducing / relieving valve inspection	10-21
Solenoid Valve Inspection	10-22
Solenoid Valve Troubleshooting	10-22
Lift Circuit Troubleshooting.	10-23
Tongue Cylinder Circuit Troubleshooting	10-24
Rotation Cylinder Circuit Troubleshooting	10-25
Wing Lock Cylinder Circuit Troubleshooting.	10-25
Row Marker Operation Troubleshooting.	10-26
Row Marker Bearing Lubrication or Replacement.	10-27
Wheel Bearing Lubrication or Replacement	10-27
Rockshaft to Hitch Shim Adjustment	10-28
Center Frame Relation to Inner Hitch Adjustments	10-28
Triangulate Planter and Set Squareness	10-31
Rotation Stop Block - Install.	10-32
Inspect and Adjust Rotation Cylinder Mount	10-33
Piston Pump Storage.	10-34
Pison Pump Troubleshooting	10-34
Preparation for Storage	10-35
Electrical Wiring Diagram for Light Package	10-36
Electrical Control Console Schematic	10-37
Electrical Wiring Harness Schematic (On Tractor).	10-38
Electrical Wiring Harness Schematic (On Planter)	10-39
Valve Block - Located On Hitch	10-40
Valve Block - Located On Rear Center Frame.	10-41
Hydraulic System Schematic	10-42
Hydraulic Schematic - Vacuum Fan Motor System	10-46
Hydraulic Schematic - Optional PTO Pump Drive and Oil Cooler System (Tractor Mounted)	10-47
Hydraulic Schematic - Optional PTO Pump Drive and Oil Cooler System (Planter Mounted).	10-48
Air Line Schematic With Interplant.	10-49
PARTS SECTION	P1
NUMERICAL INDEX	P209

TO THE OWNER

KINZE Manufacturing, Inc. would like to thank you for your patronage. We appreciate your confidence in KINZE® farm machinery. Your KINZE® planter has been carefully designed to provide dependable operation in return for your investment.

This manual has been prepared to aid you in the operation and maintenance of the planter. It should be considered a permanent part of the machine and remain with the machine when you sell it.

It is the responsibility of the user to read and understand the Operator & Parts Manual in regards to safety, operation, lubrication and maintenance before operation of this equipment. It is the user's responsibility to inspect and service the machine routinely as directed in the Operator & Parts Manual. We have attempted to cover all areas of safety, operation, lubrication and maintenance; however, there may be times when special care must be taken to fit your conditions.

Throughout this manual the symbol  and/or the words **NOTE, IMPORTANT, CAUTION, WARNING** or **DANGER** are used to call your attention to important information. The definition of each of these terms follows:

NOTE: Indicates a special point of information or addresses a machine adjustment.

IMPORTANT: Indicates an operation or maintenance condition which, if not corrected, could result in damage to machine, property, crops or environment.

 **CAUTION:** Indicates a potentially hazardous situation which, if not avoided, may result in minor or moderate personal injury.

 **WARNING:** Indicates a potentially hazardous situation which, if not avoided, could result in death or serious personal injury.

 **DANGER:** Indicates an imminently hazardous situation which, if not avoided, will result in death or serious personal injury.

 **WARNING:** Some photos in this manual may show safety covers, shields or lockup devices removed for visual clarity. **NEVER OPERATE** the machine without all safety covers, shields and lockup devices in place.

NOTE: Some photos in this manual may have been taken of prototype machines. Production machines may vary in appearance.

NOTE: Some photos and illustrations in this manual show optional attachments installed. Contact your KINZE® Dealer for purchase of optional attachments.

WARRANTY

The KINZE® Limited Warranty for your new machine is stated on the back of the retail purchaser's copy of the Warranty And Delivery Report form. Additional copies of the Limited Warranty can be obtained through your KINZE® Dealer.

Warranty, within the warranty period, is provided as part of KINZE's support program for registered KINZE® products which have been operated and maintained as described in this manual. Evidence of equipment abuse or modification beyond original factory specifications will void the warranty. Normal maintenance, service and repair is not covered by KINZE® warranty.

To register your KINZE® product for warranty, a Warranty And Delivery Report form must be completed by the KINZE® Dealer and signed by the retail purchaser, with copies to the Dealer, to the retail purchaser and to KINZE Manufacturing, Inc. Registration must be completed and sent to KINZE Manufacturing, Inc. within 30 days of delivery of the KINZE® product to the retail purchaser. KINZE Manufacturing, Inc. reserves the right to refuse warranty on serial numbered products which have not been properly registered.

If service or replacement of failed parts which are covered by the Limited Warranty are required, it is the user's responsibility to deliver the machine along with the retail purchaser's copy of the Warranty And Delivery Report to the KINZE® Dealer for service. KINZE® warranty does not include cost of travel time, mileage, hauling or labor. Any prior arrangement made between the Dealer and the retail purchaser in which the Dealer agrees to absorb all or part of this expense should be considered a courtesy to the retail purchaser.

KINZE® warranty does not include cost of travel time, mileage, hauling or labor.

INTRODUCTION

The Model 3660 Twin-Line[®] planter is available with EdgeVac[®] or mechanical meters, conventional hoppers or Air Seed Delivery system (ASD), Interplant[®], liquid fertilizer, and various other options. Refer to the Specifications section for package configuration details.

GENERAL INFORMATION

The information used in this manual was current at the time of printing. However, due to KINZE's ongoing product improvement, production changes may cause your machine to appear slightly different in detail. KINZE Manufacturing, Inc. reserves the right to change specifications or design without notice and without incurring obligation to install the same on machines previously manufactured.

Right hand (R.H.) and left hand (L.H.), as used throughout this manual, are determined by facing in the direction the machine will travel when in use unless otherwise stated.

D07140821

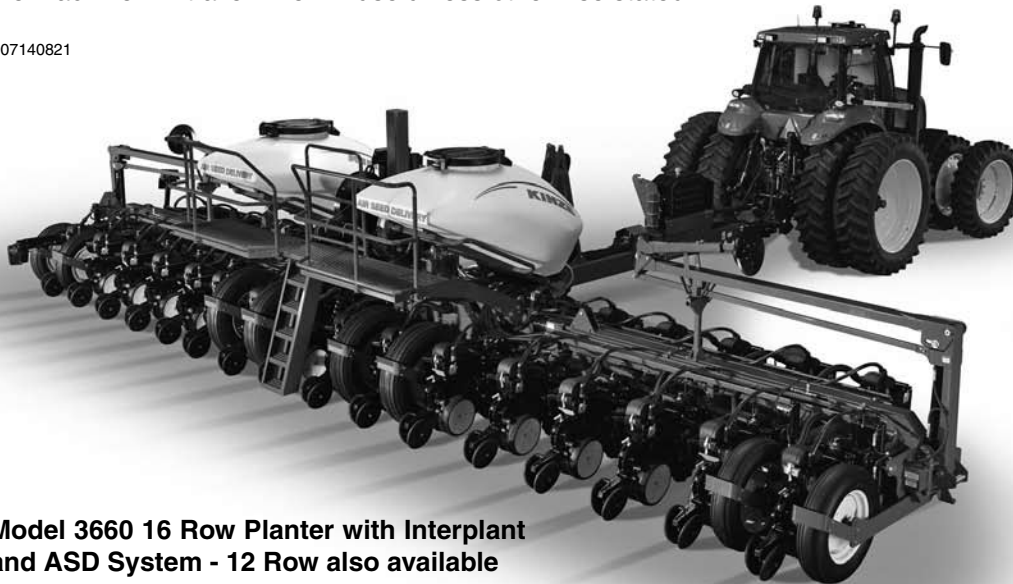

Model 3660 16 Row Planter with Interplant and ASD System - 12 Row also available

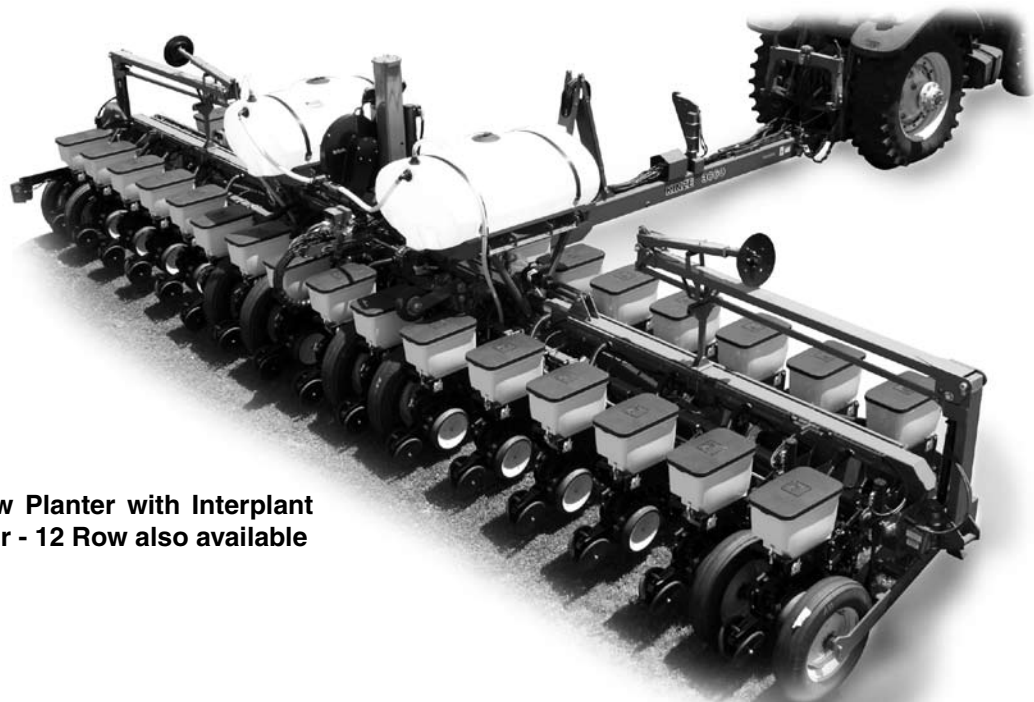

Model 3660 16 Row Planter with Interplant and Liquid Fertilizer - 12 Row also available

INTRODUCTION

This page intentionally left blank.

SPECIFICATIONS

Configurations

Feature	Conventional Hopper		Air Seed Delivery (ASD)		Air Seed Delivery (ASD) Two-Section	
	12 / 16	23 / 31	12 / 16	23 / 31	12 / 16	23 / 31
Interplant® Package with Interplant® PMM Monitor Package	---	•	---	•	---	•
PMM Electronic seed monitoring with harness and “smart” seed sensors	•	•	•	•	•	•
Seed rate control module with single motor hydraulic drive, required harnesses, and speed sensors.	•	•	•	•	•	•
Air clutch control module with drill shaft mounted single row air clutches (4-sections), electric-over-air valves and 50 psi maximum mini-regulator.	•	•	•	•	---	---
Clutch control module with two drill shaft mounted electronically operated wrap spring clutches (allows half width planting control)	---	---	---	---	•	•
12 VDC air compressor with integral air tank, mounting components, shields, and tractor power harness.	•	•	•	•	•	•
Hydraulic weight transfer mechanism to balance weight across width of toolbar.	•	•	•	•	•	•
Rockshaft lift mechanism for increased field raise height.	•	•	•	•	•	•
Air Seed Delivery (ASD) System featuring two centrally mounted 55 bushel seed hoppers (110 bushels total), hydraulically operated fan with hoses, mounting brackets, required fittings, and large catwalk with ladder.	---	---	•	•	•	•
KINZE Vision® Display.	•	•	•	•	---	---
KINZE Cobalt™ Display.	•	•	•	•	•	•
EdgeVac® Seed meters.	•	•	•	•	•	•
Three-section break-away row markers.	•	•	•	•	•	•
Rubber “V” closing wheels (16 or 31 pair - depending upon package).	•	•	•	•	•	•
Pneumatic Down Pressure package for KINZE pull-row units.	•	•	•	•	•	•
Quick-adjustable down force springs for Interplant® push-row units.	•	•	•	•	•	•
Tractor mounted PTO pump and oil cooler.	•	•	•	•	•	•

SPECIFICATIONS

Tractor Hydraulic Requirements

Configuration	No Optional Pumps		Tractor Mounted Pump		Planter Mounted Pump	
	No. SCV	Flow (gpm min.)	No. SCV	Flow (gpm min.)	No. SCV	Flow (gpm min.)
Mechanical Meter	3 SCV	20 gpm min.	N/A	N/A	N/A	N/A
EdgeVac* Meter	4 SCV	40 gpm min.	3 SCV	25 gpm min.	N/A	N/A
ASD (with Mechanical Meter)	4 SCV	40 gpm min.	3 SCV	25 gpm min.	N/A	N/A
ASD (with EdgeVac)	5 SCV	55 gpm min.	4 SCV	40 gpm min.	3 SCV	25 gpm min.

*External case drain required for EdgeVac hydraulic circuits when no optional pumps are used.

Pump PTO Requirements: *Tractor mounted* - 1000 rpm, 1 3/8" diameter shaft. *Planter mounted* - 1000 rpm, 1 3/4" diameter shaft.

Tractor Horsepower Requirement: To effectively operate a fully optioned (ASD, Interplant®, EdgeVac®) 3660 planter, a 225 horsepower Class tractor is required.

SPECIFICATIONS

Specifications

Specification	Conventional Hoppers		Air Seed Delivery (ASD)	
	12	16	12	16
Number of Rows	12	16	12	16
Weight Empty (Mechanical)	15,450 lb.	17,920 lb.	17,040 lb.	19,920 lb.
Weight Empty (EdgeVac®)	15,450 lb.	18,400 lb.	17,450 lb.	20,400 lb.
Hitch Weight Empty	4,100 lb.	4,100 lb.	4,300 lb.	4,300 lb.
Transport Height	11'-11"	11'-11"	11'-11"	11'-11"
Operation Length	23'1"	26' 1"	23'1"	26' 1"
Transport Length	39' 10"	49' 10"	39' 10"	49' 10"
Operation Width	35' 2"	45' 2"	35' 2"	45' 2"
Transport Width	11'-2"	11'-2"	11'-2"	11'-2"
Seed Capacity	1.75 bu. (EdgeVac) / hopper 1.90 bu. (Mechanical) / hopper		110 bu.	
ASD Fill Dimensions (planting position)	N/A		8'5"	
Transport Tire Size	(4) 41" x 11" R22.5", Load Range H, Tubeless Rib Implement			
Transport Tire Pressure	75 psi			
Field Tire Size	(4) 7.5" x 20", 8-ply, Tubeless Rib Implement			
Field Tire Pressure	40 psi			
Field Lift	Master / Slave Hydraulics: 2 center field lift (rockshaft) master cylinders; 4 wing wheel slave cylinders.			
Row Markers	Independently controlled, three stage, low profile equipped disk blade depth bands.			

SPECIFICATIONS

Key Features

- **Improved Hitch Clearance** – The 3660 has an additional eight inches of hitch clearance over other Twin-Line® models.
- **Centrally Located Seed Hoppers** – Air Seed Delivery (ASD) uses two centrally-mounted seed hoppers capable of holding a total of 110 bushels. Operators spend less time filling hoppers and more time planting.
- **Hydraulic Weight Transfer Mechanism** – Features a hydraulic weight transfer mechanism that transfers weight from the center of planter to the wings. This maintains even pressure along the length of the toolbar and prevents the toolbar wings from rising out of the ground. Throughout changing field conditions a consistent seed trench depth is maintained – a key factor for good crop yields.
- **Optional Row Marker Package** – A new row marker design has been utilized on the 3660 for added durability and reliability. Hydraulic cylinders have been moved from beneath to on top to prevent damage and wear from heavy crop residue.
- **Row Marker Breakaway Feature** – The updated row markers also have a “breakaway” feature that allows them to fold back when they hit an obstruction. This prevents costly damage and allows the operator to continue planting. The marker is returned to service again by simply replacing two shear-bolts.
- **Clean Toolbar Design** – The toolbar has been redesigned for a fresh and clean appearance. Vacuum manifolds have been integrated into the toolbar; hydraulic and electrical lines have been encased for protection and organization.
- **Single Row Air Clutches** – These are installed in 4-row sections and allow the row sections to be shut-off manually, or automatically from a GPS map. The savings in seed with this system is significant – saving money and improving the bottom line, and it can all be done automatically.
- **Frame Flexibility** – Due to the larger 6-row center frame, the 3660 frame has additional flexibility over previous Twin-Line® designs – 13° up and 13° down movement. This translates into easier planting in fields with rolling terrain and terraces.
- **Hydraulic Drive** – Features a single motor hydraulic driveline that enables the grower to adjust planting rates from the tractor seat, or by GPS map.

Options

- Interplant® Even Row Push Unit
- Interplant® Air Clutches
- Mechanical Finger Meters
- Cast Iron Closing Wheels
- Quick-Adjustable Down Force Springs
- KINZE Vision® Display
- KINZE Cobalt™ Display
- GPS 1500 Receiver
Used with KINZE Vision® Display
- 2-Point Hitch
Cannot be used with planter mounted PTO driven hydraulic pump.
- Planter-Mounted 2-Section Hydraulic Pump
- Liquid Fertilizer System
*Conventional: Two 300 gallon tanks.
ASD: Two 200 gallon tanks and one 150 gallon tank.*
- Liquid Fertilizer Openers
- Liquid Fertilizer Pump
- Brush Meters
- Granular Chemical Attachments
- Various Row-Unit Attachments
- Electrically operated point row clutches for two-section control of rows.

SAFETY PRECAUTIONS

Safe and careful operation of the tractor and planter at all times will contribute significantly to the prevention of accidents.

Since a large portion of farm accidents occur as a result of fatigue or carelessness, safety practices should be of utmost concern. Read and understand the instructions provided in this manual and on the warning signs. Review these instructions frequently! Listed below are other safety suggestions that should become common practice.

 **Never allow the planter to be operated by anyone who is unfamiliar with the operation of all functions of the unit. All operators should read and thoroughly understand the instructions given in this manual prior to moving the unit.**

 **Never permit any persons other than the operator to ride on the tractor.**

 **Never ride on the planter or allow others to do so.**

 **Always make sure there are no persons near the planter when row marker assemblies are in operation or when rotating the planter.**

 **Always keep hands, feet and clothing away from moving parts. Do not wear loose-fitting clothing which may catch in moving parts.**

 **Always wear protective clothing, substantial shoes and suitable hearing and eye sight protectors applicable for the situation.**

 **Do not allow anyone to stand between the tongue or hitch and the towing vehicle when backing up to the planter.**

 **Be aware of bystanders, particularly children! Always look around to make sure it is safe to start the engine of the towing vehicle or move the planter. This is particularly important with higher noise levels and quiet cabs, as you may not hear people shouting.**

 **Use a tractor equipped with a roll-over-protective-system and fasten your seat belt prior to starting the engine.**

 **Before operating the planter for the first time and periodically thereafter, check to be sure the lug bolts on the transport wheels are torqued properly. This is especially important if the planter is to be transported for a long distance.**

 **Never work under the planter while in raised position without using manual safety lockup.**

 **Install safety lockup devices on markers prior to transporting the planter or working around the unit.**

D021909220

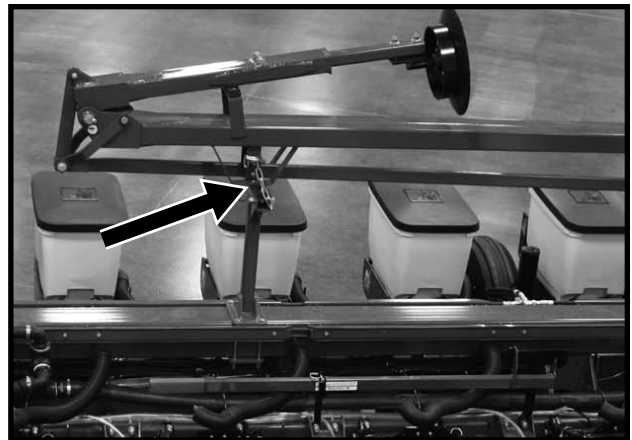

Row Marker Lockup

 **Watch for obstructions such as wires, tree limbs, etc. when folding markers.**

 **To avoid serious injury or death, care must be taken when operating row markers around overhead power lines.**

 **On machines where the outer transport wheel on the left side of the planter is bolt-on to allow legal width truck shipment, always install outer transport wheel assembly prior to unloading. DO NOT REMOVE THIS ASSEMBLY AFTER PLANTER IS ASSEMBLED FOR USE. DO NOT fold planter or tow planter while the outer transport wheel is removed. Tipping may occur because of narrow wheel base.**

 **Hydraulic motors power the fans for the seed distribution and vacuum systems and the seed metering drive system. The use of aftermarket hydraulic, electric or PTO drives may create serious safety hazards to you and others nearby. Always follow all appropriate safety standards and practices to protect you and others near this planter from injury.**

SAFETY PRECAUTIONS

 Always install tongue safety pin, manual safety stand and transport latch locking pin before transporting planter.

D013009214/D013009215

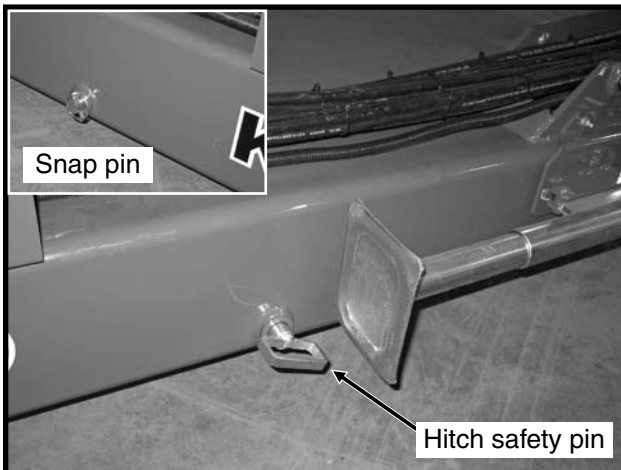

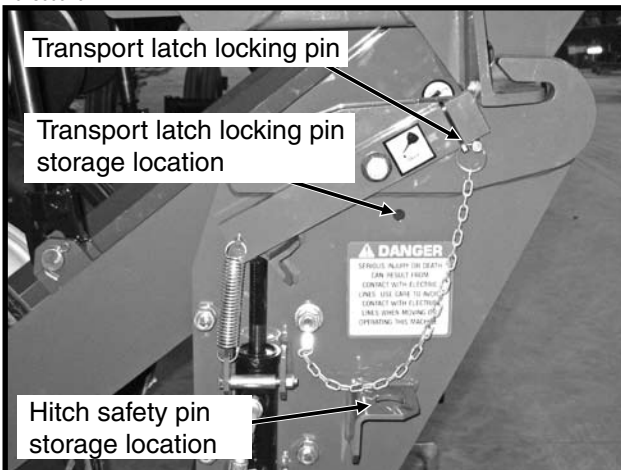

Tongue Safety Pin

D013009204



Safety Pin Storage Locations

 This machine has been designed and built with your safety in mind. Do not make any alterations or changes to this machine. Any alteration to the design or construction may create safety hazards.

 Always follow federal, state/provincial and local regulations when towing farm equipment on a public highway. Only a safety chain (not an elastic or nylon/plastic tow strap) should be used to retain the connection between the towing and towed machines in the event of separation of the primary attaching system.

 Check to be sure all safety/warning lights are working properly before transporting the machine on public roads.

 Avoid transporting loaded planter whenever possible. When it is necessary to transport the planter with the hoppers loaded, the added weight should be distributed evenly on the planter frame before rotating the planter.

 Limit towing speed to 15 MPH.

 Transport stability is critical. The gross weight of the tractor must be greater than the gross weight of the planter. Gross weight varies with planter attachments. Tow 16 Row 30" planters with farm tractor of a minimum 200 HP.

 Always make sure safety/warning lights, reflective decals and SMV sign are in place and visible prior to transporting the machine on public roads. In this regard, check federal, state/provincial and local regulations.

 Allow for unit length when making turns.

 Always drive at a safe speed relative to local conditions and ensure your speed is low enough for an emergency stop to be safe and secure. Keep speed to a minimum.

 Reduce speed prior to turns to avoid the risk of overturning.

SAFETY PRECAUTIONS

 Always keep the tractor in gear to provide engine braking when going downhill. Do not coast.

 Avoid sudden uphill turns on steep slopes.

 Be a safe and courteous driver. Always yield to oncoming traffic in all situations, including narrow bridges, intersections, etc.

 Rim and tire servicing can be dangerous. Explosive separation of a tire and rim parts can cause serious injury or death.

 Agricultural chemicals used with this unit can be dangerous. Improper selection or use can seriously injure persons, animals, plants, soil and other property. **BE SAFE:** Select the right chemical for the job. Handle it with care. Follow the instructions on the container label and of the equipment manufacturer.

 Store the planter in an area away from human activity. **DO NOT** permit children to play on or around the stored unit.

 Make sure the parked machine is on a hard, level surface. Wheel chocks may be needed to prevent unit from rolling.

 Never operate vacuum fan with cover removed.

 Always wear ear protection when working around operating vacuum fan.

 Pressurized hydraulic fluid can penetrate body tissue and result in serious infection, injury, or death. Before applying pressure to the hydraulic system, make sure all connections are tight and that hoses and fittings have not been damaged. Leaks can be invisible. Keep away from suspected leaks. Relieve pressure in the hydraulic system before searching for leaks, disconnecting hoses, or performing any other work on the system. Fluid injected under the skin must be **IMMEDIATELY** removed by a surgeon familiar with this type of injury.

 Planter hydraulic drive system can start at any time. Entanglement with driveline components can cause severe personal injury or death. Fully shut down tractor and neutralize hydraulic lines before adjusting or servicing planter hydraulic drive system.

 Attempting to open air seed delivery hopper lid when system is pressurized can cause lid to open suddenly. Impact from lid can cause personal injury. Shut down pressure fan and allow system to depressurize before opening lid.

 Seed in delivery tubes is moving at high velocity. Seed flying out of disconnected delivery tube can cause personal injury. Do not disconnect delivery tubes when system is operating.

SAFETY PRECAUTIONS 

This page left blank intentionally.

SAFETY WARNING SIGNS

The “WARNING” signs illustrated on these pages are placed on the machine to warn of hazards. The warnings found on these signs are for your personal safety and the safety of those around you. **OBSERVE THESE WARNINGS!**

- **Keep these signs clean so they can be readily observed. Wash with soap and water or cleaning solution as required.**
- **Replace “WARNING” signs should they become damaged, painted over or if they are missing.**
- **Check reflective decals and SMV sign periodically. Replace if they show loss of any of their reflective properties.**
- **When replacing decals, clean the machine surface thoroughly using soap and water or cleaning solution to remove all dirt and grease.**

NOTE: Style and locations of SMV sign, reflective decals and safety/warning lights conform to ANSI/ASAE S279.13 DEC2005 and ANSI/ASAE S276.6 JAN2005.

D01290904



Part No. G7100-117 (Qty. 1)



Part No. G7100-02 (Qty. 1)

D01290905



Part No. G7100-75
(Qty. 4 - Two on each side of top frame member - front and back - beneath and to the side of each hopper.)

SAFETY WARNING SIGNS

D01290922a



Part No. G7100-200
(Qty. 2 - Two on each side of planter.)



Part No. G7100-68
(Qty. 2 - Two on center frame; one on front - one on back.)

D01290908

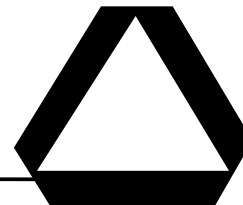

Part No. GD2199 (Qty. 1)



Part No. G7100-68
(Qty. 2 - One on each end of planter.)



Part No. G7100-63
(Qty. 2 - One on each end of planter.)

SAFETY WARNING SIGNS

D09030908

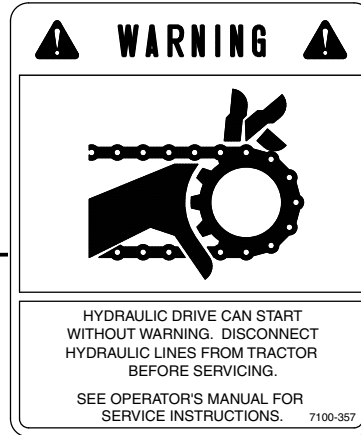

Part No. G7100-357
(Qty. 2 - One on each end of hydraulic drive shaft.)

D013109258

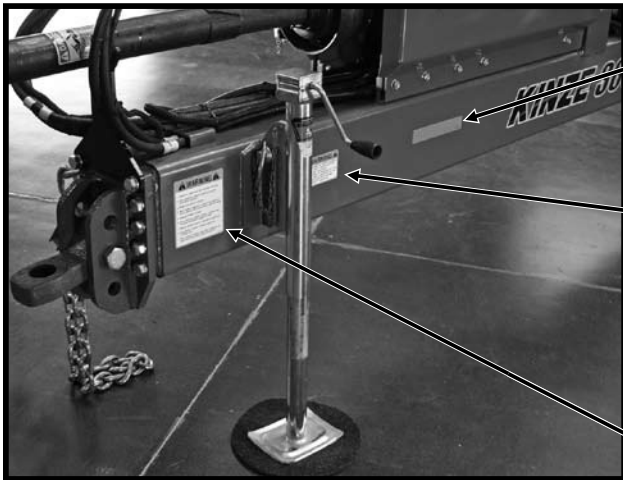

Part No. G7100-259 Amber Reflective Decal
(Qty. 2 - One on each side of hitch.)



Part No. G7100-90 (Qty. 1)

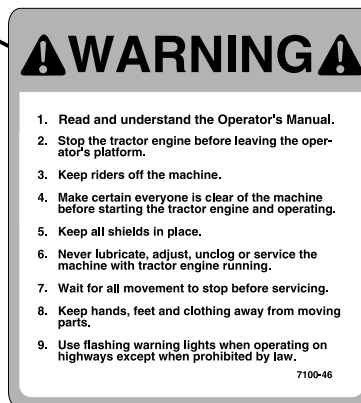

Part No. G7100-46 (Qty. 1)

SAFETY WARNING SIGNS

D013109200



Part No. G7100-302 (Qty. 1)

D010704102a

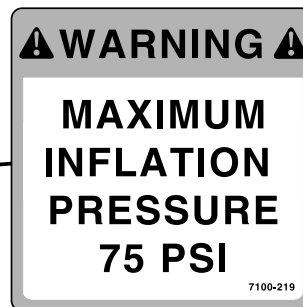

Part No. G7100-219 (Qty. 1 Per 41 x 11R22.5" transport wheel.)

D013109219



Part No. G7100-215 (Qty. 2 - Located on each side of rock shaft.)

SAFETY WARNING SIGNS

D01290906



Part No. G7100-349 (Qty. 4 - Two on each end of planter on lower marker frame - front and back. Or, two on front and two on back of top frame member.)

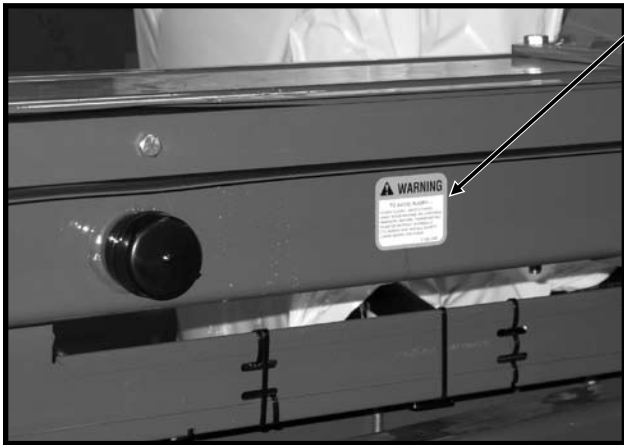

D09030905



Part No. G7100-266 (Qty. 2 - Located On Each Side of Stair)

SAFETY WARNING SIGNS

D03250837

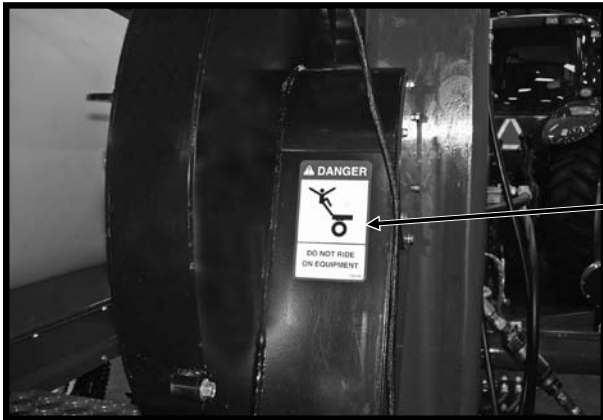

Part No. G7100-266 (Qty. 1)

(TWL279)

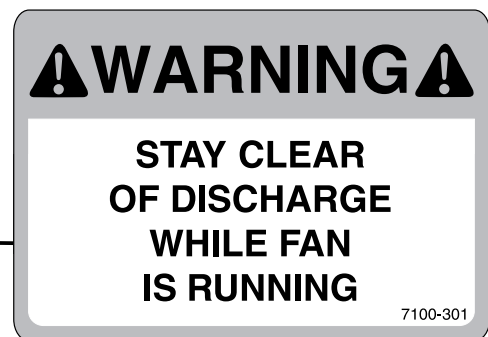
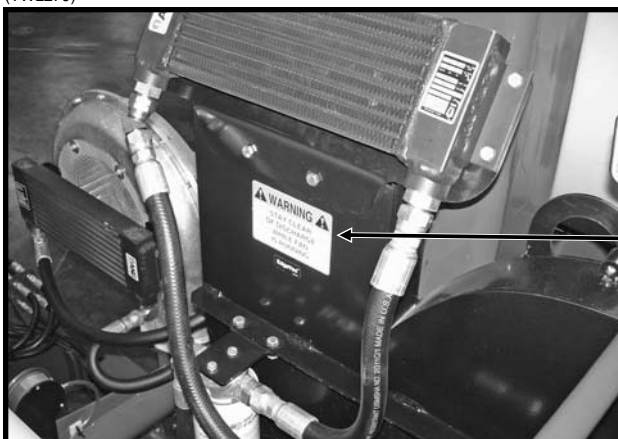

Part No. G7100-301 (Qty. 1)

D01290914

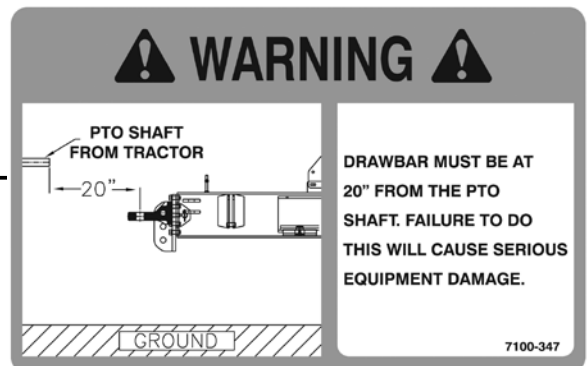

Part No. G7100-347 (Qty. 2 - Located on each side of planter pump housing.)



Part No. G7100-398 (Qty. 2 - Located on each side of planter pump housing.)

SAFETY WARNING SIGNS

(TWL174b)

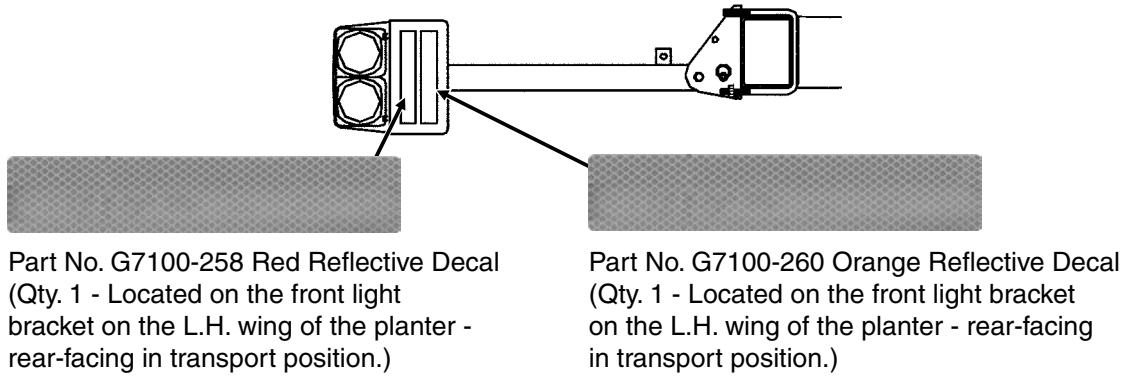

(TWL174b/RU120e)

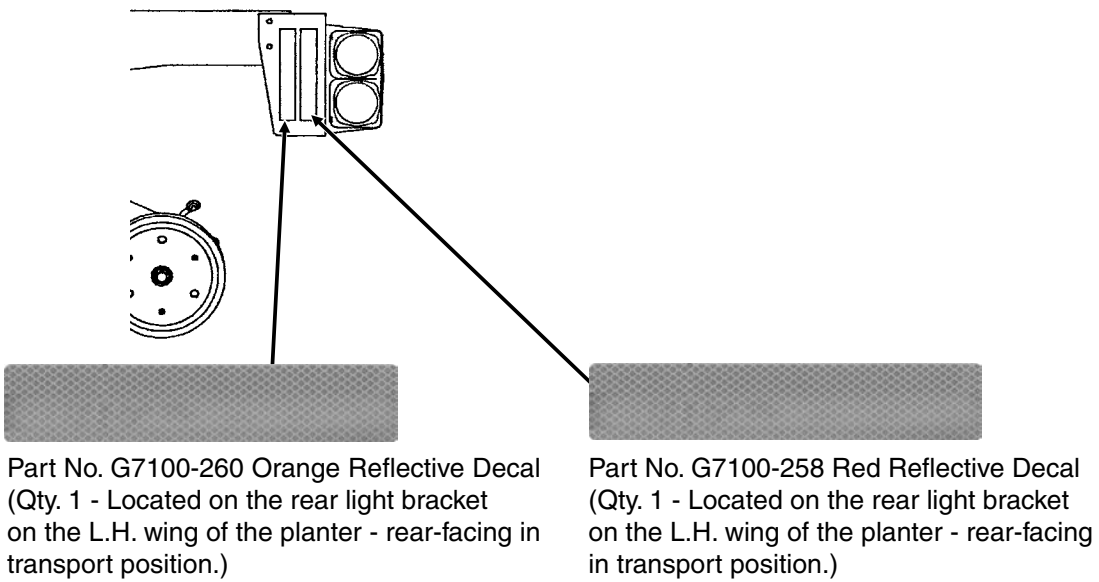

(TWL319)

Part No. G7100-259 Amber Reflective Decal (Qty. 2 - One Located On Each Side Of Hitch)

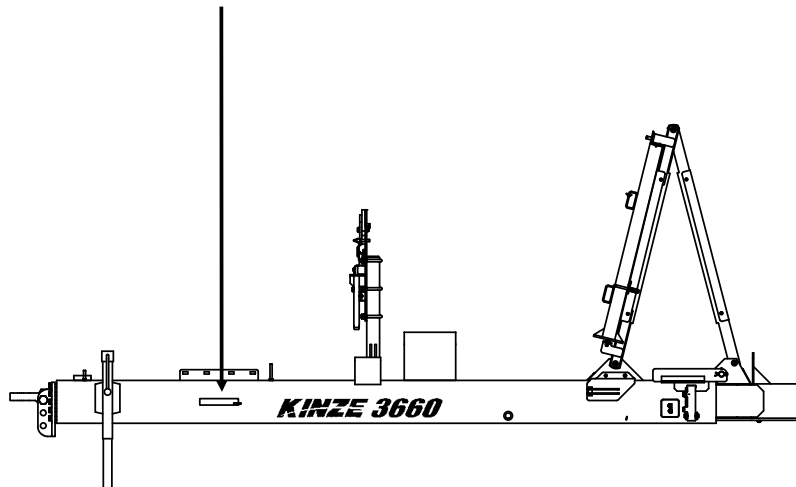

SAFETY WARNING SIGNS

(IP1058-1)

NOTE: 3660 with conventional hoppers shown. Decal Information is the same for 3660 with ASD system.

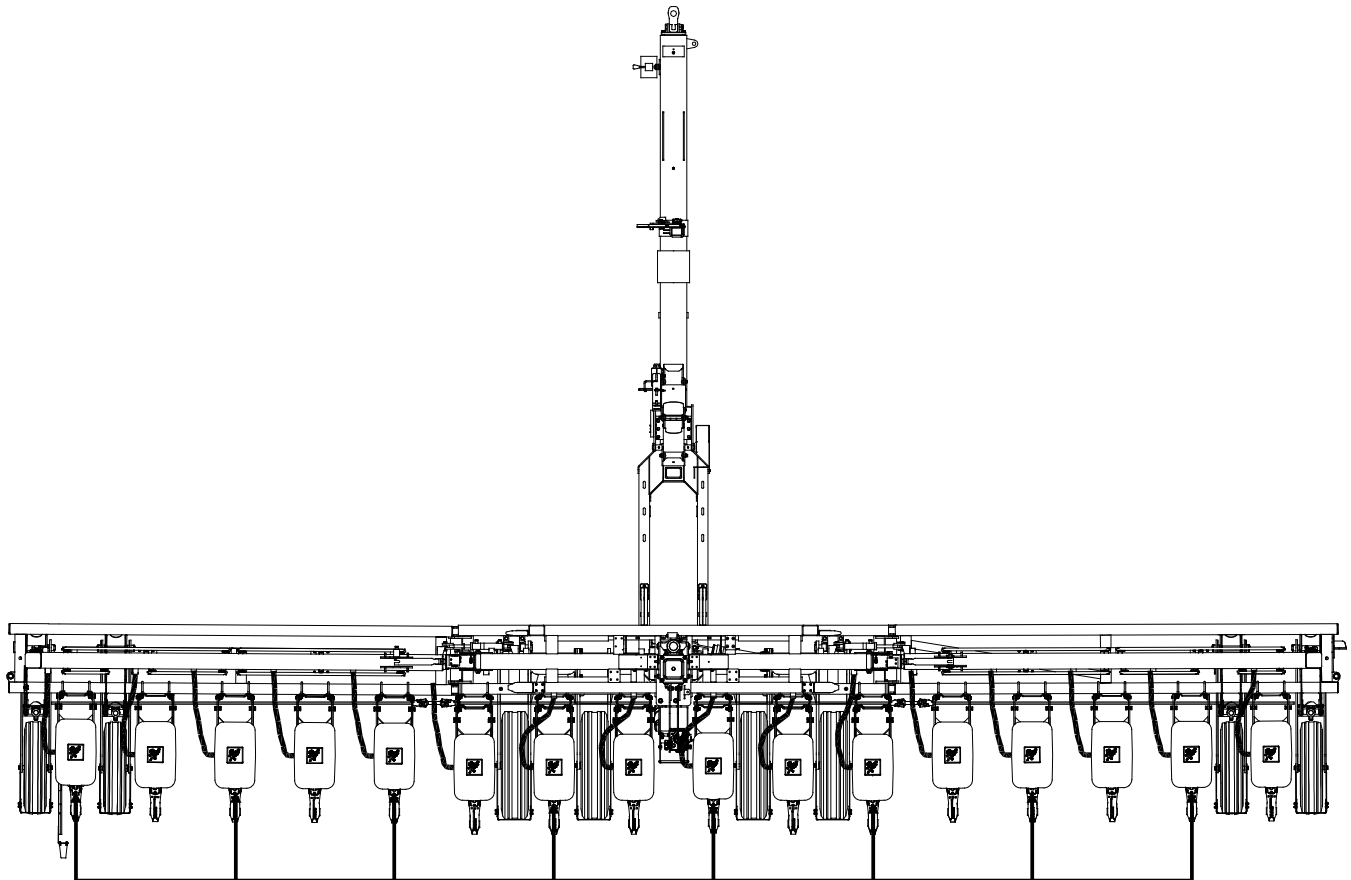

NOTE: 16 row shown. 12 row does not use outside two decals



Part No. G7100-262 Amber Reflective Decal
(Located on the hopper support on every other row unit beginning on the 1st row unit on the L.H. side of the planter.) **(Standard)**

NOTE: 6 decals used on 12 row 30", 8 decals used on 16 row 30".

D060800114

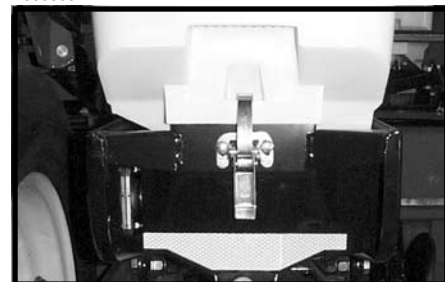

SAFETY WARNING SIGNS

(IP1058-1/IP1058-2)

NOTE: 3660 with conventional hoppers shown. Decal Information is the same for 3660 with ASD system.

NOTE: 16 row shown. 12 row similar.

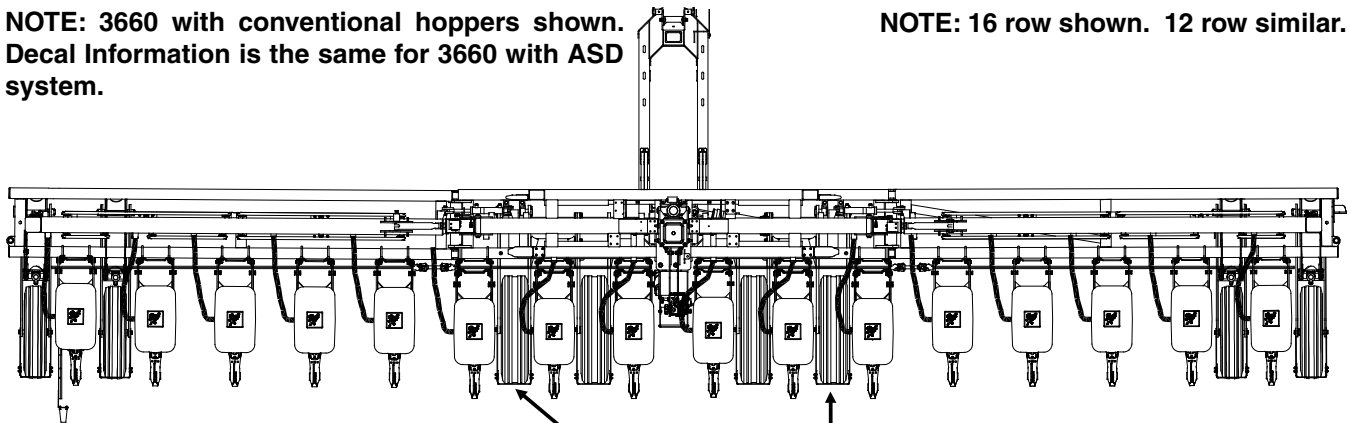

D01300902

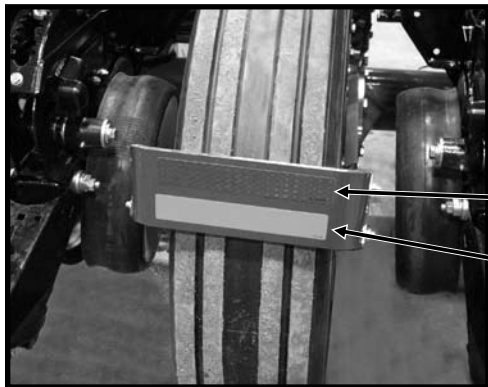

Part No. G7100-258 Red Reflective Decal
(Qty. 2 - One Per Outer Scraper - Located On Top)

Part No. G7100-260 Orange Reflective Decal
(Qty. 2 - One Per Outer Scraper - Located On Bottom)

Part No. G7100-259 Amber Reflective Decal (Located on the front side of the front toolbar - side-facing in transport position.)

NOTE: 7 used on 12 row 30" sizes. 12 row does not use outside two decals, 9 used on 16 row 30" sizes (16 row 30" shown).

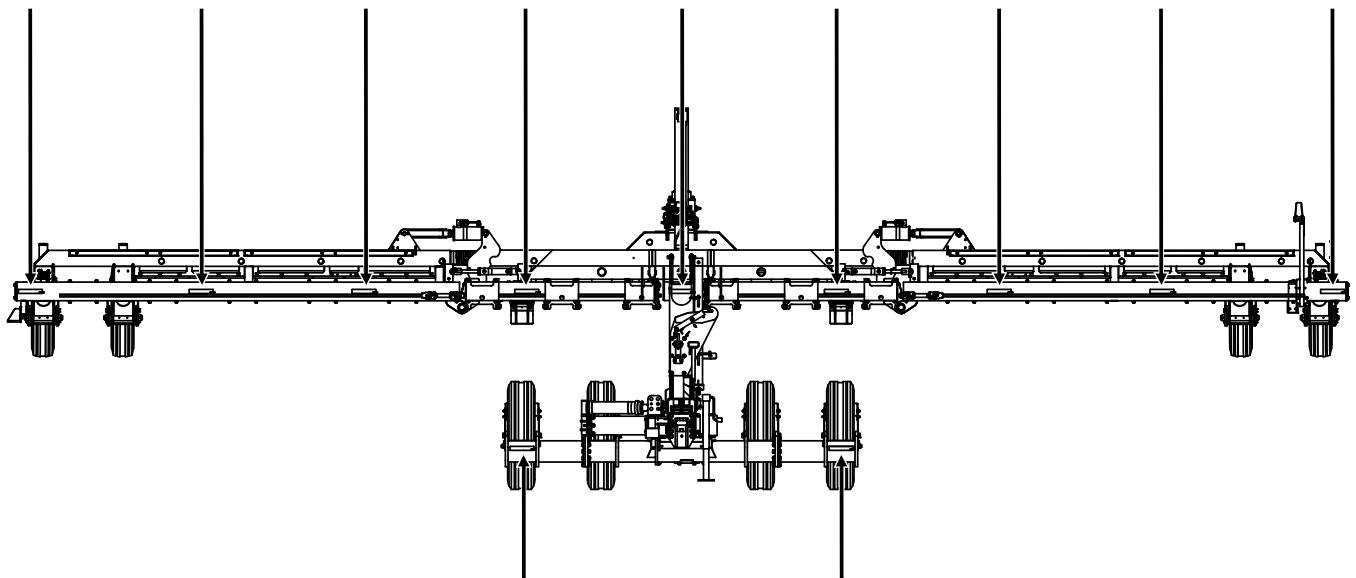

Part No. G7100-259 Amber Reflective Decal (Qty. 2 - forward-facing)

SAFETY WARNING SIGNS

D06039901

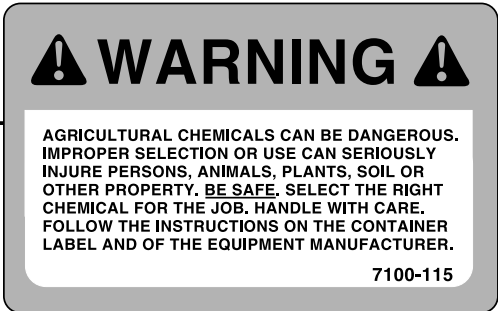

Part No. G7100-115 (1 Per Row Unit - Located On Underside Of Each Optional Granular Chemical Hopper Lid)

D021909268



Part No. G7100-249 (Qty. 1 - Located On Interplant® Push Row Unit Lift Lever)

MACHINE OPERATION

The following information is general in nature and was written to aid the operator in preparation of the tractor and planter for use, and to provide general operating procedures. The operator's experience, familiarity with the machine and the following information should combine for efficient planter operation and good working habits.

IMPORTANT: Always raise the planter out of the ground when making sharp turns or backing up.

The KINZE EdgeVac® Seed Metering System includes seed meters, seed discs and an air system consisting of a hydraulic driven vacuum fan which draws air through the manifolds and hoses and the seed meters on each row unit.

! WARNING: Never operate vacuum fan with cover removed.

ROW MARKER SAFETY LOCKUP !

! DANGER: Markers can move unexpectedly when SCV controls are operated. Being struck by a moving marker can cause serious injury or death. Keep other people away when operating row markers.

Install row marker lockups when working or transporting planter. Connect chain between marker stand and second stage of marker assembly.

D021909220

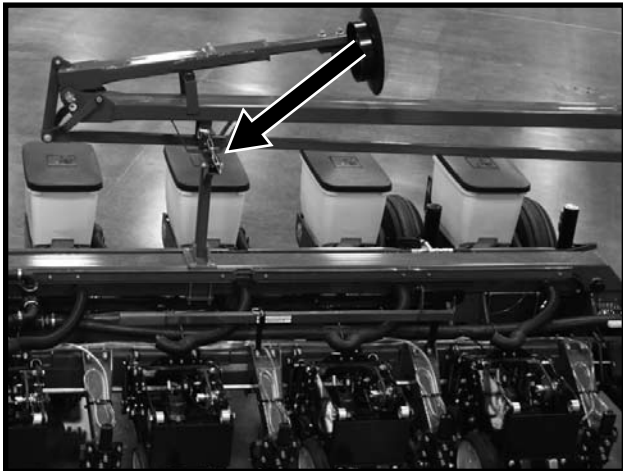

SAFETY STAND !

Never allow anyone to work around or under planter without installing safety stand. When transporting planter, always install safety stand.

Shut down tractor and remove safety stand from storage location on hose take-up. Install safety stand at center post as shown. Make sure top latch is around cylinder rod and fastened with safety pin, and that lower end is secured with detent pin.

D013109238

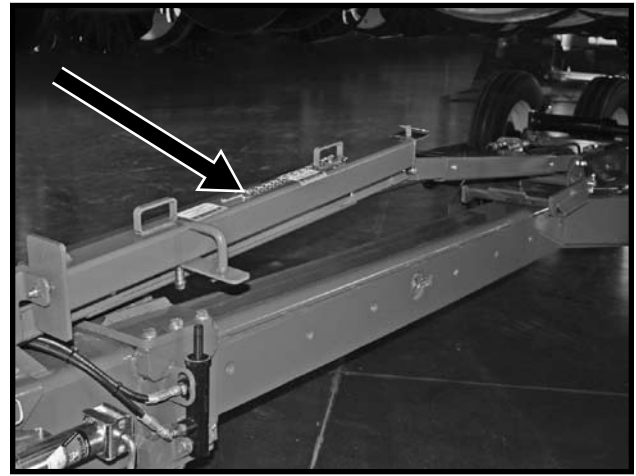

Safety stand in storage position.

D013009209

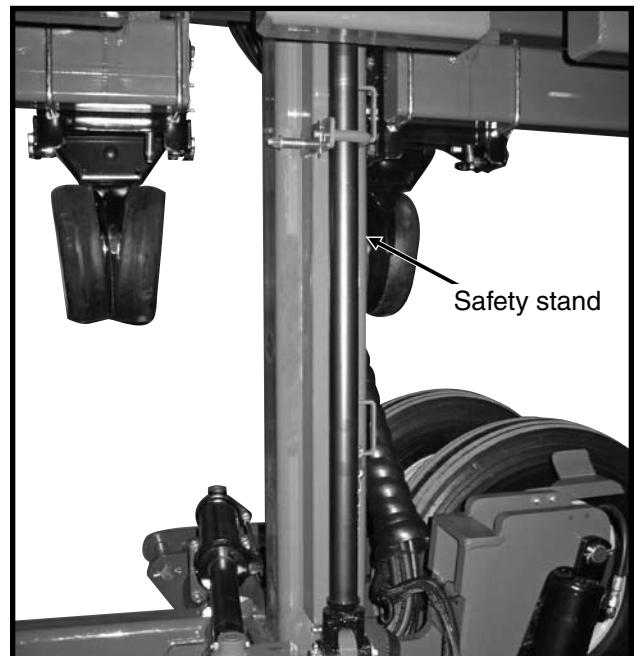

Safety stand in transport position.

MACHINE OPERATION

TONGUE SAFETY PIN

The tongue safety pin is installed to prevent the tongue cylinder from retracting if hydraulic failure occurs or a sudden stop is made during transport. When transporting planter, always install tongue safety pin.

Remove tongue safety pin from its storage location and install in hitch.

D013009214/D013009215

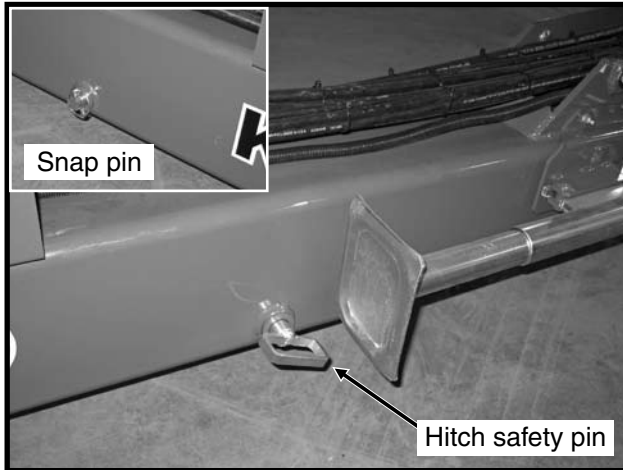

TRANSPORT LATCH LOCKING PIN

The transport latch locking pin is installed to prevent latch bar from disengaging and allowing planter to swing around. When transporting planter, always install transport latch locking pin.

Remove transport latch locking pin from its storage location and install in transport latch.

D013009204

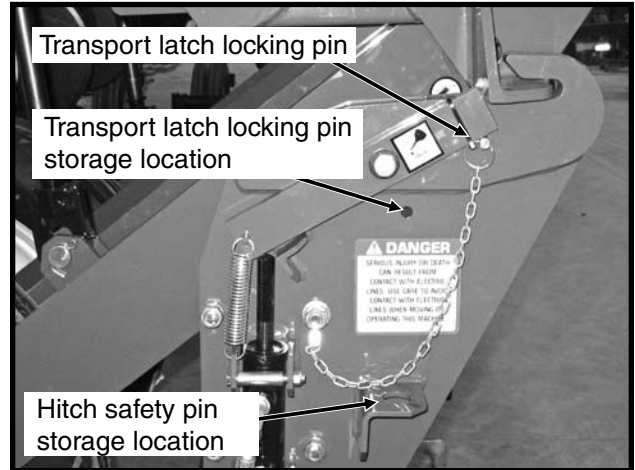

MACHINE OPERATION

INITIAL PREPARATION OF THE PLANTER

Lubricate the planter and row units per the lubrication information in this manual. Make sure all tires have been properly inflated. Check all drive chains for proper tension, alignment and lubrication.

⚠ DANGER: The outer transport wheel on the left side of the machine is shipped removed (not bolted on) to allow narrower width truck shipment. **DO NOT REMOVE THIS ASSEMBLY AFTER PLANTER IS ASSEMBLED FOR USE. DO NOT fold planter or tow planter while the outer transport wheel is removed. Tipping may occur because of narrow wheel base.**

TRACTOR REQUIREMENTS

Consult your dealer for information on horsepower requirements and tractor compatibility. Requirements will vary with planter options, tillage and terrain.

A 12 volt DC electrical system is required on all sizes.

Hydraulic Requirements

Configuration	No Optional Pumps		Tractor Mounted Pump		Planter Mounted Pump	
	SCV	gpm min.	SCV	gpm min.	SCV	gpm min.
Mechanical Meter	3	20	N/A	N/A	N/A	N/A
EdgeVac* Meter	4	40	3	25	N/A	N/A
ASD (with Mechanical Meter)	4	40	3	25	N/A	N/A
ASD (with EdgeVac)	5	55	4	40	3	25

*External case drain required for EdgeVac hydraulic circuits when no optional pumps are used.

Pump PTO Requirements: *Tractor mounted* - 1000 rpm, 1 3/8" diameter shaft. *Planter mounted* - 1000 rpm, 1 3/4" diameter shaft.

Tractor Horsepower Requirement: To effectively operate a fully optioned (ASD, Interplant®, EdgeVac®) 3660 planter, a 225 horsepower Class tractor is required.

IMPORTANT: Connect hydraulic motor case drain to a case drain return line with zero PSI on the tractor. Failure to connect to a return with zero PSI will cause damage to the hydraulic motor shaft seal. Warranty will not apply on damaged motors resulting from improper hydraulic line connection. **DO NOT** connect hydraulic motor case drain to a SCV outlet or motor return circuit connection. Contact tractor manufacturer for specific details on “zero pressure return”.

NOTE: If your tractor does not have sufficient hydraulic pump capacity, PTO pump drive and oil cooler packages are available from KINZE® through your KINZE® Dealer.

NOTE: A Flow Control Needle Valve Kit, to provide a flow control option for tractors that are not equipped with a method for finite adjustment of hydraulic flow is available from KINZE® Repair Parts through your KINZE® Dealer.

D04050604

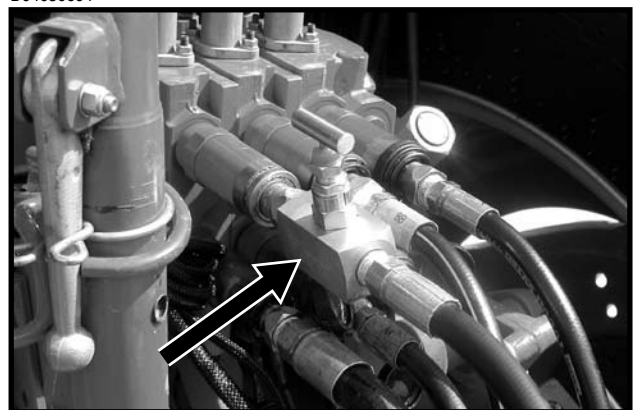

G1K426 Needle Valve Kit

MACHINE OPERATION

PTO PUMP DRIVE AND OIL COOLER OPTION - TRACTOR MOUNTED

The tractor mounted PTO pump drive and oil cooler option is designed to accommodate tractors with less than the required hydraulic output necessary to operate the hydraulic-driven vacuum fan in addition to other planter hydraulic requirements. A 1 3/8"-21 spline 1000 RPM PTO is required to operate the PTO-driven hydraulic pump. The option consists of a 1 3/8"-21 spline, 13.5 GPM 2000 PSI pump, 10 gallon capacity hydraulic reservoir, 15 GPM-rated oil cooler, spin-on 10-micron oil filter and required hydraulic valves and fittings.

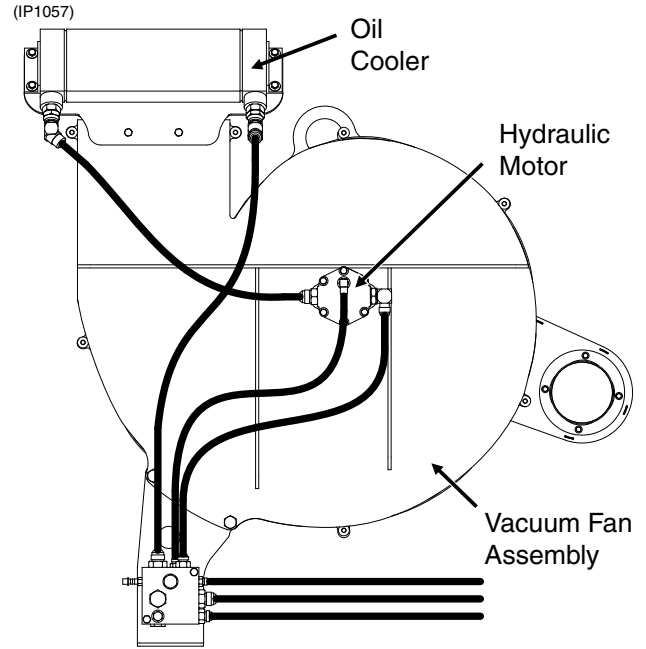

D021809200a

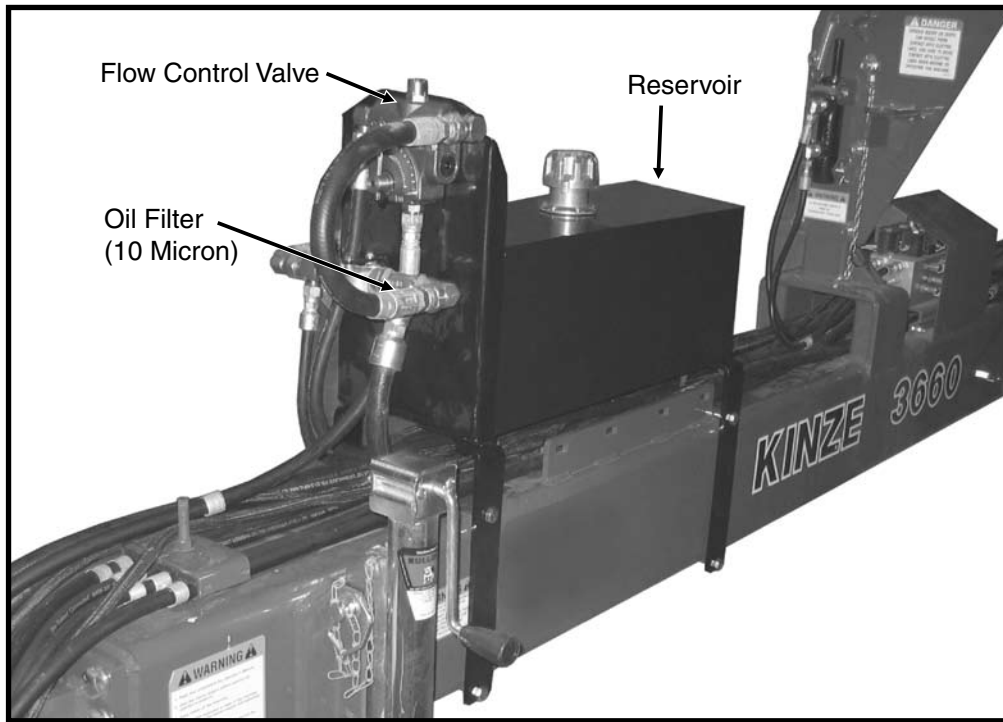

(TWL290c)

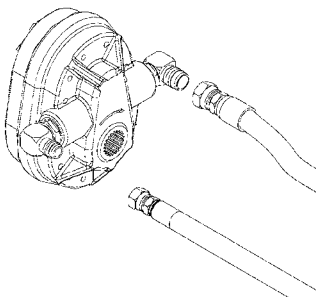

PTO-Driven Hydraulic Pump

IMPORTANT: The PTO shaft coupling should be cleaned and greased each time the pump is installed.

IMPORTANT: To extend life of shaft splines, apply a coating of high-pressure industrial coupling grease, such as Chevron® Coupling Grease, that meets AGMA CG-1 and CG-2 Standards.

(The Chevron® trademark is owned by Chevron Products Company. AGMA is the acronym for the American Gear Manufacturers Association)

MACHINE OPERATION

PUMP DRIVE AND OIL COOLER OPTION - PLANTER MOUNTED

The tractor mounted PTO pump drive with oil coolers option is designed to accommodate tractors with less than the required hydraulic output necessary to operate the hydraulically driven vacuum and pressure fans along with other planter hydraulic requirements. A 1 3/4"-20 spline 1000 rpm PTO is required to operate the planter mounted hydraulic pumps. The option consists of a PTO driveshaft, 13.5 gpm/2000 psi two-section pump, 10 gallon hydraulic oil reservoir, two oil coolers, two spin-on 10-micron oil filters, and required valves and fittings.

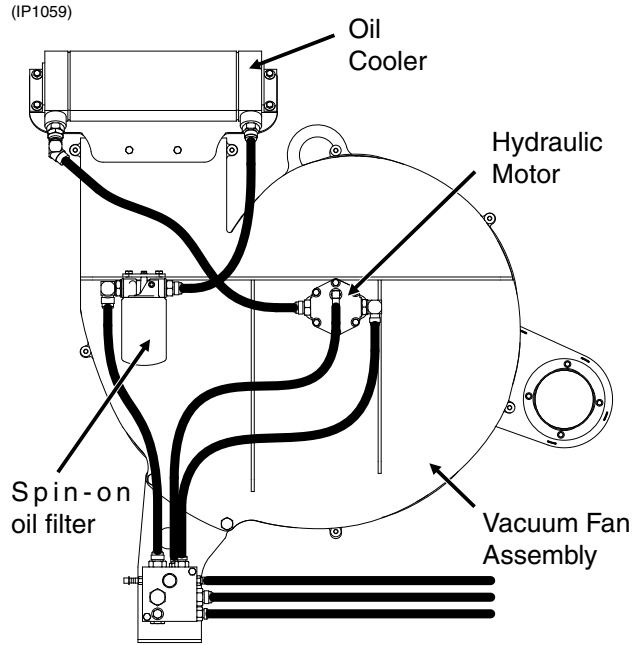

Flow control valve - ASD fan (opposite side)
Flow control valve - EdgeVac® fan (shown)

D013109272

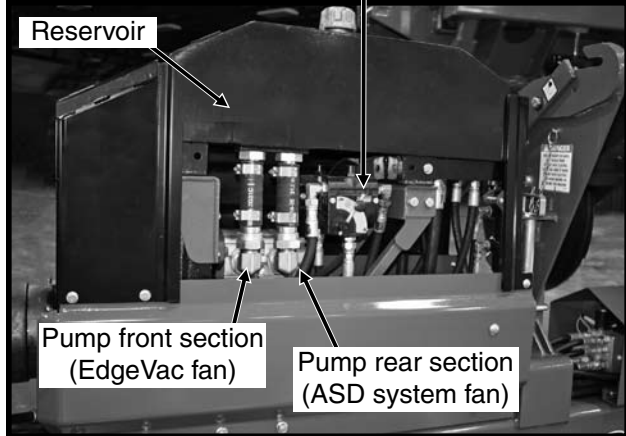

D032609200

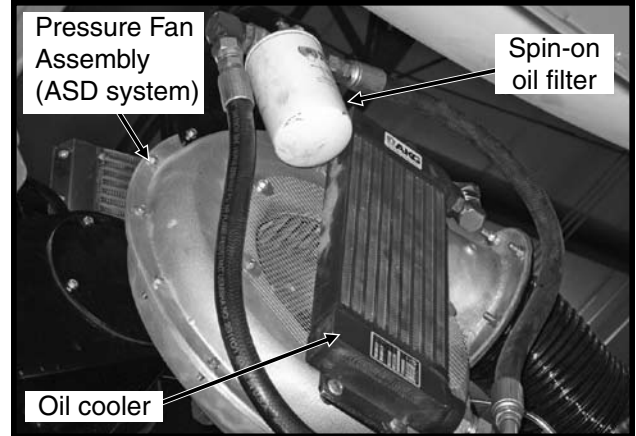

IMPORTANT: The PTO shaft coupling should be cleaned and greased each time the driveshaft is installed.

IMPORTANT: To extend life of shaft splines, apply a coating of high-pressure industrial coupling grease, such as Chevron® Coupling Grease, that meets AGMA CG-1 and CG-2 Standards.

(The Chevron® trademark is owned by Chevron Products Company. AGMA is the acronym for the American Gear Manufacturers Association)

MACHINE OPERATION

TRACTOR PREPARATION AND HOOKUP

D013109200



NOTE: A 2-Point Hitch Option, which converts the planter from drawn to semi-mounted, is available for use with Category 3N or 3 three-point hitch designs. The safety chain is not applicable with the 2-point hitch. The 2-point hitch can not be used with planter mounted PTO pump.

D013109200

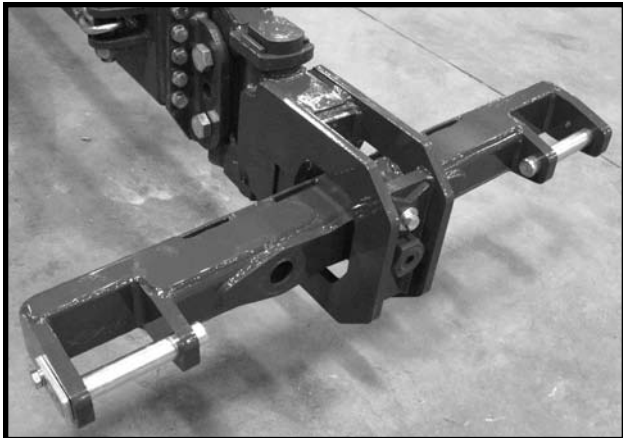

1. Adjust tractor drawbar to 13-17 inches above the ground. Adjust the drawbar so the hitch pin hole is directly below the center line of the PTO shaft. Make sure the drawbar is in a stationary position.
2. Install control console on tractor in a convenient location within reach of the operator and close to the hydraulic controls. Mount control console securely and route power cord to the power source.

The control console operates on 12 volt DC only. If two 12 volt batteries are connected in series, ALWAYS make power connection on the battery which is grounded to the tractor chassis.

If two 6 volt batteries are connected in series, make sure the power connection provides 12 volt DC across the positive terminal on one battery and negative terminal of the second battery.

3. Back tractor to planter and connect with 1 1/2" diameter hitch pin. If the tractor is not equipped with a hitch pin locking device, make sure hitch pin is secured with a locking pin or cotter pin.
4. The auxiliary attaching system (transport safety chain) provided with your planter should be used to ensure the connection is retained between the planter and tractor in the event of a hitch pin/drawbar failure. The safety chain is to be attached using an unused clevis mounting hole on the planter hitch. The mounting hardware should be torqued to 840 ft. lbs. Connect the hook end of the chain securely around a tractor frame member.

MACHINE OPERATION

- Connect hydraulic hoses to tractor ports in a sequence which is both familiar and comfortable to the operator.

The planter operation hydraulic hoses are color coded as follows:

Color and Label	Machine Function	Hose Size	Hose Function
Red AA	Field Lift	1/2"	Pressure
Red BB		1/2"	Return
Blue AA	Planter Fold & Row Marker	3/8"	Return
Blue BB		3/8"	Pressure
Black RR	Seed Rate Hydraulic Drive (EdgeVac®)	3/4"	Return
Black PP		1/2"	Pressure
Black RR	Seed Rate Hydraulic Drive (Mechanical)	1/2"	Return
Black PP		3/8"	Pressure
Green RR	EdgeVac® Vacuum Fan	3/4"	Return
Green PP		1/2"	Pressure
Green CD		1/4"	Case Drain
Yellow RR	ASD System Pressure Fan	3/4"	Return
Yellow PP		1/2"	Pressure

NOTE: EdgeVac® and the Air Seed Delivery system are options that can receive their hydraulic requirements from a tractor with an adequate hydraulic system, or from an optional tractor or planter mounted hydraulic pump. Refer back to "TRACTOR REQUIREMENTS" for system requirements.

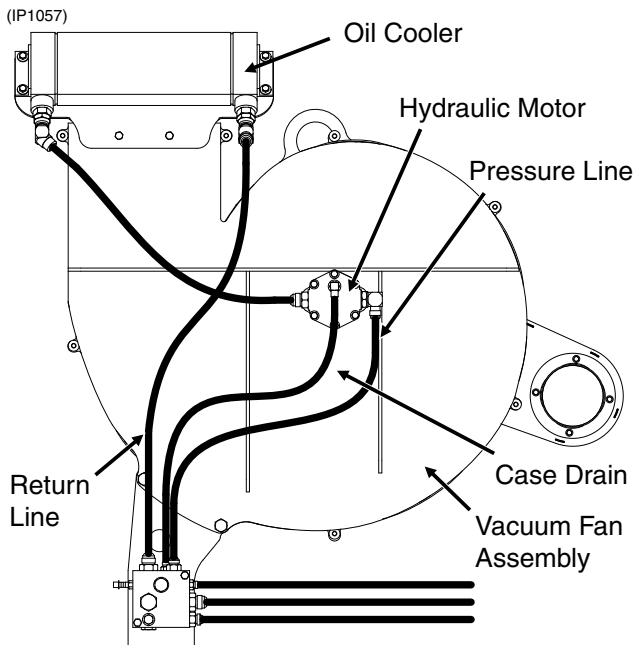

Return to Table of Contents



DANGER: Pressurized hydraulic fluid can penetrate body tissue and result in serious infection, injury, or death. Before applying pressure to the hydraulic system, make sure all connections are tight and that hoses and fittings have not been damaged. Leaks can be invisible. Keep away from suspected leaks. Relieve pressure in the hydraulic system before searching for leaks, disconnecting hoses, or performing any other work on the system. Fluid injected under the skin must be IMMEDIATELY removed by a surgeon familiar with this type of injury.

IMPORTANT: Always wipe hose ends to remove any dirt before connecting couplers to tractor ports.

- Connect cable on planter to control console cable on tractor. Connect ASAE Standards 7 terminal connector for safety/warning lights on planter to ASAE Standards receptacle on tractor. If your tractor is not equipped with an ASAE Standards receptacle, check with your tractor manufacturer for availability. Check to be sure safety/warning lights on planter are working in conjunction with warning lights on tractor.
- Raise jack and remount horizontally on storage bracket.
- Lower planter to the planting position and check to be sure the hitch is level. If hitch slopes up or down, disconnect planter and adjust hitch clevis up or down as necessary.

MACHINE OPERATION

LEVELING THE PLANTER

For proper performance of the planter and row units, it is important that the planter frame and row unit parallel arms operate approximately level. The toolbar should operate at a 20" – 22" height, measured from the planting surface to the bottom of the toolbar.

D013109200



Four holes in the hitch bracket allow the clevis to be raised or lowered. In addition, the clevis may be turned over for a finer adjustment between mounting holes. When installing the clevis mounting bolt, make sure the lock nut is tightened to 840 ft. lbs.

D013109200

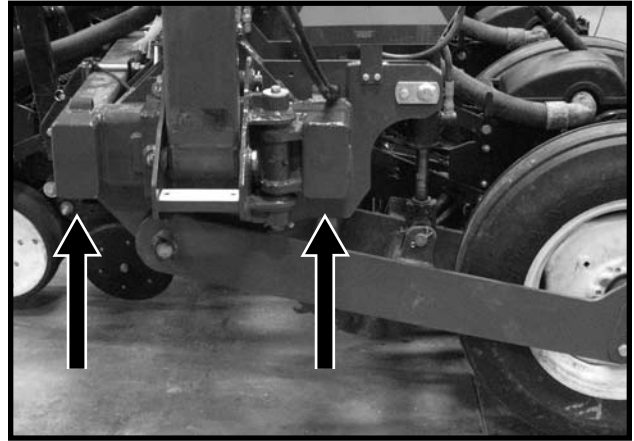

With the planter lowered to operating height, check to be sure the frame is level fore and aft. Recheck once planter is in the field.

It is important for the planter to operate level laterally. Tire pressure must be maintained at pressures specified. See "Tire Pressure".

Field and actual planting conditions will dictate which of the transport wheel settings to use to ensure row unit parallel arms are approximately parallel with the planting surface. It may also be necessary to lower the field wheels to ensure level lateral toolbar operation if the transport wheels are set in one of the two lower sets of holes.

MACHINE OPERATION

(RU113h)

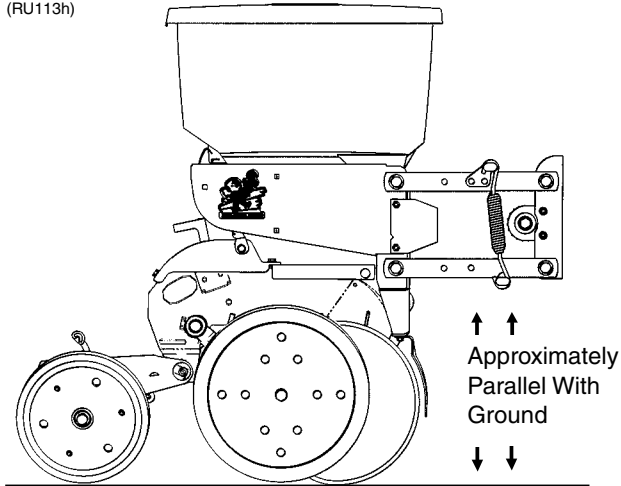

D032309200a

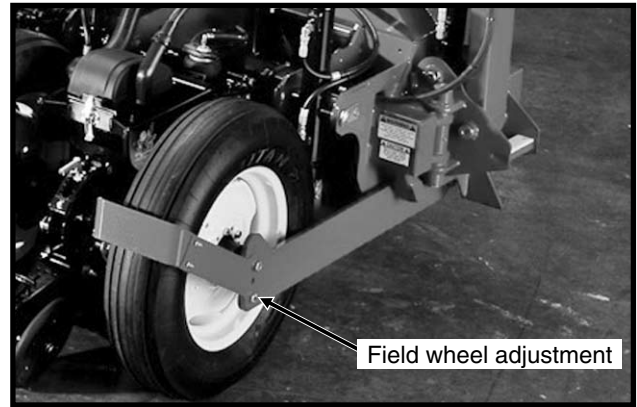

FIELD WHEEL

When the planter has been fully loaded with seed, granular chemicals, fertilizer, etc.; a field check should be made to be sure the wings are level with the center frame. If the wings are not level with the center frame, the drive wheels and/or transport wheels can be raised or lowered in the wheel arms to increase or decrease planter toolbar height. Hitch height should be raised accordingly to ensure level operation.

NOTE: As the lift cylinders are (port type) rephasing type, it is necessary for the cylinders to fully retract in order to rephase. Cylinder stops can not be used.

D013109218

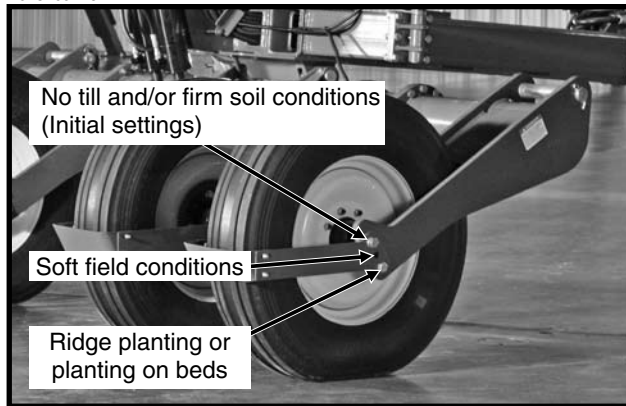

TRANSPORT WHEEL

CAUTION: When using top hole setting, check clearance between tires and drill shaft U-joint prior to operation.

NOTE: On planters equipped with push row units and no till coulters, the uplift from the down force springs or air springs in the pneumatic down pressure system may cause the wings to rise slightly in planting position. The problem may be compounded if static pressure is trapped in the planter's hydraulic lift system which can cause the wing cylinders to extend slightly. Operating the tractor's hydraulic system in the float position or moving the tractor's hydraulic lever to the float position briefly, to relieve the pressure, will help to maintain the proper toolbar height.

MACHINE OPERATION

TIRE PRESSURE

D01290926

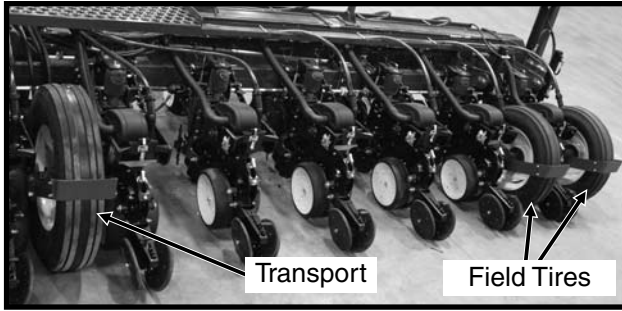

Tire pressure should be checked regularly and maintained as follows:

255-70R 22.5" Transport (Center Section)	75 PSI
7.50" x 20" Field Tires (Wings)	40 PSI
7.60" x 15" Ground Drive (Liquid Fertilizer Piston Pump)	40 PSI

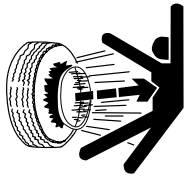

! DANGER: Rim and tire servicing can be dangerous. Explosive separation of tire and rim parts can cause serious injury or death.

Do not attempt to mount a tire unless you have the proper equipment and experience to perform the job. This should only be done by persons properly trained and equipped to do the job.

Always maintain the correct tire pressures. Do not inflate the tires above the recommended pressures.

When inflating tires, use a clip-on air chuck and extension hose long enough to allow you to stand to one side and NOT in front of or over the tire assembly. Use a safety cage to enclose the tire and rim assembly when inflating.

Inspect tires and wheels daily. Do not operate with low pressure, cuts, bubbles, damaged rims or missing lug bolts and nuts.

RIDGE PLANTING

When ridge planting, the drive wheels and transport wheels can be lowered 2" or 4" to the lower mounting holes in the wheel arms to increase the planter toolbar height. The contact drive tire must also be lowered to the lower set of holes in the wheel module and the down pressure springs hooked on the lower rod. Hitch height should be raised accordingly to ensure level operation.

Wheel Shown Mounted In Standard Location - Lower 2" Or 4" To Lower Mounting Holes When Ridge Planting

D013109218



NOTE: The toolbar should operate at a 20"-22" height measured from the bottom of the toolbar to the planting surface.

MACHINE OPERATION

CONTROL CONSOLE OPERATION

D09110902

WARNING: Never work under planter while in raised position without installing safety lockup devices.

WARNING: Make sure all hydraulic hoses are properly connected before operating planter. Never connect or disconnect hydraulic hoses without first stopping tractor engine and neutralizing pressure within the hydraulic system.

The tractor's hydraulic system and planter control console are used to raise and lower planter, rotate frame, extend and retract tongue, lock and release wings, and operate row markers.

DANGER: Extended row markers can make contact with power lines. Electrocutation can cause serious injury or death. Make sure area is clear of power lines before operating row markers.

NOTE: The control console face is backlit and equipped with a power switch on the back side. Turn off console when not in use.

NOTE: The hydraulic weight transfer toolbar operates whenever planter is in motion and hydraulic seed rate drive is operating.

Model 3660 planters operate using three to five dual remote (SCV) hydraulic outlets:

1. Raise and lower planter during field operation with axle rockshaft (field lift).
2. In conjunction with control console switches, controls row markers, center post, wing locks, rotation, and tongue extension.
3. Hydraulic seed rate drive.
4. EdgeVac blower drive (optional).
5. Air Seed Delivery blower drive (optional).

WARNING: Markers can move unexpectedly when SCV controls are operated. Being struck by a moving marker can cause serious injury or death. Keep marker switch in OFF position when not in use.



Switches on control console operate as follows:

- Marker switch is an ON / OFF / ON type used to select right or left hand marker operation; it is disabled when a planter fold function is selected. An indicator light is illuminated when this switch is in an ON position.
- Raise/wing lock and rotate/tongue switches are MOMENTARY ON / OFF / MOMENTARY ON type used to select a planter fold function. They must be held in position while operating the tractor SCV control for the desired function to operate.
- Down pressure switch is also a MOMENTARY ON / OFF / MOMENTARY ON type used to increase or decrease row unit down pressure.
- Work light switch is on ON / OFF type used to control optional planter mounted work lights.
- Point row switches are not used on the Model 3660 planter. This function is controlled by the KINZE Vision® or Cobalt™ planter controller.

MACHINE OPERATION

TRANSPORT TO FIELD SEQUENCE

NOTE: Planter must be attached to tractor and unfolded in an open, level area.

D032309217



Summarized Transport To Field Sequence

1. Remove hitch safety pin and transport latch locking pin.
2. Remove safety stand.
3. Rotate planter to field position.
4. Lower planter on center post.
5. Release wing locks.
6. Raise planter using field lift.
7. Retract tongue.
8. Remove row marker lockups.

NOTE: Refer to information that follows for detailed instructions.

NOTE: At the tractor hydraulic outlets, red coded hoses operate field lift function, and blue coded hoses operate raise, wing lock, rotate and tongue functions.

1. Starting with planter in transport position and tractor shut down, remove hitch safety pin and transport latch locking pin and place both in their storage locations.

D013009214/D013009215

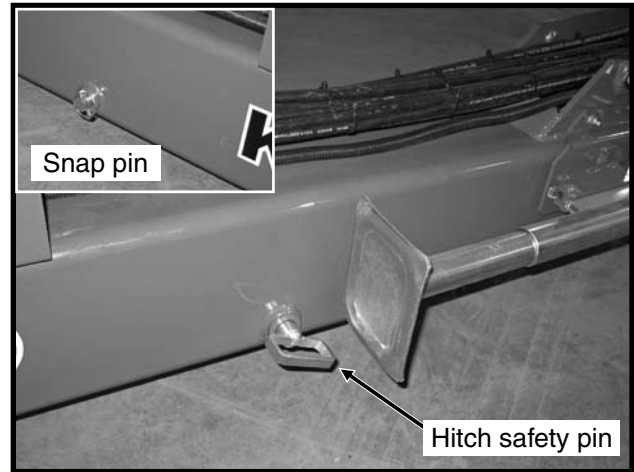

D013009204

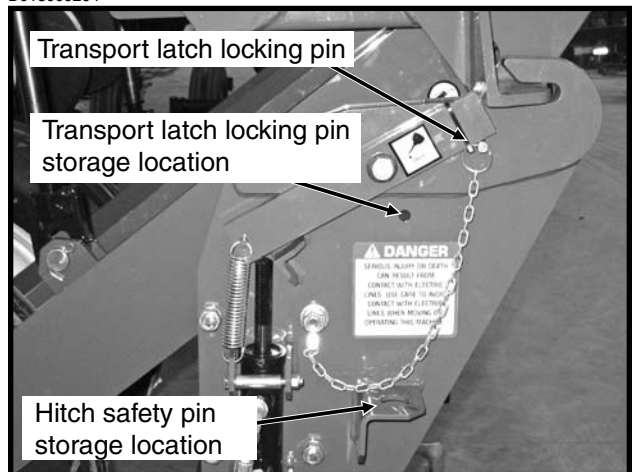

MACHINE OPERATION

2. Remove safety stand from center lift cylinder and place in storage location on hose take-up.

D013009209

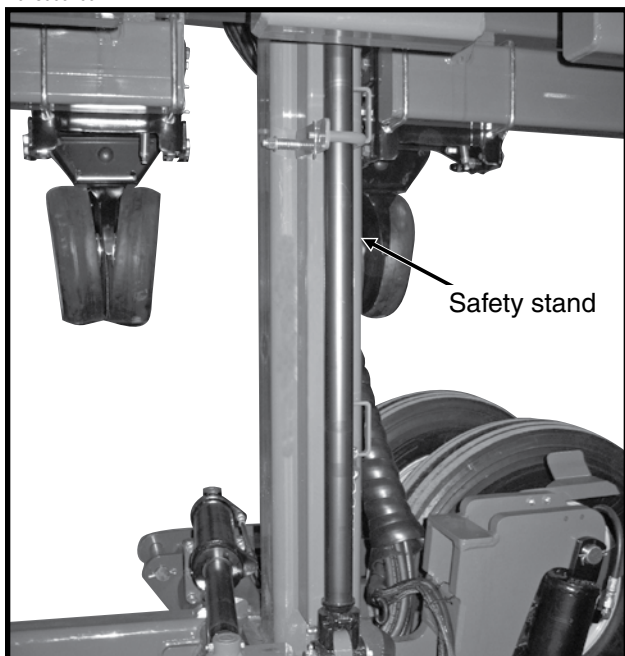

D013109238

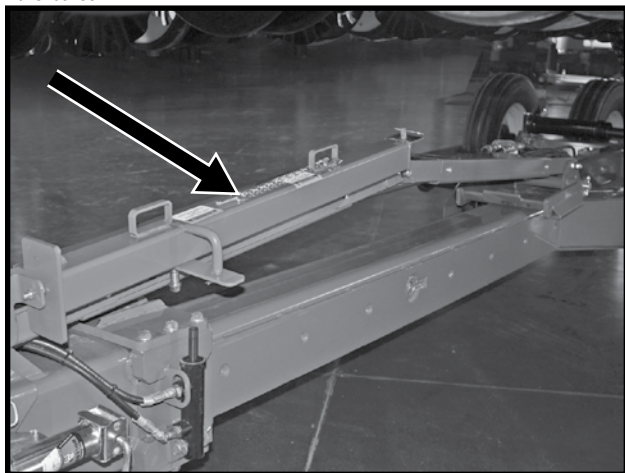

3. Start up tractor. Hold rotate/tongue switch to ROTATE and operate hydraulic control to rotate planter to field position. Transport latch will automatically release.

D09110902



D032309210



IMPORTANT: Center post lift is used only for folding or unfolding planter. Raising and lowering planter during field operation is performed using field lift (axle rockshaft).

4. Hold raise/wing lock switch to RAISE and operate hydraulic control to fully lower planter on center post.

D032309201



MACHINE OPERATION

5. Hold raise/wing lock switch to WING LOCK and operate hydraulic control to release wing locks.

D032509201



6. Operate hydraulic control to raise planter using field lift.

D032309206



7. Hold rotate/tongue switch to TONGUE and operate hydraulic control to fully retract tongue. Tongue latch will automatically engage.

D032309203



8. Remove row marker lockups.

D021909220

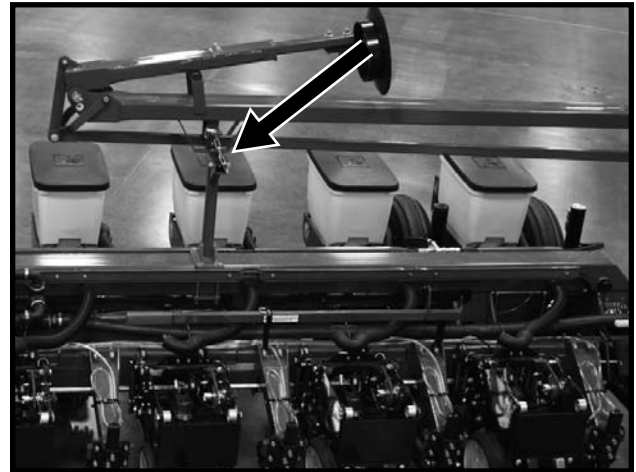

FIELD LIFT OPERATION

During field operation, raising and lowering planter is performed using field lift (axle rockshaft).

NOTE: The field lift cylinders are rephasing cylinders and it is necessary to fully lower planter to rephase them. Cylinder stops can not be used.

D032309203



D032509201



MACHINE OPERATION

FIELD TO TRANSPORT SEQUENCE

NOTE: Planter must be attached to tractor and folded in an open, level area.

Summarized Field To Transport Sequence

1. Install row marker lockups.
2. Raise planter using field lift.
3. Extend tongue.
4. Engage wing locks.
5. Lower planter using field lift.
6. Raise planter on center post.
7. Rotate planter to transport position.
8. Install safety stand.
9. Install hitch safety pin and transport latch locking pin.

NOTE: Refer to information that follows for detailed instructions.

NOTE: At the tractor hydraulic outlets, red coded hoses operate field lift function, and blue coded hoses operate raise, wing lock, rotate and tongue functions.

1. Install row marker lockups.

D021909220

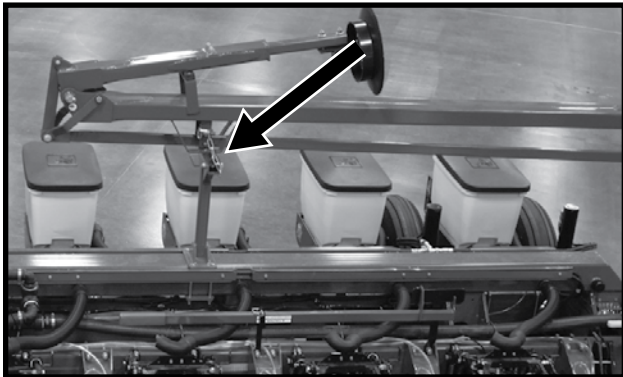

2. Start up tractor; operate hydraulic control to raise planter using field lift.

D032309203

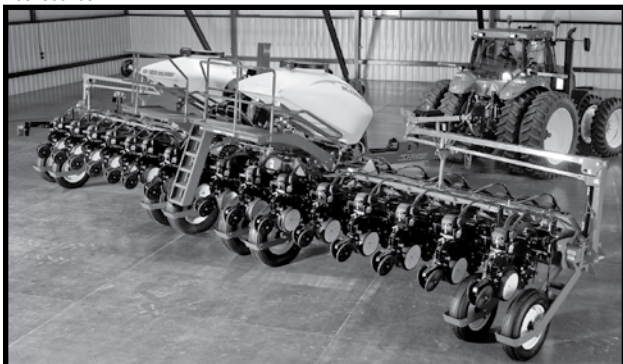

Return to Table of Contents

3. Hold rotate/tongue switch to TONGUE and operate hydraulic control to fully extend tongue. Tongue latch will automatically disengage.

D09110902



D032309206

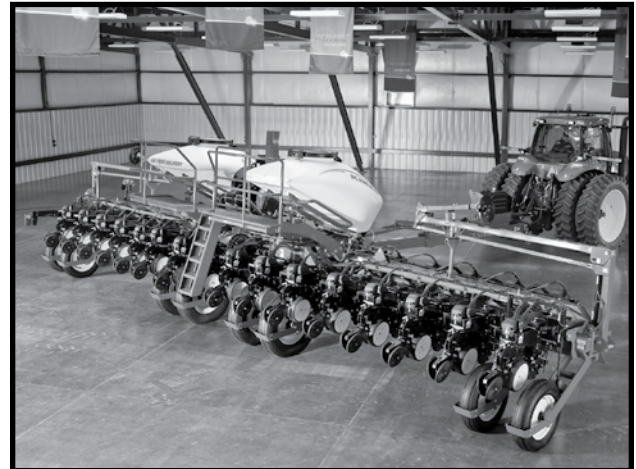

4. Hold raise/wing lock switch to WING LOCK and operate hydraulic control to engage wing locks.

D032309206

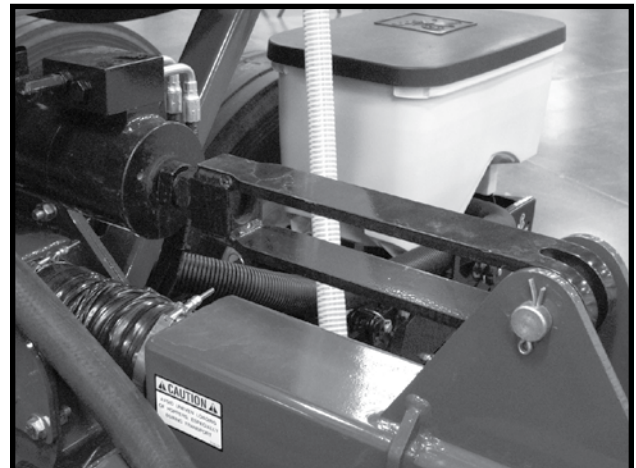

MACHINE OPERATION

5. Operate hydraulic control to lower planter using field lift.

D032309201



6. Hold raise/wing lock switch to RAISE and operate hydraulic control to fully raise planter on center post.

D032309210



7. Hold rotate/tongue switch to ROTATE and operate hydraulic control to rotate planter to transport position. Transport latch will automatically engage.

D032309217



8. Shut down tractor and remove safety stand from storage location on hose take-up. Install safety stand at center post as shown. Make sure top latch is around cylinder rod and fastened with safety pin, and that lower end is secured with detent pin.

D013109238

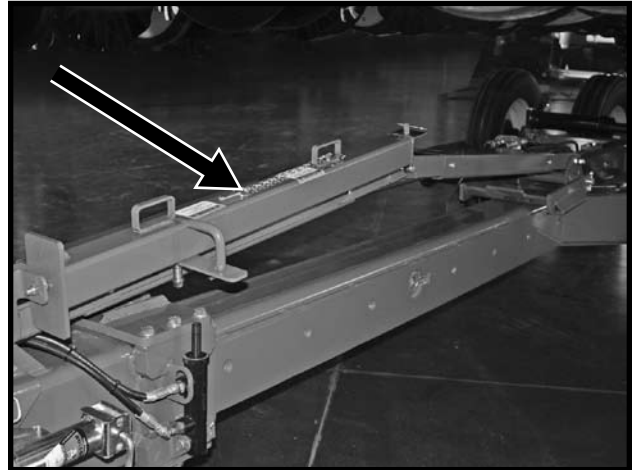

D013009209

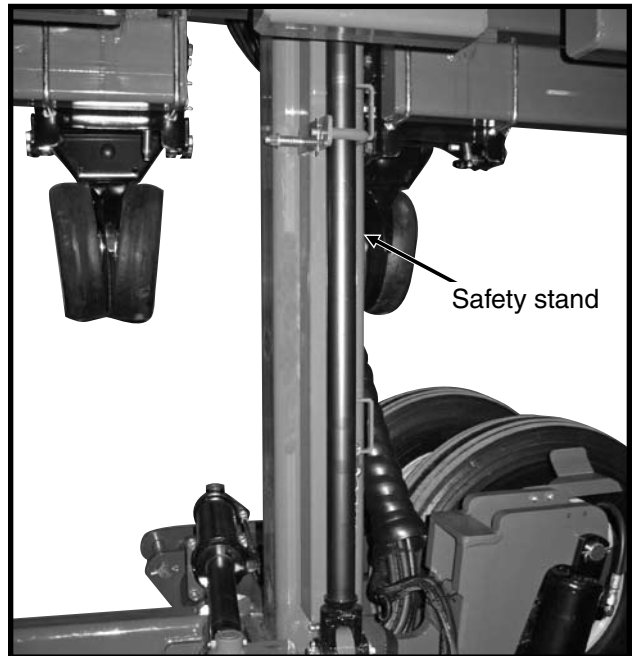

MACHINE OPERATION

- 9. Remove hitch safety pin and transport latch locking pin from their storage locations and install in hitch and transport latch.

D013009214/D013009215

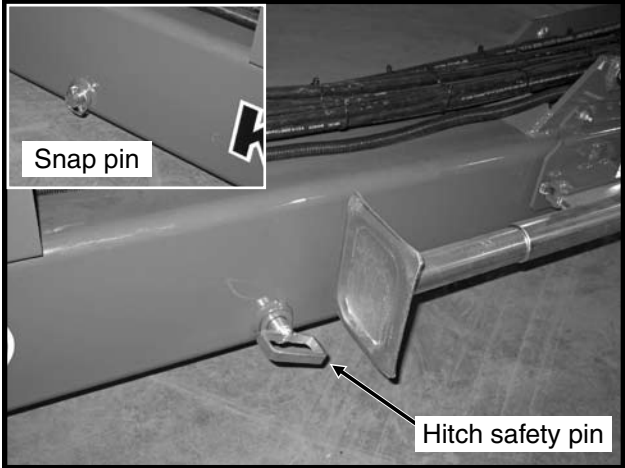

D013009204

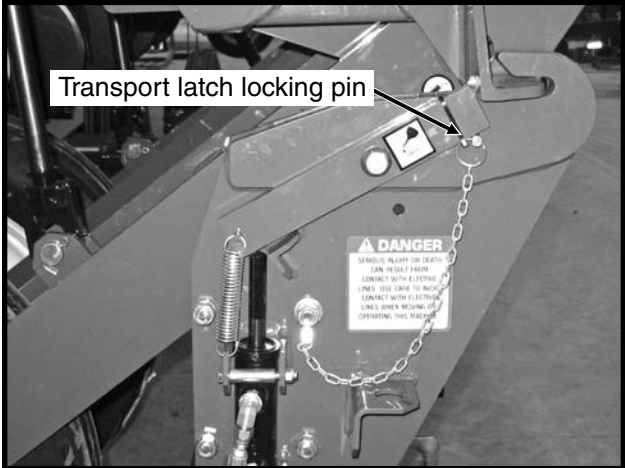

MACHINE OPERATION

D030909218

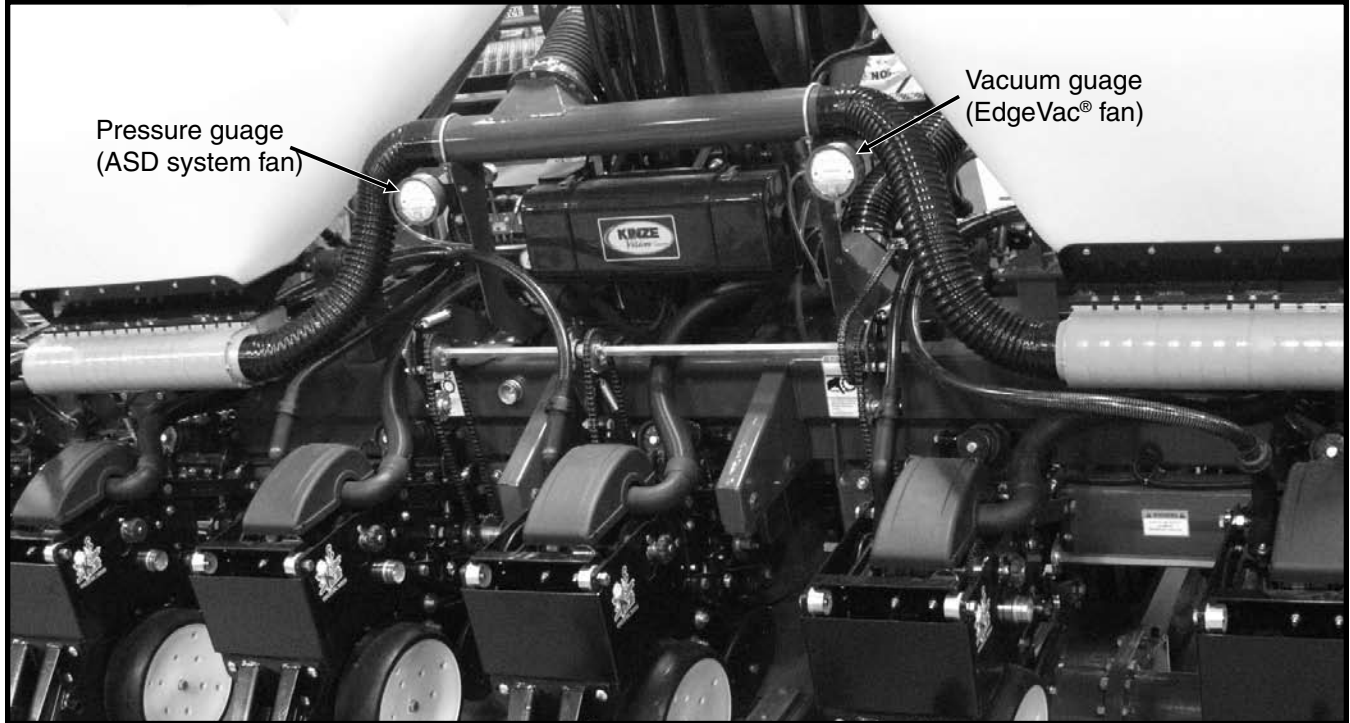

DIGITAL VACUUM GAUGE

Digital vacuum readout is incorporated into the KINZE Vision® and Cobalt™ displays. Refer to their operation manuals for instructions.

ANALOG VACUUM AND PRESSURE GAUGES

The analog vacuum and pressure gauges connect directly to their manifolds.

The only adjustment to the gauges is to “zero” the needle with no vacuum or pressure present.

MACHINE OPERATION

AIR SEED DELIVERY SYSTEM

IMPORTANT: When filling the ASD hoppers, make sure seed is clean and free of debris. Foreign materials can cause the system to plug.

D031809232

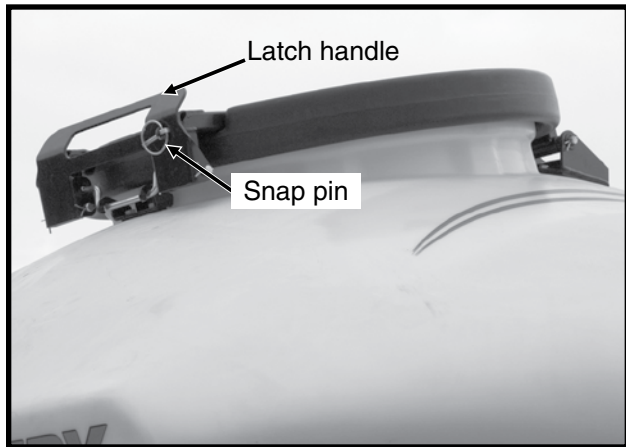

Prior to 2010 production

D09030902

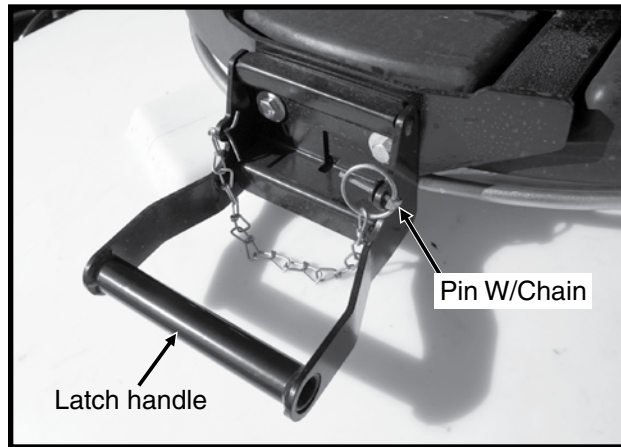

2010 production and on

Fill hoppers with seed, latch lids, and secure with pin. The air seed delivery system itself does not need any additional lubricant other than what is needed for the seed meters. Refer to "Seed Meter Operation" for correct amounts and placement.

IMPORTANT: Do not turn on system with tractor engine at full speed.

Start air seed delivery system with tractor engine at idle. Increase engine speed to full and set initial system pressure using flow control valve. Allow system to warm up and adjust pressure if necessary.

Recommended pressures:

- Corn – 12 inches of water
- Soybeans – 10 inches of water
- Actual pressure needed is affected by seed size, shape, and coating.

D031809232



CAUTION: Seed in delivery tubes is moving at high velocity. Seed flying out of disconnected delivery tube can cause personal injury. Do not disconnect delivery tubes when system is operating.

MACHINE OPERATION

ASD ENTRAINER ACCESS

To gain access to the entrainer when the hopper is full, perform the following:

1. Shut down air seed delivery system.
2. Loosen wing nut and turn retainer holding shutoff door in its storage location.
3. Remove rubber plug closest to area in entrainer needing attention.
4. Insert shutoff door into open slot and push into entrainer at a slight upward angle.
5. When work is complete, remove shutoff door, return door to its storage location, and plug open slot.

D031809232

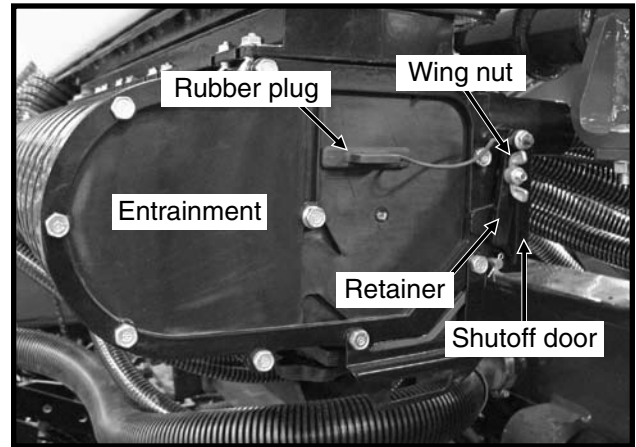

PROBLEM	POSSIBLE CAUSE	SOLUTION
Seed does not travel through delivery tubes.	System pressure set too low.	Increase system pressure.
Seed stops flowing to row unit during planting.	Seed surging.	Shut down air seed delivery system and restart system from idle; seed should start flowing.
	Debris in system.	Insert shutoff door, open cleanout door. remove plug.
Seed does not move from entrainer at startup following exposure to water.	Seed has swelled in entrainer.	Insert shutoff door, open cleanout door. remove swelled seed.

MACHINE OPERATION

ASD TANKS - CLEAN OUT

To clean out ASD tanks, perform the following:

1. Remove ASD tank cleanout chute from storage location beneath catwalk.
2. Position tube of chute between Interplant row units (if applicable) and attach hooks on each end of entrainment assembly.
3. Open trap doors of entrainment assembly and allow tank to empty.
4. After tank is empty, close all trap doors and return clean out chute to storage location.

16 Row Shown

D033009202

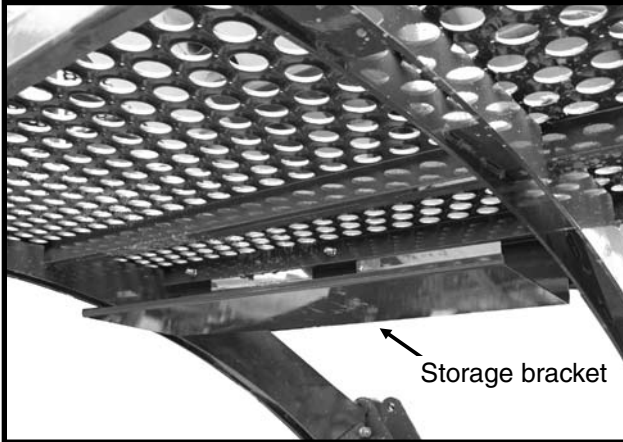

D032509218

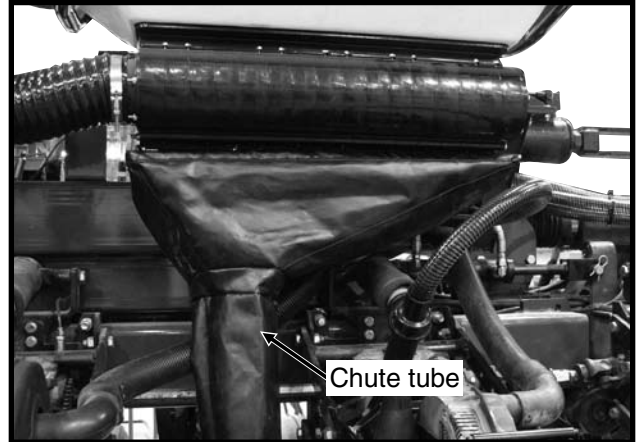

D032509212

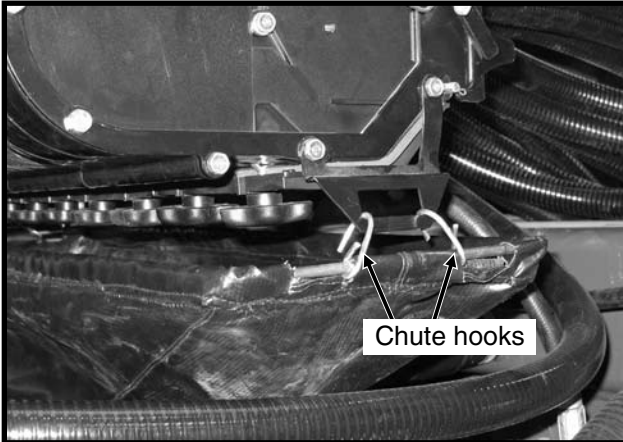

D032509208

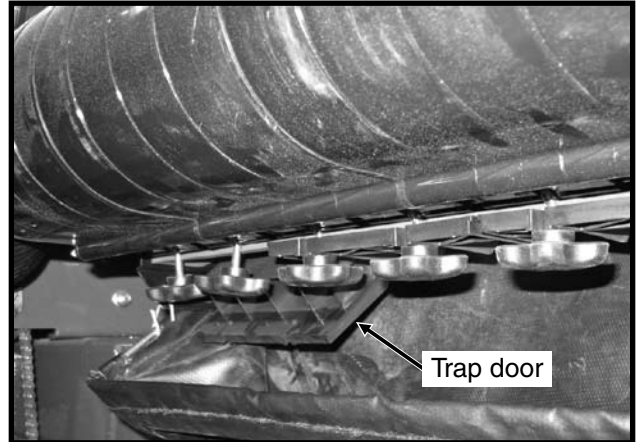

VACUUM FAN MOTOR VALVE BLOCK ASSEMBLY

A pressure relief valve in the hydraulic circuit prevents build up of oil pressure over 35 PSI in the case drain line when the vacuum fan motor is in operation. This valve will vent oil to the outside of the valve block through a drain hole in the aluminum valve block. This can occur whenever the case drain is connected improperly or pressure in the motor circuit builds.

See "Hydraulic Diagram - Vacuum Fan Motor System" in Maintenance section.

The valve block also contains a check valve that serves two purposes. This valve (a) prevents the vacuum fan from operating in the wrong direction if pressure is applied to the return side of the motor and (b) allows the fan to coast to a stop when the tractor hydraulic control is returned to the neutral position.

NOTE: If reverse pressure is applied the fan will turn at a reduced speed.

MACHINE OPERATION

ASD SCALE PACKAGE OPTION

IMPORTANT: Before power washing planter, remove display. Damage from high-pressure water may result.

ASD Scale Package is capable of:

- Providing seed weight or estimated acres remaining for each ASD hopper.
- Displaying total (gross) seed weight or estimated acres remaining for both hoppers combined.
- Warning operator when seed goes below a pre-defined level (when using a Kinze Vision® display).

Operation of ASD Scale Package display is controlled by buttons located on its face:

- Two screen-defined selection buttons.

D09140901



- Backlight ON/OFF button.
- UP and DOWN arrow buttons.
- Screen position is changed by loosening the thumb screw on RAM™ mount.

D09140906

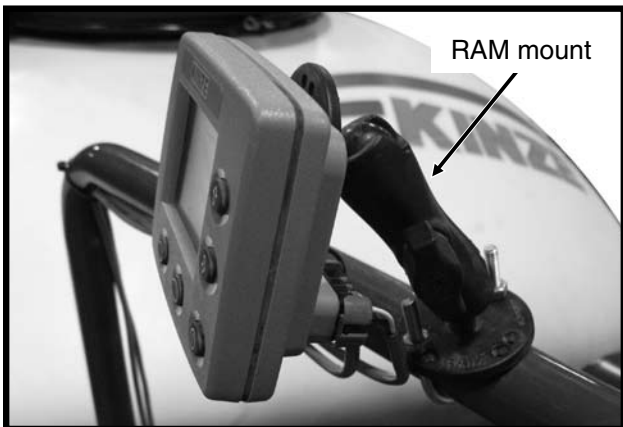

To set up the ASD Scale Package display:

1. From main screen (L / R), select SET-UP using left selection button.

D09140901



2. First set-up screen will appear and ALARM LEVEL box will be highlighted.

D09140902



3. To change alarm level amount, use right selection (SELECT) button – box will darken.
4. Use arrow buttons to change alarm level value; select BACK to save changes.
5. Use arrow buttons to highlight WEIGHT/ACRE MODE box; press SELECT to darken.
6. Arrow buttons will toggle mode from weight to acre mode. This selection affects how values are displayed in the display – either as pounds or as estimated acres of seed remaining. Press BACK to save changes.

MACHINE OPERATION

7. Press the down arrow key to select second set-up screen.

D09140903



- CALIBRATION# and SETUP# are automatic and do not need to be changed.
 - Display CONTRAST and BACKLIGHT affect the display screen. Select box to change and use arrow keys to change; press BACK to save changes.
8. Select BACK to return to main screen.

To enter seed information:

1. Highlight and select either L (left) or R (right) for the appropriate input screen.

D09140901



2. At input screen, L or R side is indicated at left side of screen and seed weight or acres remaining is on right side.

D09140904



3. Press arrow keys to select desired box; press SELECT to darken and use arrow keys to change.

NOTE: Seed information entered must be accurate for remaining estimated acres to calculate correctly.

- SEEDS/ACRE is population rate.
 - SEEDS/LB value comes from seed specifications.
 - ZERO is selected to zero hopper that is selected.
4. Select BACK to return to main screen.

MACHINE OPERATION

To monitor seed levels:

1. Main screen displays information for left and right hoppers.
2. Select either L or R for individual hopper status information.
3. Select BACK to return to main screen.
4. Press down arrow once or twice for GROSS screen to appear. This provides combined status information for both hoppers.

D09140905



5. Press down arrow again to return to main screen.

IMPORTANT: At end of planting season, remove display. Damage from sun and weather exposure may result.

MACHINE OPERATION

ROW MARKER OPERATION

D013109261

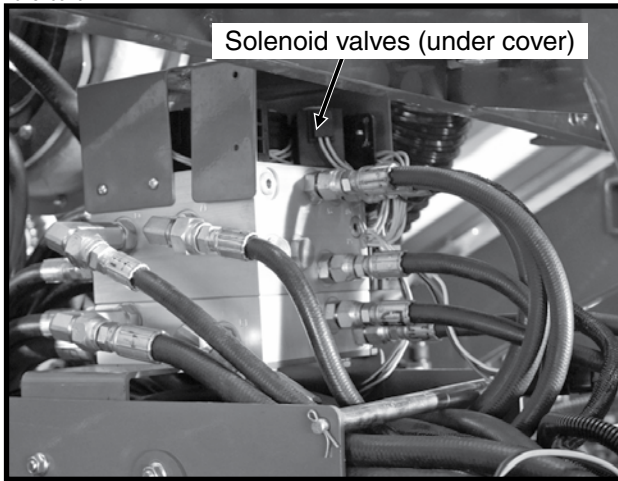

Two solenoid valves, located on the valve block on the rear R.H. side of the center frame, and a three position selector switch on the control console permit the operator to lower or raise the desired row marker.

See “Row Marker Speed Adjustment”.

1. On the control console, select which row marker you want to lower.
2. Operate hydraulic control to lower row marker.
3. If opposite row marker is to be used next, change control switch to other side.
4. At end of field, using hydraulic control, raise the lowered row marker.
5. After making the turn, using the hydraulic control, lower the pre-selected row marker.
6. Continue to follow this procedure.

D09110902



Three Position Selector Switch On Control Console

NOTE: Both row markers can be lowered by operating the switch in each position and operating the hydraulic control twice. The row markers will raise simultaneously with the hydraulic control in the raise position.

NOTE: Switch should be left in OFF position when planter is not in use. If left in ON position, it will discharge the tractor battery.

If the electrical system fails to operate properly:

- Check fuse.
- Check wiring connections.
- Check control switch.
- Check solenoid. SOLENOID HOUSING WILL BE MAGNETIZED WHEN ENERGIZED.

! DANGER: To avoid serious injury or death, care must be taken when operating row markers around overhead power lines.

MACHINE OPERATION

ROW MARKER SPEED ADJUSTMENT

The marker hydraulic system includes two flow control valves. One flow control valve sets the lowering speed of both markers and one sets the raising speed of both markers. To adjust marker speed, loosen the jam nut and turn the control(s) clockwise, or IN, to slow the travel speed and counterclockwise, or OUT, to increase the travel speed. The flow control(s) determine the amount of oil flow restriction through the valves, therefore varying travel speed of the markers. Tighten jam nut after adjustments are complete.

D032709201

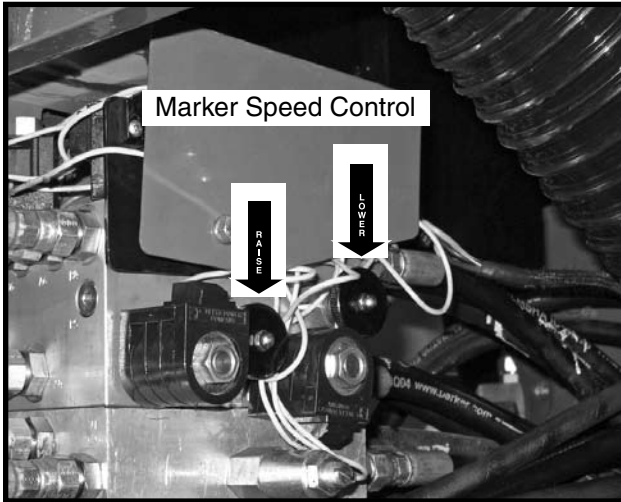

IMPORTANT: The flow controls should be properly adjusted before the row marker assembly is first put into use. Excessive row marker travel speed of the markers can damage the marker assembly.

NOTE: When oil is cold, hydraulics operate slowly. Make sure all adjustments are made with warm oil.

NOTE: On a tractor where the oil flow can not be controlled, the rate of flow of oil from the tractor may be greater than the rate at which the marker cylinder can accept the oil. The tractor hydraulic control will have to be held until the cylinder reaches the end of its stroke. This occurs most often on tractors with open center hydraulic systems.

On tractors equipped with flow control valves, row marker speed adjustment should be made with the tractor flow controls in maximum position. After row marker speed is set, the tractor flow controls can be adjusted to allow the hydraulic control to stay in detent during the marker raise or lower cycle.

⚠ DANGER: Extended row markers can make contact with power lines. Electrocutation can cause serious injury or death. Make sure area is clear of power lines before operating row markers.

MACHINE OPERATION

ROW MARKER LENGTH ADJUSTMENT

To determine the correct length at which to set the row marker assemblies, multiply the number of rows by the average row spacing in inches. This provides the total planting width. Adjust the marker extension so the distance from the marker disc blade to the center line of the planter is equal to the total planting width previously obtained. Both the planter and row marker assembly should be lowered to the ground when measurements are being taken. The measurement should be taken from the point where the blade contacts the ground. Adjust right and left row marker assemblies equally and securely tighten clamping bolts. An example of row marker length adjustment follows:

Number of rows	x	Row spacing (Inches)	=	Dimension Between Planter Center Line And Marker Disc Blade
----------------	---	----------------------	---	---

12 Rows x 30" Spacing = 360" Marker Dimension
16 Rows x 30" Spacing = 480" Marker Dimension

D013109206

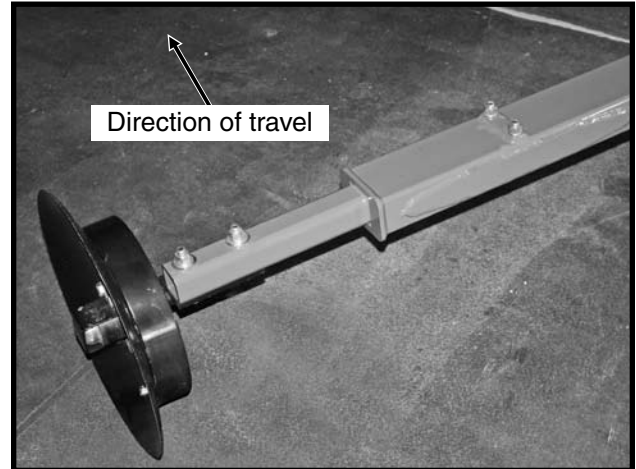

Marker Disc Blade Shown With Depth Band

The marker disc blade should be installed so the concave side of the blade faces outward to throw dirt away from the grease seals. The spindle assembly is slotted so the hub and blade can be angled to throw more or less dirt. To adjust the hub and spindle, loosen the 1/2" hardware and move the assembly as required. Tighten bolts to the specified torque.

IMPORTANT: A marker disc blade assembly that is set at a sharper angle than necessary will add unnecessary stress to the complete row marker assembly and shorten the life of bearings and blades. Set the blade angle only as needed to leave a clear mark.

A field test is recommended to ensure the markers are properly adjusted. After the field test is made, make any minor adjustments as necessary.

A notched marker disc blade, for use in more severe no till conditions, is available from KINZE® through your KINZE® Dealer. (Continued On Following Page)

MACHINE OPERATION

When using the even-row push row unit option, adjust marker extensions as shown below.

(TP1008)

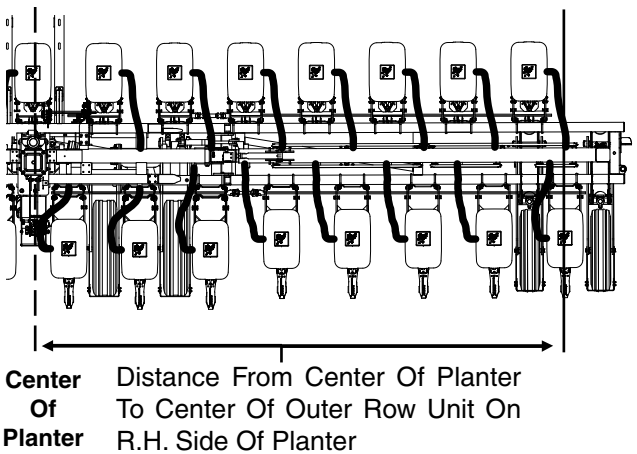
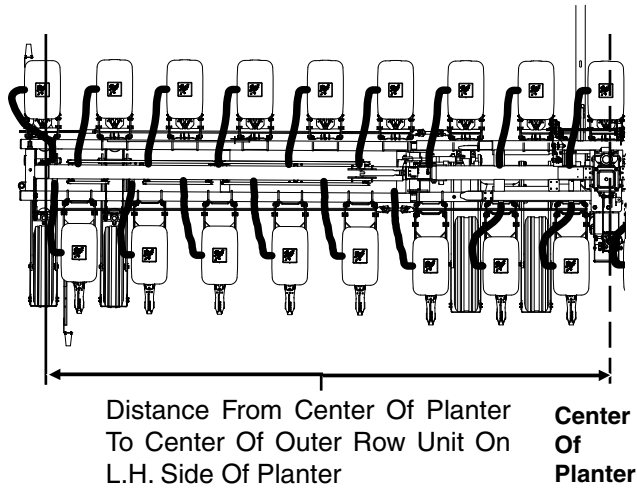

$$\begin{array}{l} \text{Center Of} \\ \text{Planter To} \\ \text{Center Of} \\ \text{Outer Row} \\ \text{Unit} \end{array} \times 2 + \begin{array}{l} 15'' \\ \text{Row} \\ \text{Spacing} \end{array} = \begin{array}{l} \text{Dimension} \\ \text{Between} \\ \text{Planter Center} \\ \text{Line And} \\ \text{Marker Blade} \end{array}$$

12 Row 30" With 12 Interplant® Push Row Units
 (L.H. Marker 180" x 2 + 15" = 375")
 (R.H. Marker 165" x 2 + 15" = 345")

16 Row 30" With 16 Interplant® Push Row Units
 (L.H. Marker 240" x 2 + 15" = 495")
 (R.H. Marker 225" x 2 + 15" = 465")

NOTE: If tractor hitch is offset 7 1/2" to the right of the center line of the tractor, add 7 1/2" to the marker dimension on the R.H. side of the planter and subtract 7 1/2" from the marker dimension on the L.H. side of the planter.

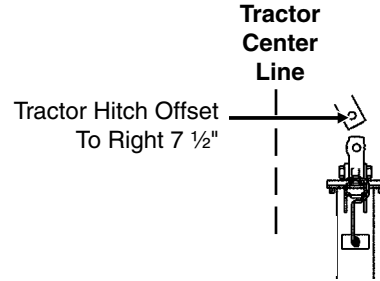

NOTE: Readjust markers when planting 30" rows.

NOTE: Readjust row markers when planting 30" rows.

Number Of Rows x Row Spacing (Inches)

=

Dimension Between Planter Center Line And Marker Blade

12 Rows x 30" Spacing = 360" Marker Dimension
 16 Rows x 30" Spacing = 480" Marker Dimension

IMPORTANT: Tractor hitch offset cannot be done if planter is equipped with planter mounted PTO hydraulic pump.

MACHINE OPERATION

KINZE COBALT™ SYSTEM

D09190804



The Cobalt electronic seed monitor system consists of a console, which is mounted on the tractor; seed tubes with computerized sensors, one of which is installed in each planter row unit; a primary harness, which connects the console to the planter harness; and a planter harness (junction Y-harness and/or harness extension where applicable), to which the individual seed tube sensors connect.

The Cobalt system allows manual control of air clutches and variable population control when planter is equipped with these options. It is not GPS compatible.

This system is compatible with all KINZE planters, and can be transferred between multiple vehicles to maximize the return on investment cost.

The Cobalt monitor has been built to withstand the harsh environment associated with today's agricultural industry. The weathertight enclosure is designed to seal out any dirt and moisture that is encountered during normal operating conditions.

NOTE: See operator manual supplied with KINZE Cobalt™ display for installation and programming.

KINZE VISION® SYSTEM

D012908205



The KINZE Vision display is a GPS-compatible universal monitor/controller for use in crop production and protection. It can easily be transferred between multiple vehicles through out the growing season to maximize your return on investment. The KINZE Vision display has its own internal memory for recording GPS and logging all information collected during various field activities. The KINZE Vision display has been built to withstand the harsh environment associated with today's agricultural industry. The weather tight enclosure is designed to seal out any dirt and moisture encountered during normal operating conditions.

NOTE: See operator manual supplied with KINZE Vision® display for installation and programming.

MACHINE OPERATION

POINT ROW CLUTCHES

D09030906

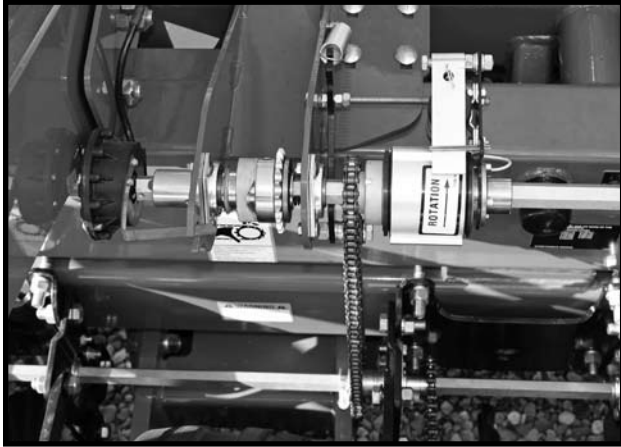

With the use of electric-activated clutches, which disengage the drive, either half of the planter may be shutoff for finishing up fields or long point row situations.

NOTE: Since the liquid fertilizer piston pump has its own drive wheel, liquid fertilizer application will not be affected by use of the point row clutch.

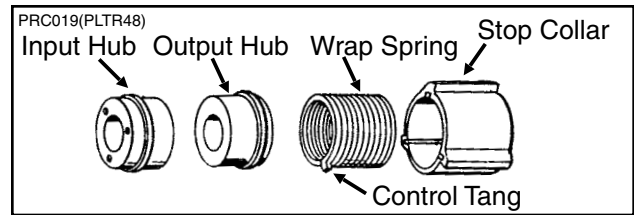

The point row clutch consists of a wrap spring riding on an input hub and an output hub. During operation the wrap spring is wrapped tightly over the hubs connecting them in a positive engagement. The greater the force of rotation the tighter the grip of the spring on the hubs.

Rotation in the opposite direction or stopping the spring from rotating prevents the transmission of torque from the input hub to the output hub, stopping the planter drive.

The input end of the spring is bent outward and is referred to as the control tang. The control tang fits into a slot in the stop collar that is located between the input and output hubs and over the wrap spring. If the stop collar is allowed to rotate with the input hub, the clutch is engaged. If the stop collar is stopped from rotating, the control tang connected to it is forced back and the spring opens. This allows the input hub to continue rotating without transmitting torque to the output hub; therefore, stopping the planter drive.

D012908205



KINZE Vision Display: Two switches in switch box are programmed to control the right and left sections of planter (refer to operator manual supplied with KINZE Vision display for programming instructions). No control switches will work until MASTER switch is turned ON (up position).

NOTE: Master switch should remain OFF when planter is not in use; tractor battery will discharge if left in ON position.

To disengage a planter section: MASTER switch must first be ON (up) then, move the appropriate control switch to ON (up) to shut off the desired section.

D09190804



Cobalt Display: Switches 1 (left section) and 2 (right section) in switch box control the two sections of the planter. Control switches will not work until MASTER switch is turned ON (up position).

MACHINE OPERATION

PLANTER MONITOR MODULE (PMM)

The PMM Magnetic Distance Sensor Package includes a planter-mounted module enclosure with cover and mounting hardware, seed tubes w/sensors, planter harness, planter monitor cable, shaft rotation sensors and magnetic distance sensor components. A KINZE Vision or Cobalt display and associated cab harnesses are also required.

D11200710a



HYDRAULIC WEIGHT TRANSFER TOOLBAR

The hydraulic weight transfer toolbar operates whenever planter is in motion and hydraulic seed rate drive is operating. It is factory set and does not require any additional adjustment.

HYDRAULIC SEED RATE DRIVE

Refer to KINZE Vision® or Cobalt™ operation manuals for information on setting and controlling the hydraulic seed rate system.

ROW UNIT AIR CLUTCHES

Air clutch system pressure should be set at 50 psi.

D01300904

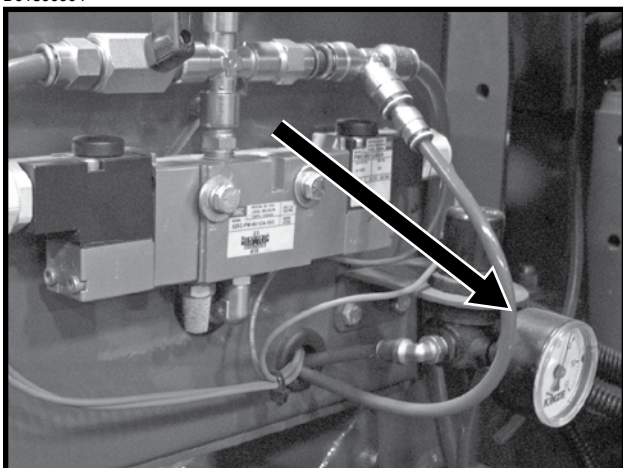

[Return to Table of Contents](#)

AUXILIARY WORK LIGHTS PACKAGE

A13752

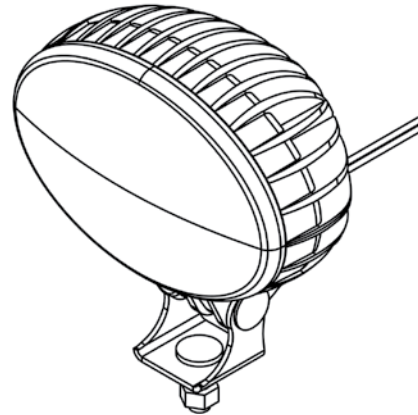

The optional auxiliary work lights package includes two LED lights equipped with trapezoid lens, hardware to mount lights on top of center lift cylinder, and the wiring harness to plug into existing planter light harness.

Lights are controlled by the work light switch on control console.

D09110902



MACHINE OPERATION

EVEN-ROW PUSH ROW UNIT

(TP1008)

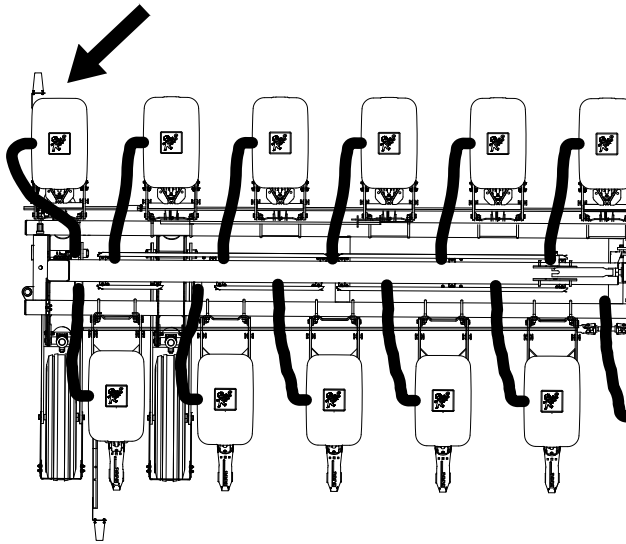

An Even-Row Push Row Unit Package is available to add one additional push row unit onto the L.H. side of the outer end of the front toolbar for use along with the Solid Row Interplant® Package.

NOTE: See “Row Marker Length Adjustment” in the Machine Operation section for determining correct length to set the row marker assemblies when planting with the even-row push row unit option.

AUXILIARY HYDRAULIC OPTION

A customer-supplied auxiliary hydraulic option may be added to provide 10 gpm of oil flow at rear of planter. It is designed for powering bulk seed handling equipment when planter is not in motion and is controlled by the same tractor hydraulic control as the seed rate hydraulic drive.

WARNING: Before installing auxiliary hydraulic components, make sure all pressure is removed from the hydraulic system.

Customer-supplied hoses, fittings, and hydraulic outlets are added to ports AUX1 and AUX2 on the lower valve block on back side of planter. Refer to “Hydraulic System Schematics” in the Maintenance section for additional information.

DANGER: Pressurized hydraulic fluid can penetrate body tissue and result in serious infection, injury, or death. Before applying pressure to the hydraulic system, make sure all connections are tight and that hoses and fittings have not been damaged. Leaks can be invisible. Keep away from suspected leaks. Relieve pressure in the hydraulic system before searching for leaks, disconnecting hoses, or performing any other work on the system. Fluid injected under the skin must be IMMEDIATELY removed by a surgeon familiar with this type of injury.

IMPORTANT: When using auxiliary hydraulic circuit, make sure MASTER switch is turned OFF on KINZE Vision® or Cobalt™ display, and planter is not in motion.

D01300904

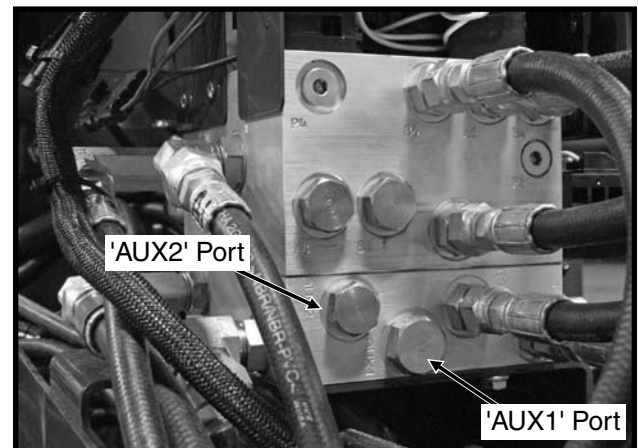

MACHINE OPERATION

DOUBLE DISC FERTILIZER OPENER

The double disc fertilizer openers should be positioned during assembly **to place fertilizer no closer than 2" to either side of the row.** If the planter frame is level and at proper 20" operating height, fertilizer depth will be approximately 4". Soil conditions can affect depth slightly.

The down pressure spring is factory preset at 250 lbs. down pressure but may be adjusted for various soil conditions. To adjust spring tension, loosen the jam nut with a $\frac{15}{16}$ " wrench and use a 1" wrench to turn the adjustment bolt clockwise to increase tension or counterclockwise to decrease tension. Securely tighten the jam nut upon completion of tension adjustment. Do not attempt to set opener depth with spring pressure. The opener is designed to operate against a depth stop and spring up when encountering a foreign object or hard ground.

IMPORTANT: Do not operate the double disc openers at full down pressure tension when planting in rocky ground. Chipping of the disc blades will occur.

A gap of $\frac{1}{32}$ " to $\frac{1}{16}$ " should be maintained between the opener blades at the closest point. Blade adjustment is made by moving inside spacer washers to the outer side of the blade. After making this adjustment, check to be sure bearing assembly rivets are not contacting the shank.

D06259919

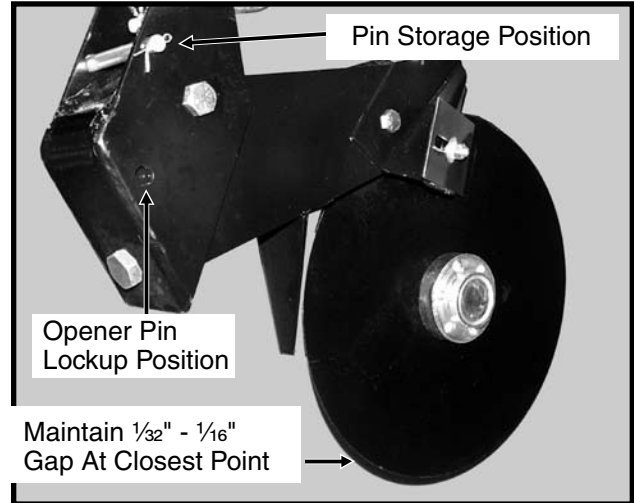

The outer scrapers on each disc blade may also be adjusted to make up for wear that may occur. Make sure the scrapers are adjusted to allow only slight contact with the blades.

The opener assembly is designed to be locked in a raised position when the fertilizer attachment is not in use or during storage. To lock the opener up, first raise the planter and place blocks under the openers. Then lower the planter until the hole in the pivot section aligns with the hole in the mounting bracket. Remove the lockup pin from the storage position in the mounting bracket and install it through the lockup hole and secure with cotter pins.



WARNING: Always install all cylinder lockup devices before working under the unit.

MACHINE OPERATION

NOTCHED SINGLE DISC FERTILIZER OPENER

The notched single disc fertilizer opener is designed for use in minimum and no till planting conditions. Placement of fertilizer with the 16 3/4" diameter notched single disc fertilizer opener is recommended at 2 1/2" - 3" from the row. The opener is designed to hold the blade at a set-angle so the knife and drop tube operate in the shadow of the blade. **Never locate the opener to place fertilizer closer than 2".**

⚠ WARNING: Spring under pressure. DO NOT disassemble.

(A12429a/B0297)

Depth Adjustment Cap Screws - Recommended Maximum Operating Depth 4" (Middle Cap Screw Holds Blade Angle But Must Be Loosened To Adjust Depth And Tightened First To Set Blade Angle.)

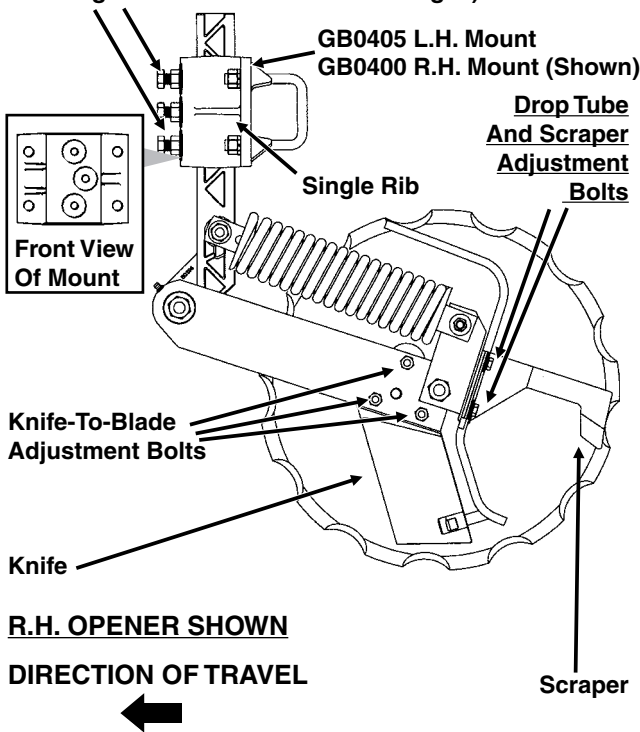

Adjust knife-to-blade contact on each fertilizer opener so blade will turn by hand with slight resistance, but will not coast or freewheel. In dry, loose soil the knife adjustment is critical. If adjustment is not maintained, soil or residue may wedge between knife and blade, resulting in the blade not turning. If the knife is adjusted too tight, the blade will not turn causing the blade to push soil and residue. **Knife adjustment is made using the three 3/8" mounting carriage bolts** and pivot pad on the knife. Because of blade runout, rotate blade one full revolution after adjustment. Readjust knife to the blade's tight spot as needed. **Never strike the knife with a heavy object or damage may occur.**

Return to Table of Contents

Using the slotted mounting holes in the drop tube mount, **adjust fertilizer drop tube** behind the knife so it is protected from soil contact and wear. The liquid drop tube should be adjusted 1/4"-3/8" from the opener blade while keeping it behind the knife. Insert a flat bladed pry bar between the knife and drop tube just above the drop tube tab as shown below. Bend the tube inward toward the disc blade to obtain the desired 1/4"-3/8" adjustment.

D01040702

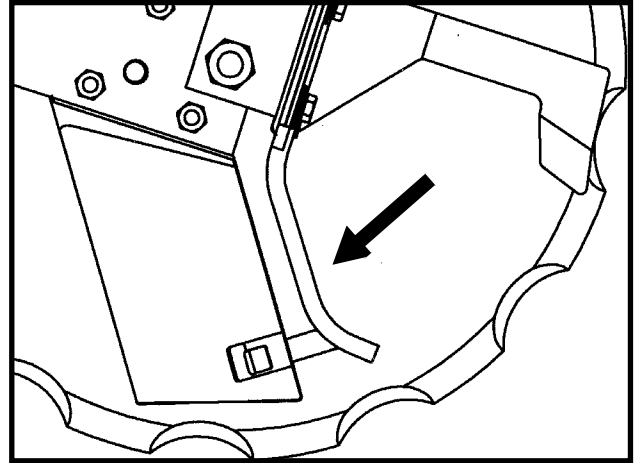

NOTE: Adjusting the liquid drop tube will ensure it is out of the path of the soil flow across the knife. Drop tube and tab will wear quickly if not adjusted correctly.

Adjust scraper to just touch the opener blade. As the mounting hardware is tightened, the scraper is drawn tighter to the blade. After adjustment, rotate opener blade to be sure blade will turn by hand with slight resistance, but will not coast or freewheel.

Adjust blade depth on each row using the cap screws and jam nuts located on the opener mount. The blade can be adjusted to allow a maximum 4" blade depth. Check fertilizer hose clearance (If Applicable) after adjusting opener depth. Torque cap screws and jam nuts to 57 ft. lbs.

MACHINE OPERATION

NOTE: The blade cuts through the soil at an angle relative to the direction of travel. For this reason and to ensure proper operation, the cast mount should be oriented so the front and bottom of the blade tilt towards the knife.

D01160802

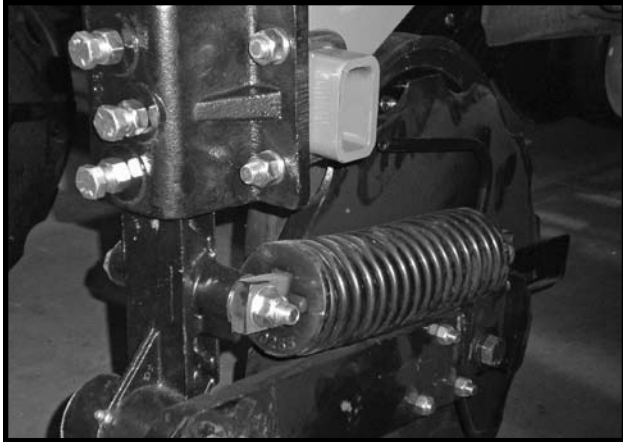

R.H. Opener (B0400)

D01160801

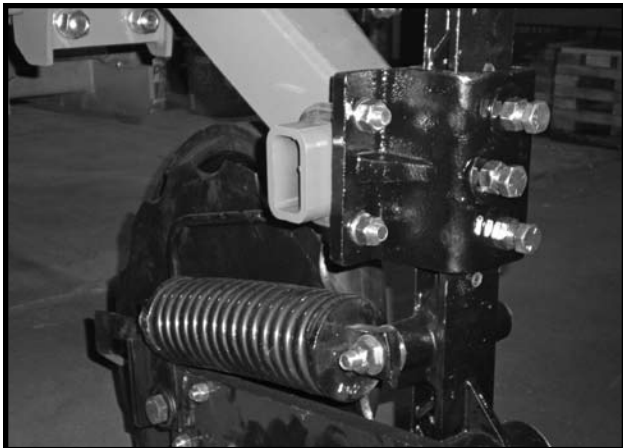

L.H. Opener (B0405)

FRTZ296

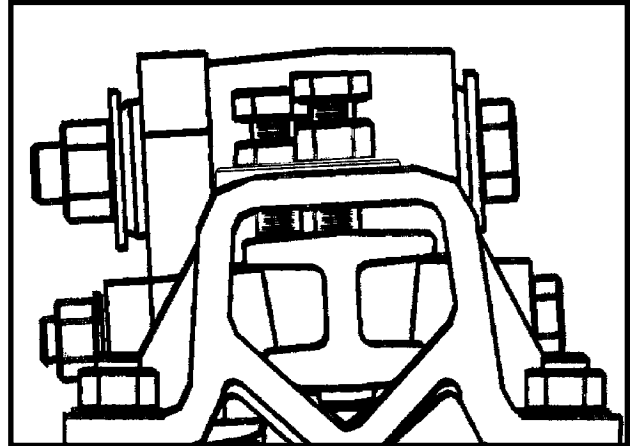

D070103100

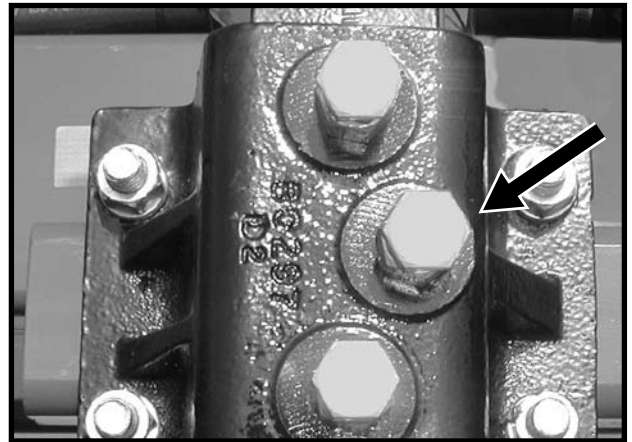

NOTE: Recommended maximum operating depth is 4". To adjust depth: (a) Loosen depth adjustment cap screws. (b) Adjust depth to desired setting. (c) Tighten upper and lower cap screws slightly to hold opener arm in place. (d) Tighten middle cap screw to set the opener arm angle. (e) Tighten upper and lower cap screws and all jam nuts.

MACHINE OPERATION

RESIDUE WHEEL ATTACHMENT FOR NOTCHED SINGLE DISC FERTILIZER OPENER

D052201104



The residue wheel attachment for the notched single disc fertilizer opener is designed for applications where row unit mounted residue wheel attachments cannot be installed. The residue wheel is attached to the notched single disc fertilizer opener using $\frac{5}{8}$ " x $7\frac{1}{2}$ " and $\frac{1}{2}$ " x $6\frac{1}{2}$ " hardware.

Maximum depth is set by lifting the residue wheel and moving the adjustment lever down to increase depth or up to decrease depth in 1" increments (in relation to blade depth setting). Adjust all rows the same. Down force on the residue wheel is maintained by a torsion spring and is not adjustable.

Due to space restrictions, the residue wheel attachment for the notched single disc fertilizer opener is not applicable to Model 3600 Planters equipped with Interplant® push row units and notched single disc fertilizer openers.

DEPTH / GAUGE WHEEL ATTACHMENT FOR NOTCHED SINGLE DISC FERTILIZER OPENER

D061101202a

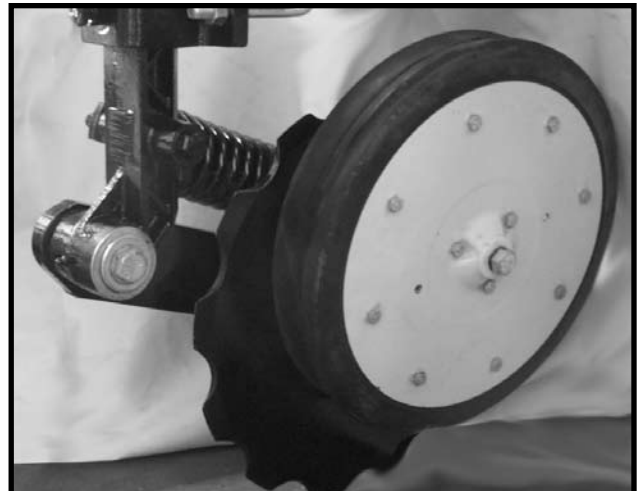

The depth/gauge wheel attachment for the notched single disc fertilizer opener is designed for use in situations where additional gauging is required to maintain desired fertilizer opener depth. The depth/gauge wheel is attached to the notched single disc fertilizer opener using a mounting block fastened to the pivot arm using $\frac{5}{8}$ " hardware through the disc blade hub w/bearing.

Depth adjustment is made by using the adjustment holes in the depth/gauge wheel mounting block.

If equipped with the depth/gauge wheel mounting block with 3 holes, moving the depth/gauge wheel increases/decreases depth in approximate 1" increments in relation to the blade depth setting made at the vertical mounting post.

(FRTZ256a)

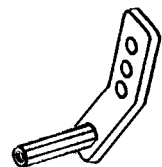

Due to space restrictions, the depth/gauge wheel attachment for the notched single disc fertilizer opener is not applicable to Model 3600 Planters equipped with Interplant® push row units and notched single disc fertilizer openers.

MACHINE OPERATION

HD SINGLE DISC FERTILIZER OPENER

D062601103

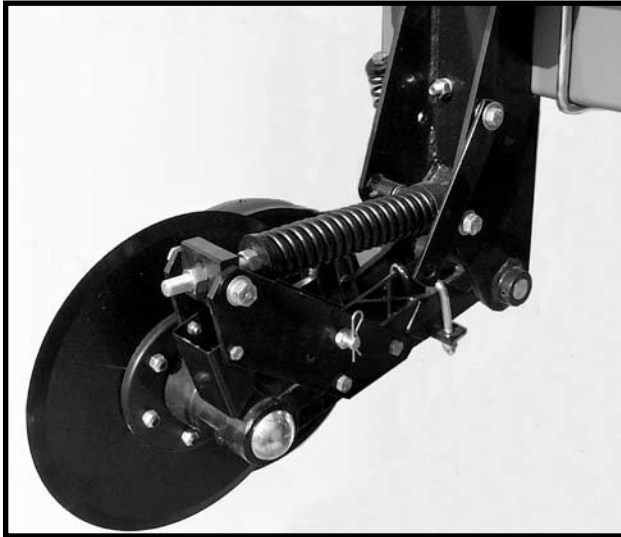

Placement of fertilizer with the HD single disc fertilizer opener is recommended at 3 1/2" - 4" from the row.

If planter frame is level and at 20" operating height, maximum blade depth for placement of fertilizer is approximately 5". Soil conditions can affect depth slightly.

To adjust blade depth, raise the planter to remove weight from the fertilizer opener. Loosen inside adjustment nut (A) with 1 1/8" wrench. Turn outside nut (B) clockwise to decrease blade depth or counterclockwise to increase blade depth. One full turn of the blade depth adjustment nut changes blade depth 3/8". Tighten inside nut tight against block (C). Adjust all fertilizer openers to the same depth.

L0114(PLTR3)

DIRECTION OF TRAVEL



(Overhead View)

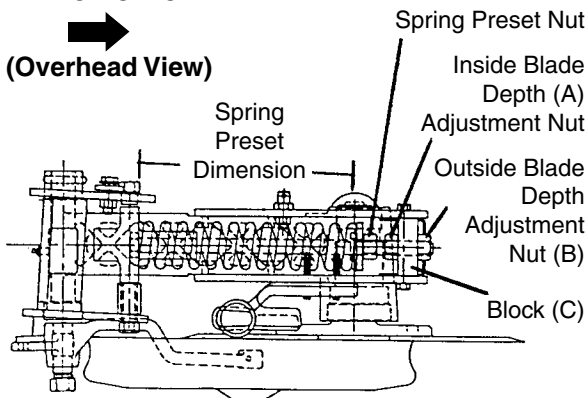

R.H. Configuration Shown

Return to Table of Contents

Fertilizer opener down pressure can be adjusted from 250 lbs. to 640 lbs. **To make down pressure adjustments**, raise planter to remove weight from the fertilizer opener and turn spring preset nut clockwise to increase down pressure and counterclockwise to decrease down pressure. Adjust all rows to a similar setting. Minimal spring pressure for acceptable operation is recommended. See chart for spring length setting specifications.

SPRING PRESET DIMENSION	DOWN PRESSURE (LBS.)
11"	250
10 3/4"	320
*10 1/2"	370
10 1/4"	450
10"	520
9 3/4"	580
9 1/2"	640

* Suggested initial setting.

NOTE: DO NOT adjust spring preset dimension to less than 9 1/2".

NOTE: Excessive down pressure can cause uplift on the planter frame and affect performance of the machine. When lowered to planting position, planter frame should be at a height of approximately 20". In loose ground conditions, excessive down pressure can cause openers to run too deep and push dirt ahead of opener and may stop soil press wheel and/or opener blade from turning.



WARNING: Always install all safety lockup devices before working under the machine.

IMPORTANT: Do not operate HD single disc fertilizer openers at full down pressure tension when planting in rocky ground. Chipping or breakage of the blades will occur.

The spring loaded dry fertilizer drop tube/scrapper should be adjusted periodically to maintain 1/8" gap between drop tube and opener blade. If this dimension is not maintained the fertilizer may not drop into the proper location.

Loosen scraper adjustment bolt. Slotted hole in scraper allows up or down adjustment.

FOC016(PLTR4)

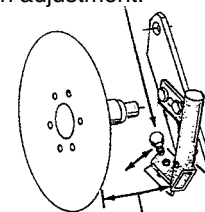

Adjust scraper to maintain 1/8" gap between drop tube and opener blade. Distance is exaggerated in above illustration.

MACHINE OPERATION

Maintain liquid fertilizer drop tube/scrapper adjustment as shown below.

(INS16a)

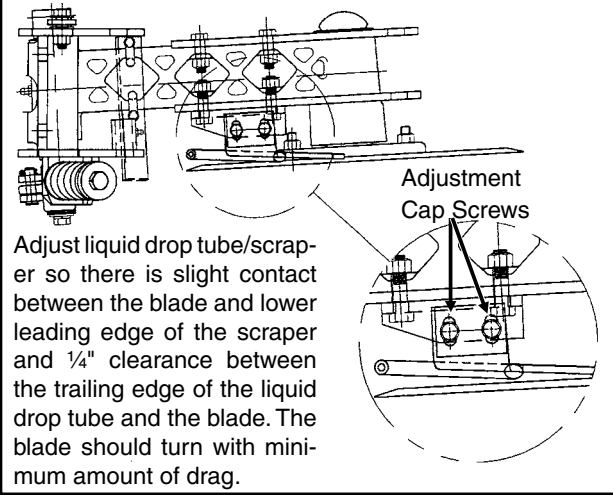

Additional press wheel down pressure may be desirable in heavy moist soils. **To increase press wheel spring pressure** turn press wheel spring adjustment bolt clockwise.

D121202101

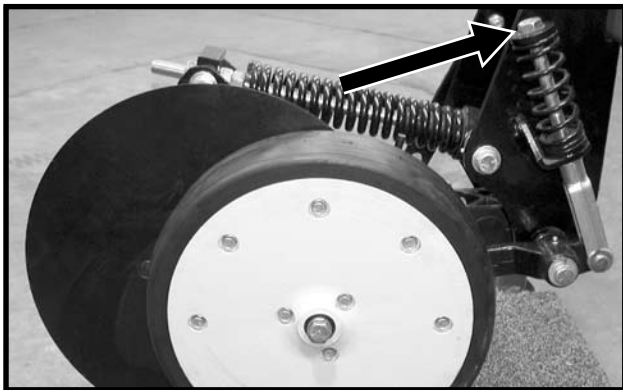

NOTE: The soil press wheel is not intended to be used for gauging fertilizer opener operating depth.

The HD single disc fertilizer opener is designed to be locked in a raised position when the fertilizer attachment is not in use or during storage.

To lock the HD single disc fertilizer opener in the raised position, proceed as follows:

- STEP 1** With the planter in the planting position, remove outside blade depth adjustment nut. ("B" in illustration on previous page.)
- STEP 2** Raise planter until adjustment bolt clears adjustment block.

STEP 3 Raise spring to clear blade assembly and at the same time raise blade assembly until storage strap can be positioned onto lock-up pin and install hair pin clip.

STEP 4 Reinstall depth adjustment nut and tighten.

D062601102

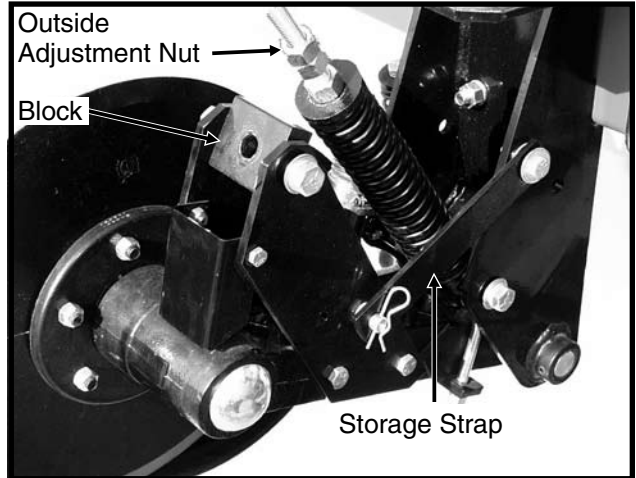

NOTE: The HD single disc fertilizer opener is equipped with a lockup bar that automatically raises and locks the soil press wheel when the blade assembly is raised.

FOC016(PLTR5b)

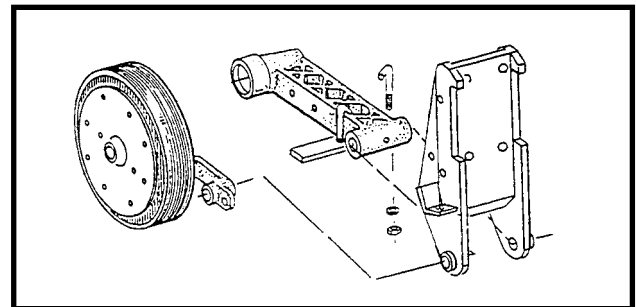

LIQUID FERTILIZER ATTACHMENT

NOTE: An optional low rate check valve is available for installation in-line between the liquid fertilizer squeeze or piston pump and the liquid fertilizer openers to ensure equal distribution of product at low rates. The check valves also eliminate the need for an anti-siphon loop if the valves are installed as close as possible to the fertilizer opener drop tube.

(FRTZ208)

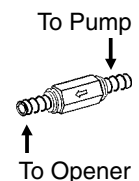

MACHINE OPERATION

OPTIONAL PISTON PUMP

NGP6055

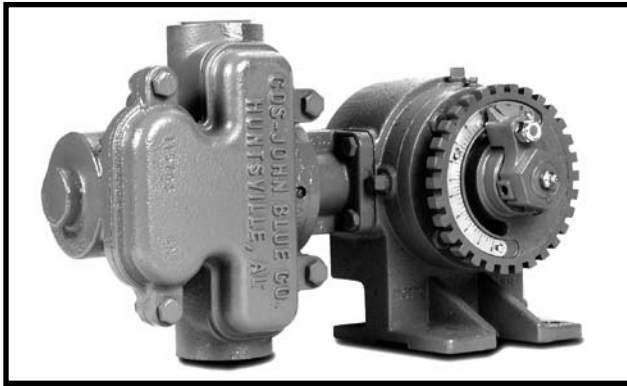

If the machine is equipped with the piston pump option, the rate of liquid fertilizer application is determined by the piston pump settings.

The delivery rate chart found at the end of this section provides an approximate application rate only. Actual delivery will vary with temperature and the particular fertilizer being used.

To adjust delivery rate, loosen the $\frac{3}{8}$ " lock nut that secures the arm with the pointer and rotate the scale flange until the pointer is over the desired scale setting. The adjustment wrench will facilitate rotation of the scale flange. Tighten the $\frac{3}{8}$ " lock nut being careful not to over tighten.

(A12330b)

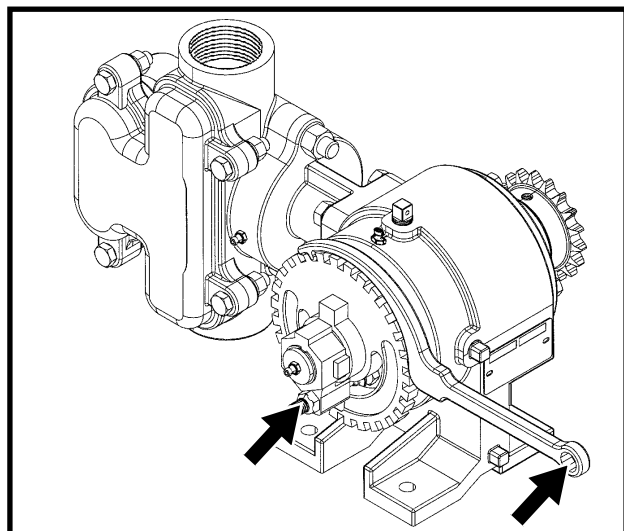

The operator and instruction manual shipped with the pump and flow divider should be kept and stored with this manual for future reference.

NOTE: Periodically check flow to all rows. If one or more lines are plugged, set rate will be delivered to remaining rows.

Return to Table of Contents

CLEANING

The tanks and all hoses are made of sturdy plastic and rubber to resist corrosion. However, the tanks, hoses and metering pump should be thoroughly cleaned with water at the end of the planting season or prior to an extended period of non-use. Do not allow fertilizer to crystalize due to cold temperature or evaporation.

The strainer, located between the piston pump and ball valve (On machines equipped with the piston pump.), should be taken apart and cleaned daily. Remove the end cap to clean the screen.

(INS220)

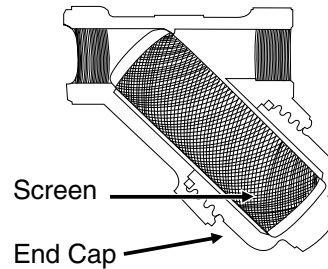

See "Piston Pump Storage" (If Applicable) in the Maintenance section of this manual.

MACHINE OPERATION

LIQUID FERTILIZER PISTON PUMP APPLICATION RATES GALLONS PER ACRE

Model NGP-6055 Piston Pump With 18 Tooth Sprocket (Planter Equipped With One Piston Pump)

Pump Setting	1	2	3	4	5	6	7	8	9	10
12 Row 30"	5.1	10.4	15.5	20.6	25.8	31.0	36.2	41.3	46.5	51.7
16 Row 30"	3.4	6.9	10.3	13.7	17.1	20.6	24.0	27.5	30.9	34.3

The chart above is for planters equipped with contact drive. See "Tire Pressure" for recommended tire pressures. This chart is based on average wheel slippage and liquid viscosities.

Measure and weigh one gallon of actual fertilizer solution to determine exact application rate. This chart was calculated based on a solution weighing ten pounds per gallon.

NOTE: Fertilizer application rates can vary from the above chart. To prevent application miscalculations, make field checks to be sure you are applying fertilizer to all rows at the desired rate.

NOTE: Flow to all rows should be checked periodically. If one or more lines are plugged, the desired rate will be delivered to the remaining rows keeping total application at the desired rate.

To check the exact number of gallons your fertilizer attachment will actually deliver on a 30" row spacing, proceed as follows:

Remove the hose from one or more of the fertilizer openers and insert it into a collection container which has been secured to the planter frame. Engage the fertilizer attachment and drive forward for 174'. Measure the fluid ounces caught in the container and multiply that amount by 100. Divide that amount by 128. The result will be the gallons of fertilizer delivered per acre when planting in 30" rows. Rinse the collection container and repeat test on other rows if necessary.

MACHINE OPERATION

TRANSPORTING THE PLANTER

⚠ WARNING: Always make sure safety/warning lights, reflective decals and SMV sign are in place and visible prior to transporting the machine on public roads. In this regard, check federal, state/provincial and local regulations.

IMPORTANT: Avoid transporting planter with hoppers loaded whenever possible. When it is necessary to transport the planter with the hoppers loaded, the added weight should be distributed evenly on the planter frame before rotating the planter.

⚠ WARNING: Install all safety lockup devices and safety locking pins before transporting the planter.

METRIC CONVERSION TABLE

MULTIPLY	BY	TO GET
Inches (in.)	x 2.54	= centimeters (cm)
Inches (in.)	x 25.4	= millimeters (mm)
Feet (ft.)	x 30.48	= centimeters (cm)
Acres	x 0.405	= hectares (ha)
Miles per hour (mph)	x 1.609	= kilometers per hour (Km/h)
Pounds (lbs.)	x 0.453	= kilograms (kg)
Bushels (bu.)	x 35.238	= liters (l)
Gallons (gal.)	x 3.785	= liters (l)
Pounds per square inch (psi)	x 6.894	= kilopascals (kPa) (100 kPa = 1 bar)
Inch pounds (in. lbs.)	x 0.113	= newtons-meters (N•m)
Foot pounds (ft. lbs.)	x 1.356	= newtons-meters (N•m)
Centimeters (cm)	x .394	= inches (in.)
Millimeters (mm)	x .0394	= inches (in.)
Centimeters (cm)	x .0328	= feet (ft.)
Hectares (ha)	x 2.469	= acres
Kilometers per hour (Km/h)	x 0.621	= miles per hour (mph)
Kilograms (kg)	x 2.208	= pounds (lbs.)
Liters (l)	x 0.028	= bushels (bu.)
Liters (l)	x 0.264	= gallons (gal.)
Kilopascals (kPa) (100 kPa = 1 bar)	x 0.145	= pounds per square inch (psi)
Newtons-meters (N•m)	x 8.85	= inch pounds (in. lbs.)
Newtons-meters (N•m)	x 0.738	= foot pounds (ft. lbs.)

HALL EFFECT SENSOR

Hall Effect sensor should be set within 1/8" of pick-up disc.

D032709204

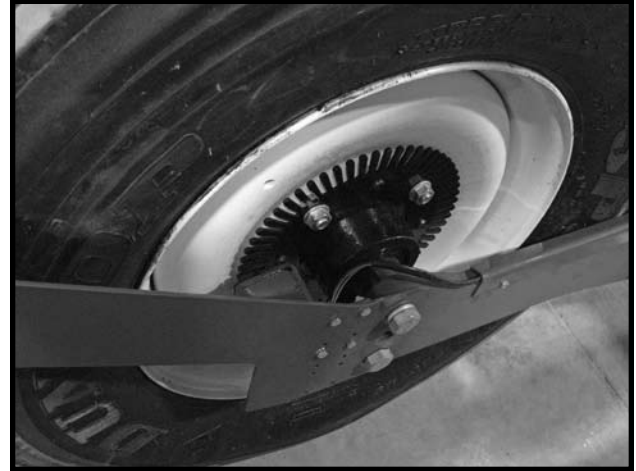

MACHINE OPERATION

PLANTING SPEED

Planters are designed to operate within a speed range of 2 to 8 MPH. Generally, higher ground speeds will cause more variation in seed spacing. Speeds above 5.5 MPH are typically not recommended. See “Planting And Application Rate Charts” in Seed Meter Operation/Maintenance section for specific recommendations.

FIELD TEST

With any change of field and/or planting conditions, seed size or planter adjustment, we recommend a field test be made to ensure proper seed placement and operation of row units.

- Check the planter for fore to aft and lateral level operation. See “Leveling The Planter”.
- Check **all** row units to be certain they are running level. When planting, the row unit parallel arms should be approximately parallel to the ground.
- Check row markers for proper operation and adjustment. See “Row Marker Length Adjustment”, “Row Marker Speed Adjustment” and “Row Marker Operation”.
- Check for proper application rates and placement of granular chemicals on **all** rows. See “Checking Granular Chemical Application Rate”.
- Check for desired depth placement and seed population on **all** rows. See “Checking Seed Population”.
- Check for proper application rates of fertilizer on **all** rows. See proper “Fertilizer Application Rate Chart”.

After the planter has been field tested, reinspect the machine.

- Hoses And Fittings
- Bolts And Nuts
- Cotter Pins And Spring Pins
- Drive Chain Alignment

MACHINE OPERATION

REAR TRAILER HITCH

The Rear Trailer Hitch is used to tow a 3 or 4 wheel wagon behind the planter. A spring, chain and mounting bracket are used to support the 1 ¼" feed hose from the hitch to the piston pump. This extra length or loop is required to allow the planter to be moved into transport position without stretching the hose.

IMPORTANT: Maximum allowable hitch weight is 200 lbs. Gross towing weight should not exceed 6000 lbs. or the equivalent of a loaded 500 gallon tank and running gear.

IMPORTANT: Connection points are provided on the rear trailer hitch for connection of customer-supplied transport safety chains.

NOTE: Periodically check feed hose for kinks to prevent restricted delivery rate.

Conventional Planter Shown

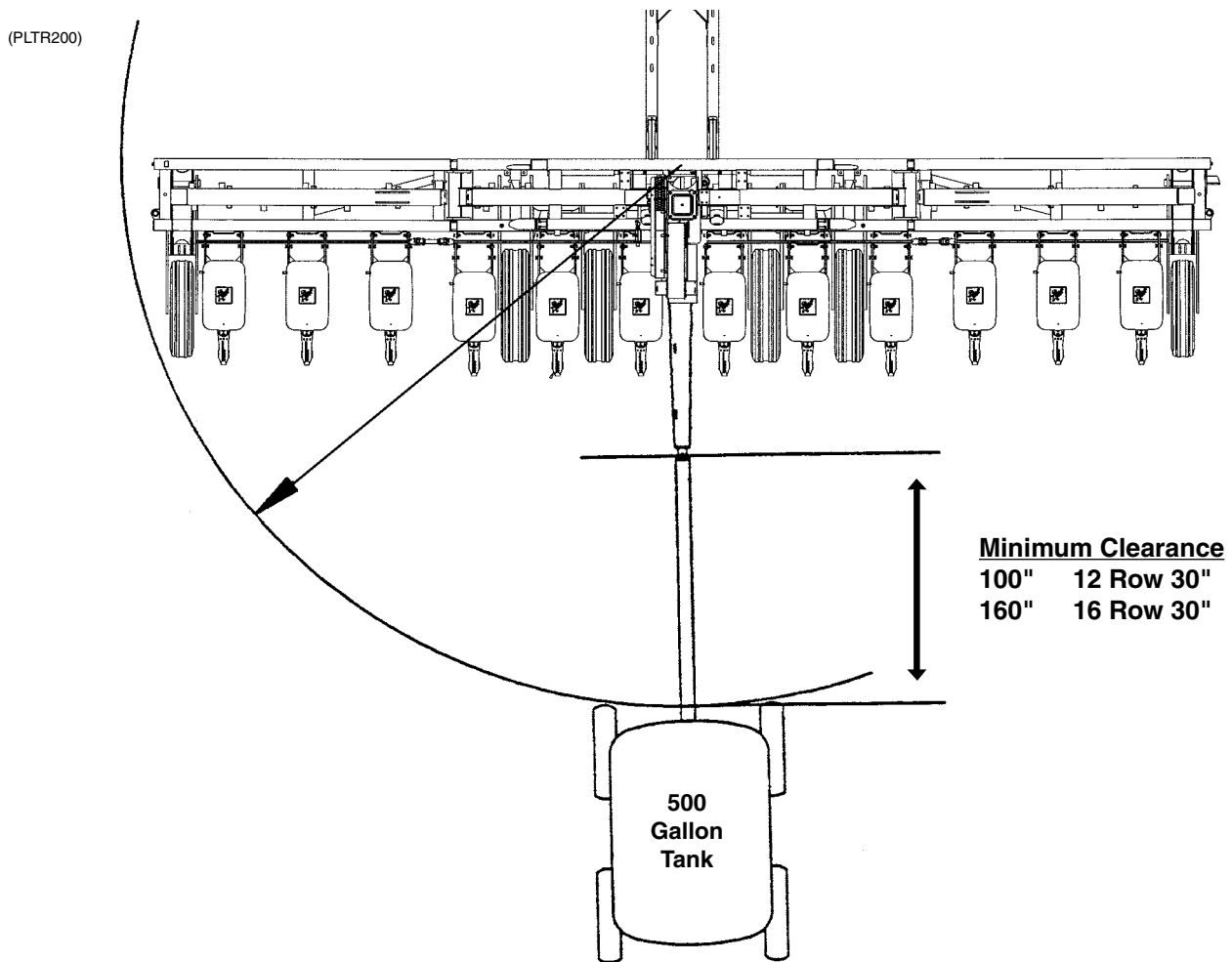

Note: Minimum tank hitch length required to allow planter to be rotated to transport position.

MACHINE OPERATION

CHECKING SEED POPULATION

1. Tie up one or more sets of closing wheels by running a chain or rubber tarp strap between the hopper support panel and closing wheels. It may be necessary to decrease closing wheel arm spring tension.

(RU113g)

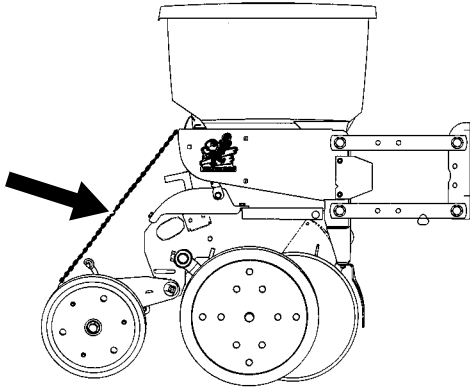

2. Plant a short distance and check to see if seed is visible in the seed trench. Adjust planting depth to a shallower setting if seed is not visible and recheck.

D020705102

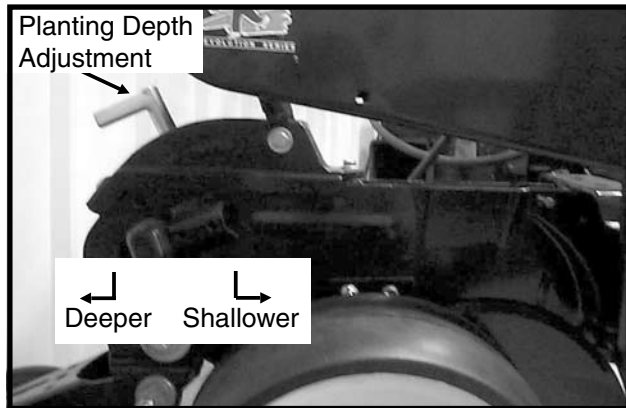

3. Measure $\frac{1}{1000}$ of an acre. See chart for correct distance for row width being planted. For example, if planting 30" rows $\frac{1}{1000}$ of an acre would be 17' 5".

LENGTH OF ROW IN FEET AND INCHES						
Fraction Of Acre	Row Width					
	15"	18"	19"	30"	36"	38"
$\frac{1}{1000}$	34' 10"	29' 0"	27' 8"	17' 5"	14' 6"	13' 10"

NOTE: When planting with closing wheels raised and planting depth set shallow, seeds may bounce or roll affecting seed spacing accuracy.

4. Count seeds in measured distance.
5. Multiply the number of seeds placed in $\frac{1}{1000}$ of an acre by 1000. This will give you total population.

EXAMPLE: With 30" row spacing 17' 5" equals $\frac{1}{1000}$ acre.

26 Seeds			
Counted	x	1000	= 26,000 Seeds Per Acre

Seed count can be affected by drive ratio between drive wheel and seed meter, tire pressure and/or seed meter malfunction.

If seed check shows the average distance between seeds in inches is significantly different than the seed rate chart indicates, first check drive ratio between drive wheel and seed meter. Check drive wheel air pressure, check for incorrect sprocket(s) in driveline and check drive and driven sprockets on transmission(s) for proper selection.

Second, check for seed meter malfunction. For example, if spacing between kernels of corn at the transmission setting being used is 8" and a gap of 16" is observed, a seed cell has lost its seed and not functioned properly. If two seeds are found within a short distance of each other, the seed cell has metered two seeds instead of one.

See "Seed Metering System Troubleshooting" in the Seed Meter Operation/Maintenance section of this manual.

MACHINE OPERATION

Determining Pounds Per Acre

To determine pounds per acre:

Seeds Per Acre On Chart	÷	Seeds Per Pound From Seed Tag On Bag	=	Pounds Per Acre
-------------------------------	---	---	---	-----------------------

To determine bushels per acre:

Pounds Per Acre	÷	Unit Weight Of Seed	=	Bushels Per Acre
--------------------	---	------------------------	---	---------------------

The unit weight of:

- 1 Bushel Soybeans = 60 Pounds
- 1 Bushel Milo/Grain Sorghum = 56 Pounds
- 1 Bushel Cotton = 32 Pounds

If seeds per pound information is not available the following is an average:

- 2,600 seeds per pound for medium size soybeans
- 15,000 seeds per pound for medium size milo/grain sorghum
- 4,500 seeds per pound for medium size cotton

If seed population check shows planting rate is significantly different than seed rate chart shows or if a particular meter is not planting accurately, see "Seed Metering System Troubleshooting" in Seed Meter Operation/Maintenance section of this manual.

CHECKING GRANULAR CHEMICAL APPLICATION RATE

Many things can affect the rate of delivery of granular chemicals such as temperature, humidity, speed, ground conditions, flowability of different material or any obstruction in the meter.



WARNING: Agricultural chemicals can be dangerous if not selected and handled with care. Always read and follow directions supplied by the chemical manufacturer.

A field check is important to determine correct application rates.

D05149901



To check, fill insecticide and/or herbicide hoppers. Attach a calibrated vial to each granular chemical meter. Lower the planter and proceed as follows.

NOTE: It is not necessary for seed meter clutch to be engaged during test. Disengage clutch to avoid dropping seed.

Drive 1320 feet at planting speed. Weigh the chemical in ounces that was caught in one vial. Multiply that amount by the factor shown to determine pounds per acre.

POUNDS PER ACRE FACTOR FOR GIVEN ROW WIDTH	
Row Width	Factor
30"	0.83
36"	0.69
38"	0.65

EXAMPLE: You are planting 30" rows. You have planted for 1320 feet at the desired planting speed. You caught 12.0 ounces of chemical in one vial. 12.0 ounces times 0.83 equals 9.96 pounds per acre.

NOTE: It is important to check calibration of all rows.

Metering Gate

Use the metering gate setting for distributing insecticide or herbicide as a starting point. The charts are based on a 5 miles per hour planting speed. For speeds faster than 5 miles per hour a higher gate setting should be used. For speeds slower than 5 miles per hour a lower gate setting should be used.

MACHINE OPERATION

DRY INSECTICIDE APPLICATION RATES APPROXIMATE POUNDS/ACRE AT 5 MPH FOR VARIOUS ROW WIDTHS

Meter Setting	30" Rows
CLAY GRANULES	
10	4.9
11	5.4
12	6.1
13	6.9
14	7.7
15	8.5
16	9.6
17	10.7
18	11.4
19	13.1
20	14.2
21	15.5
22	16.4
23	17.2
24	18.8
25	20.9
26	23.0
27	24.1
28	25.4
29	27.8
30	29.6
SAND GRANULES	
5	2.9
6	4.9
7	5.3
8	6.3
9	7.8
10	8.9
11	10.2
12	11.2
13	12.6
14	14.1
15	15.5
16	17.5
17	19.4
18	21.8
19	24.3
20	25.7
21	27.6
22	29.6
23	32.0
24	34.4
25	36.9

NOTE: The above chart represents average values and should be used only as a starting point. The granular chemical flows through the given meter opening at a nearly uniform rate regardless of roller speed. Your actual rate will vary depending upon the insecticide you are using, your planting speed and your plant population. Planting speed/ground speed has the greatest effect on application rate.

Your actual rate must be checked in the field with the actual insecticide that you are using and at the speed and population at which you will be planting. See "Checking Granular Chemical Application Rate" page for additional information.



WARNING: Agricultural chemicals can be dangerous if not selected and handled with care. Always read and follow directions supplied by the chemical manufacturer.

ROW UNIT OPERATION

PLANTING DEPTH

Planting depth is maintained by the row unit gauge wheels. To increase or decrease the planting depth, first raise the planter to remove weight from the wheels. Then push down on the depth adjustment handle and reposition it forward to decrease depth or rearward to increase planting depth. Adjust all units to the same setting initially. Then lower the planter and check operation and planting depth of all row units. It may be necessary to readjust some rows to obtain uniform operation. Available depth adjustment range is approximately 1/2" to 3 1/2".

WARNING: Never work under the planter while in raised position without using safety lockup devices.

D020705102

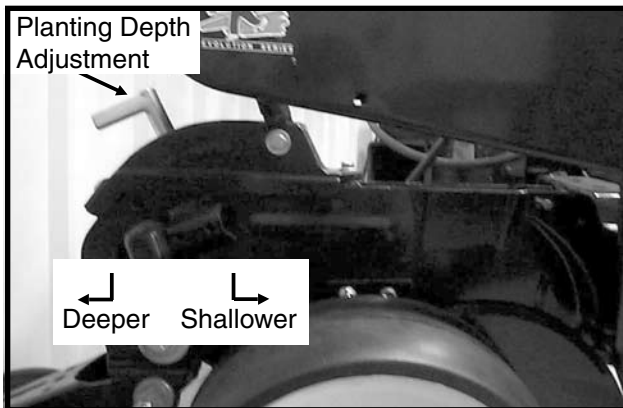

"V" CLOSING WHEEL ADJUSTMENT (RUBBER AND CAST IRON)

WARNING: Raise planter and install safety lockup devices before making closing wheel adjustments.

After adjusting planting depth, check the operation of the "V" closing wheels. The "V" closing wheels should have enough down pressure to close the seed trench and ensure good soil to seed contact. To increase spring pressure on the closing wheels, move the 5-position quick adjustable down force lever located on the top of the closing wheel arm to the rear. Moving the lever forward decreases spring tension.

Adjust all row units to a similar setting.

LF212299-15

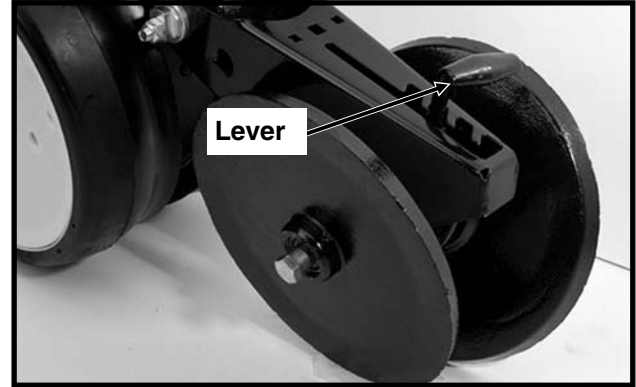

Light soil usually requires less down force at average depth (approximately 2") while heavy soil requires increased down force.

Eccentric bushings in the wheel arm stop allow for lateral adjustment of the "V" closing wheel assembly. Using a 3/4" wrench, loosen the hardware which attaches the closing wheel arm to the wheel arm stop. Using another 3/4" wrench turn the eccentric bushings until the **closing wheels are aligned with the seed trench**. Tighten hardware.

LF2122299-15

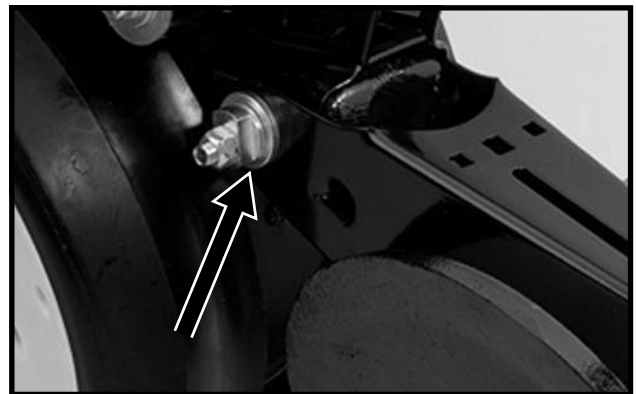

The closing wheels can be installed in two locations either "offset" (to improve residue flow) or "directly" opposite. If set "directly" opposite, the forward installation holes should be used.

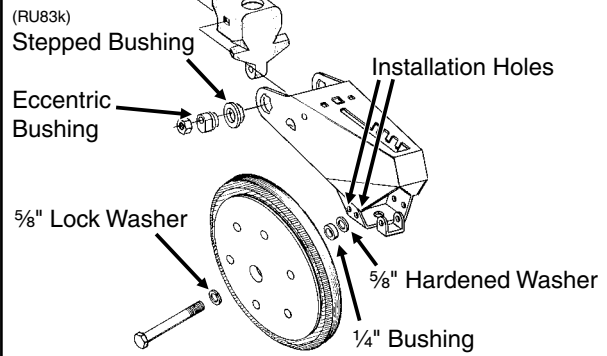

ROW UNIT OPERATION

CLOSING WHEEL SHIELD (RUBBER AND CAST IRON "V" CLOSING WHEELS)

D11090208a

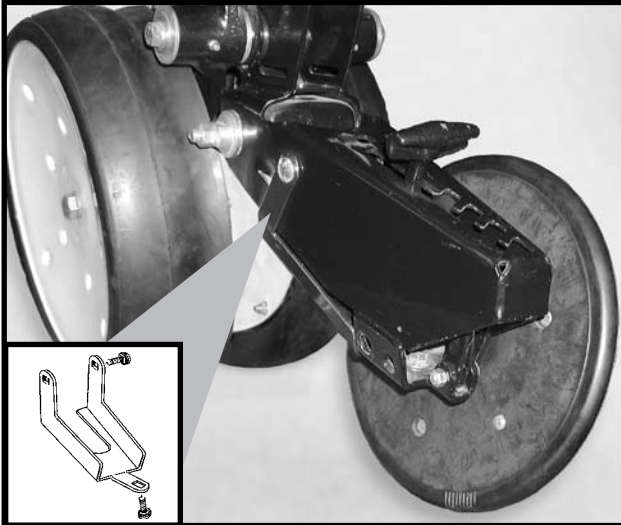

Shown With Closing Wheel Removed For Visual Clarity

The optional closing wheel shield is designed to be installed onto the underside of the closing wheel arm to help prevent root balls and stalks from plugging the closing wheels.

COVERING DISCS / SINGLE PRESS WHEEL ADJUSTMENT



WARNING: Raise planter and install safety lockup devices before making covering discs/single press wheel adjustments.

72359-31



After adjusting planting depth, check the operation of the covering discs/single press wheels.

Initial press wheel down force setting should be with 2 1/2" between mounting arm tab and locking nut. To adjust down force spring, loosen 1/2" locking nut and turn adjusting bolt in to increase down force or out to decrease down force. Tighten locking nut against spring plug. Adjust all row units to a similar setting.

RH993(PLTR12)

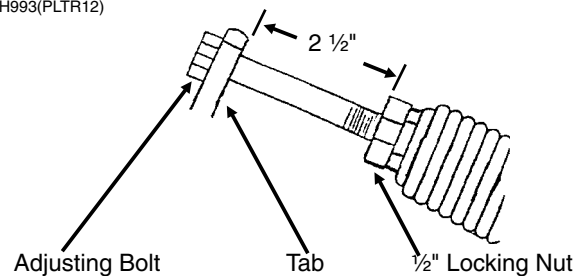

ROW UNIT OPERATION

Eccentric bushings in the wheel arm stop allow for lateral adjustment of the covering discs/single press wheel assembly. Using a 3/4" wrench, loosen the hardware which attaches the assembly to the wheel arm stop. Using another 3/4" wrench, turn the eccentric bushings until the press wheel is aligned with the seed trench.

(RU94b)

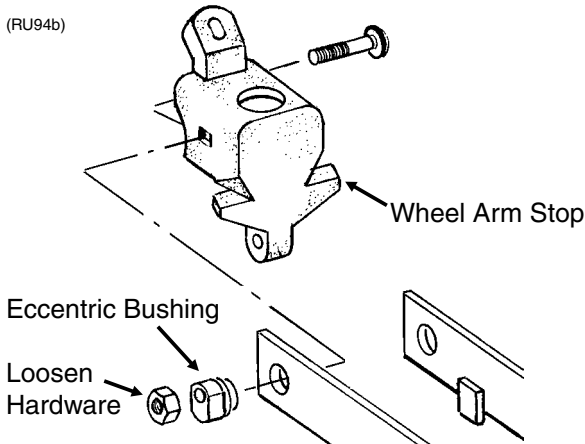

Two sets of holes in the mounting arm allow the covering discs to be located for staggered or side-by-side operation as desired.

72359-35

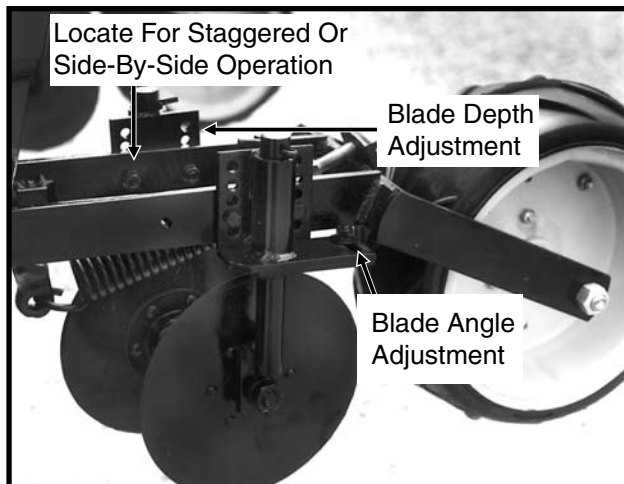

Five sets of holes in each disc bracket allow for 1/2" incremental blade depth adjustment.

Slotted holes in the disc mount and bracket allow for 0° - 15° blade angle adjustment.

Adjust covering discs on all row units to similar settings.

DRAG CLOSING ATTACHMENT

LF212299-18

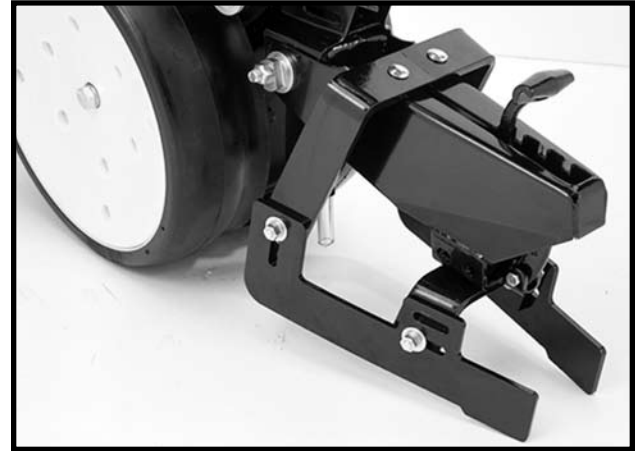

The drag closing attachment is designed to pull loose soil over the seed trench.

Front and rear adjustment is made using the slotted holes in the blades. Adjust all rows the same.

NOTE: Use of a seed firming wheel or other seed firming device is recommended with the drag closing attachment.



WARNING: Raise planter and install safety lockup devices before making drag closing attachment adjustments.

(RU90d)

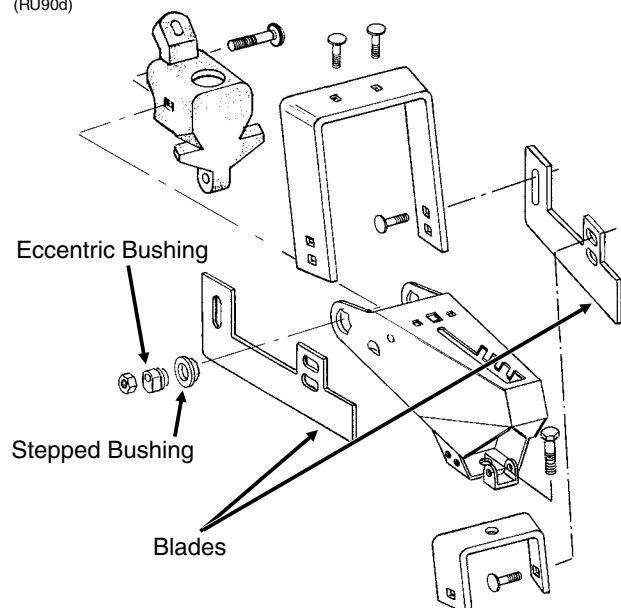

Eccentric bushings allow for lateral adjustment of the drag closing attachment. Using a 3/4" wrench, loosen the hardware which attaches the assembly to the wheel arm stop. Using another 3/4" wrench, turn the eccentric bushings until the drag closing attachment is aligned with the seed trench.

ROW UNIT OPERATION

SEED HOPPERS

(METR12)

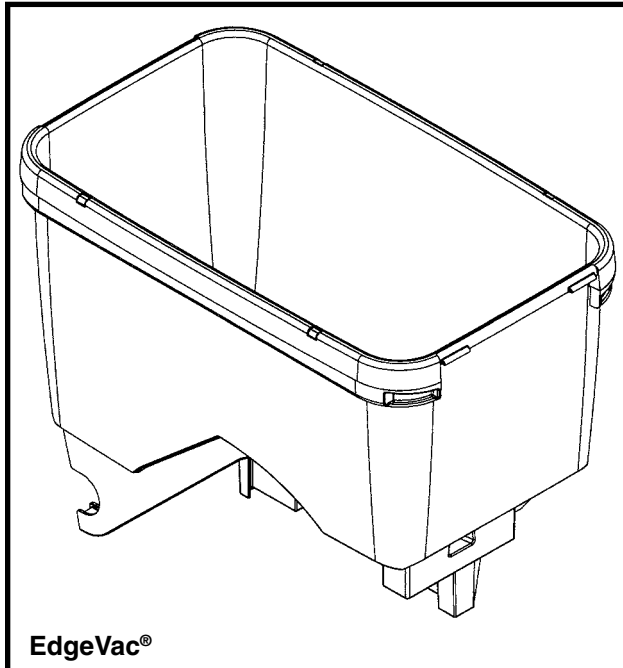

LF212199-7a



The capacity of each EdgeVac® seed hopper is 1.75 bushels and capacity of each Mechanical seed hopper is 1.9 bushels.

When filling the seed hopper use clean seed and make certain there are no foreign objects in the hopper. **Replace hopper lids after hoppers are filled to prevent the accumulation of dust or dirt in the seed meter which will cause premature wear.** See “EdgeVac® Seed Meter”, “Finger Pickup Seed Meter”, or “Brush-Type Seed Meter”. in Seed Meter Operation section.

Periodically empty the hoppers completely to remove any foreign material and to ensure proper seed meter operation. To empty hopper, disengage meter drive and hopper latch and lift hopper off the hopper support. See “Seed Meter Drive Release” in Row Unit Operation section.

ROW UNIT OPERATION

ROW UNIT EXTENSION BRACKETS

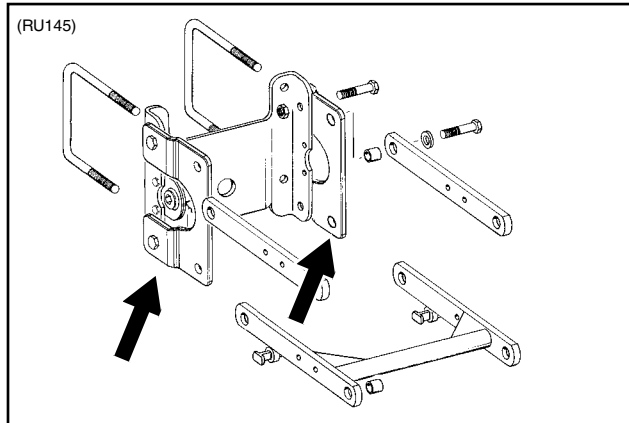

Row unit extension brackets are required on the six center row units of the Model 3660 planter. The brackets extend the row units rearward 4" to provide the required clearance for coulter mounted residue wheels.

SEED METER DRIVE RELEASE

The seed meter drive is equipped with a clutch release mechanism that allows the drive to be disengaged from the seed metering unit for removal of the seed hopper. Disconnecting the drive allows the operator to check granular chemical application rates without dropping seed. It also allows one or more of the rows to be disconnected when finishing fields.

D011006101

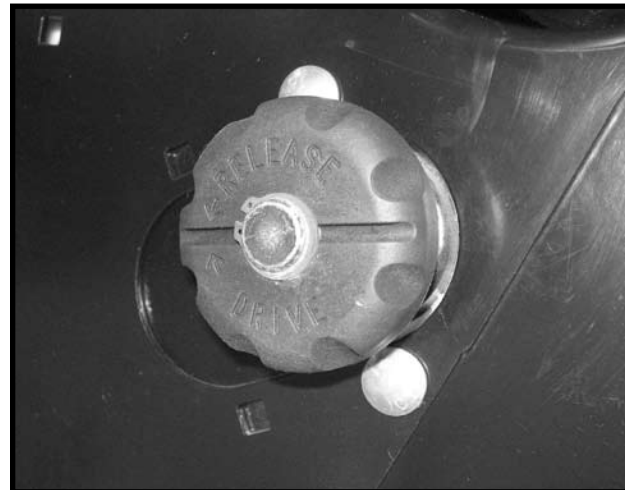

To disengage the drive, turn the knob $\frac{1}{4}$ turn counterclockwise. To engage the drive, turn the knob $\frac{1}{4}$ turn clockwise.

ROW UNIT OPERATION

QUICK ADJUSTABLE DOWN FORCE SPRINGS OPTION

Quick adjustable down force springs are designed to increase penetration in hard soil and keep the row unit from bouncing in rough field conditions.

Two springs per row, one on the L.H. parallel arms and one on the R.H. parallel arms, are used unless equipped with row unit mounted no till coulters. Four springs per row are used with row unit mounted no till coulters.

D06300305



Two Springs Per Row (Dual)

D07010301

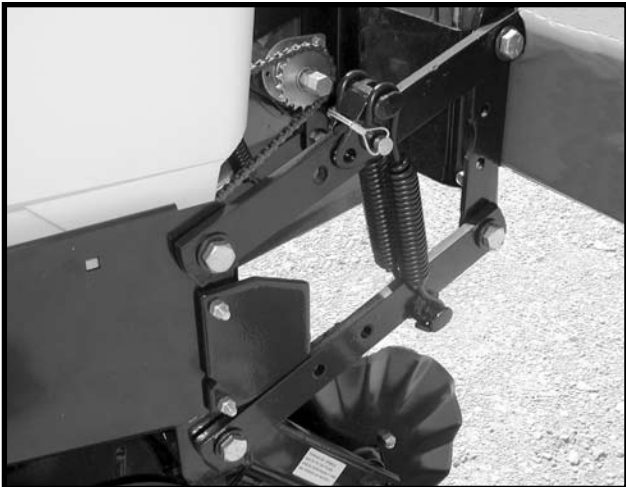

**Four Springs Per Row (Quad)
(Used Only In Conjunction With Row Unit Mounted
No Till Coulters)**

NOTE: Four springs per row are to be used with row unit mounted no till coulters only.

There are four positions for spring tension adjustment. Position 1 allows for minimum down pressure and position 4 for maximum down pressure.

L0096(PLTR27e)

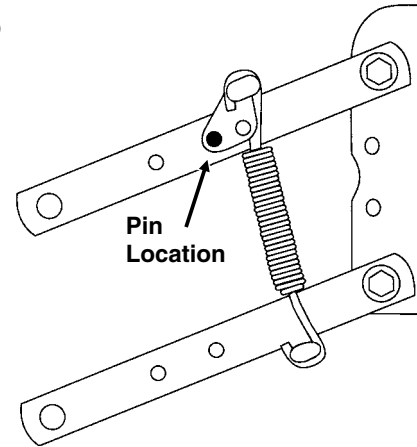

Position 1 (Minimum)

(PLTR28e)

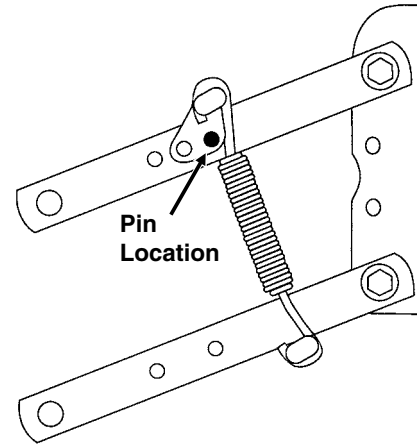

Position 2

(PLTR29e)

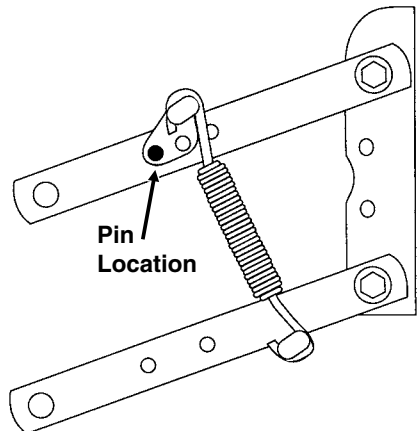

Position 3

ROW UNIT OPERATION

(PLTR30e)

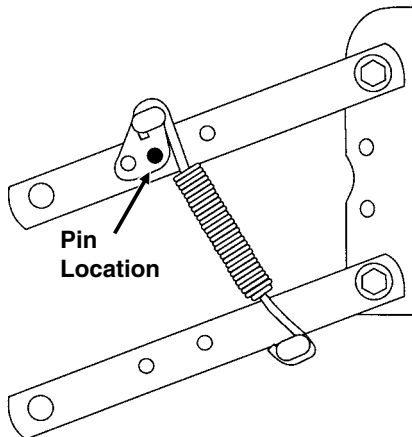

Position 4 (Maximum)

To adjust spring tension, raise planter and remove spring mount pin at top of spring. Slide mount to desired position and install pin.

NOTE: It is necessary for the operator to adjust springs according to field conditions. If springs are adjusted for too much down pressure for field conditions, it is possible for the row units to lift the planter to the extent that the drive wheels do not make sufficient contact. Too much down pressure in soft field conditions can cause the row unit to run too deep.



WARNING: Always install safety lockup devices or lower machine to the ground before working under or around the machine.

IMPORTANT: Springs must always be installed with open side of spring hooks toward the seed hoppers to prevent binding on spring mount adjustment pins.

ROW UNIT OPERATION

PNEUMATIC DOWN PRESSURE PACKAGE OPTION

With pneumatic down pressure option, the operator can vary row unit down pressure on-the-go as field conditions change. A cab-mounted digital readout displays down force (lbs.) applied. A planter-mounted 12 VDC air compressor, with 3 gallon capacity air tank, supplies air for the down pressure system.

Packages also include upper and lower air spring mounting castings for pull row units (fore and aft air spring mounting castings for push row units), 150 psi rated air springs, 3/8" O.D. nylon hoses, dual solenoid air valve and stainless steel, 160 psi, 2" liquid-filled gauge and planter wiring harness.

Pneumatic down pressure row unit extension brackets are required in some applications.

(PNE01e)

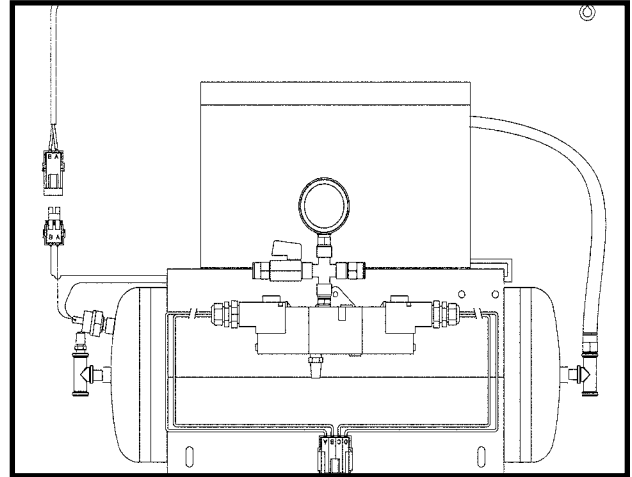

Air Compressor With Dual Solenoid Assembly

(PNE07)

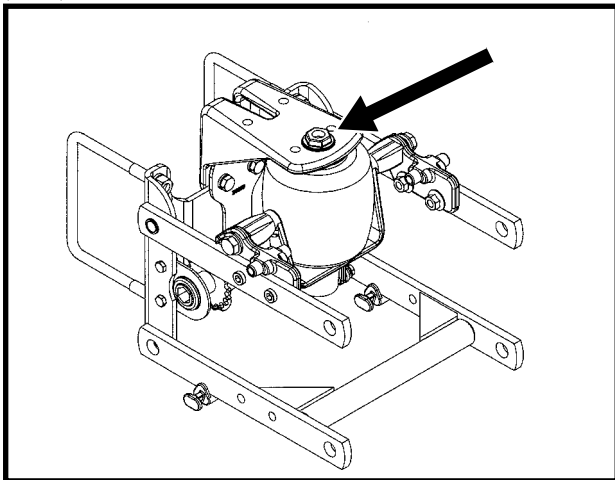

Pull Row Unit Air Spring

NOTE: Shoulder nut(s) should be torqued to 350 in. lbs. Refer to page 9-1 for additional torque values.

(PNE09)

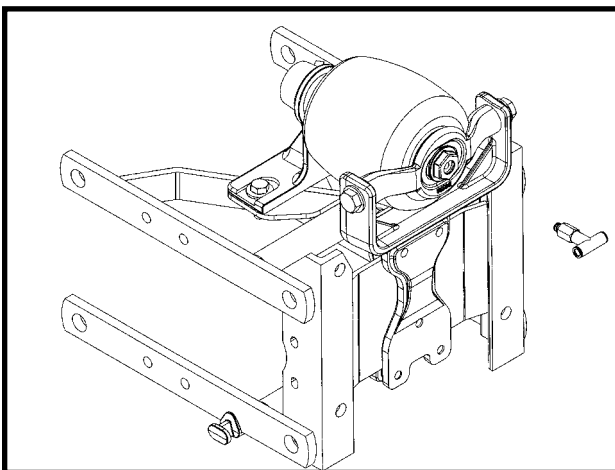

Push Row Unit Air Spring

(A14012)

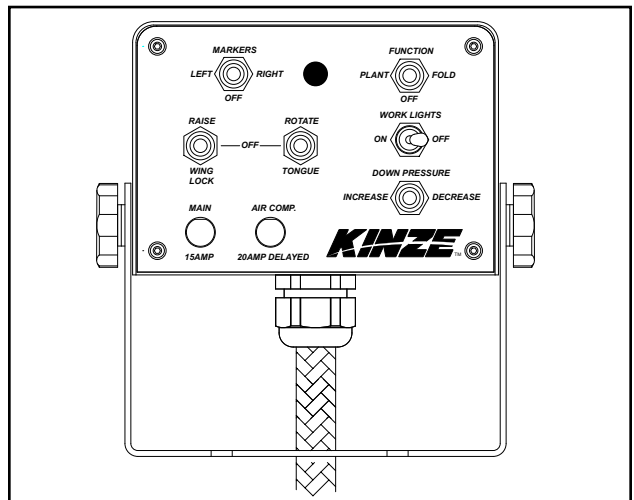

Control Console Assembly

ROW UNIT OPERATION

NOTE: If additional down pressure is needed with the Pneumatic Down Pressure Package, assist springs are available through your KINZE® dealer. One spring is installed on the outer side of the parallel arms on each side of the row unit as shown below.

D11280753a

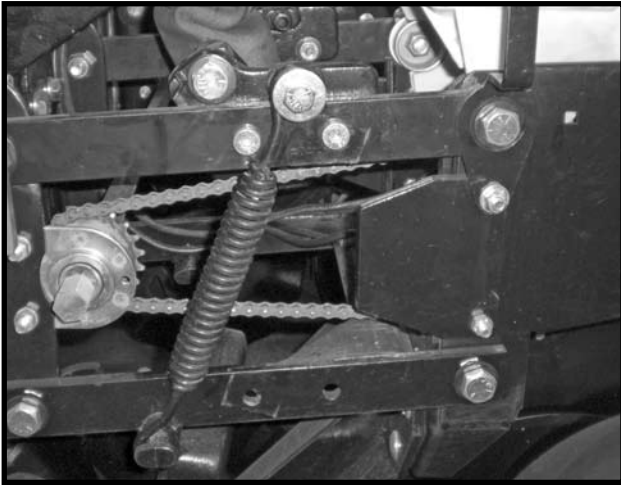

Pull Row Unit Assist Springs

D11280749a

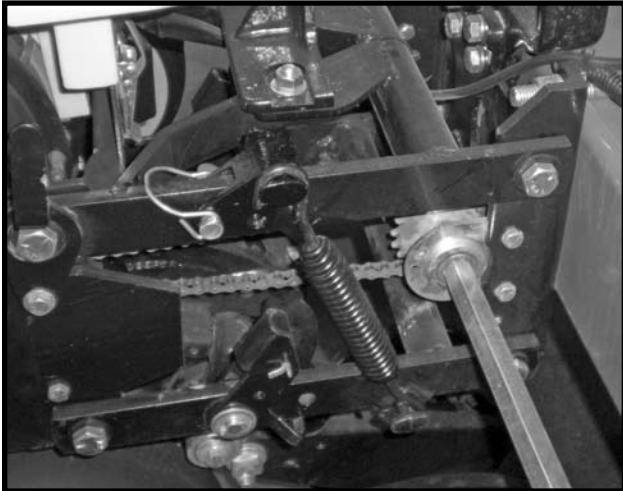

Push Row Unit Assist Springs

FIELD OPERATION

NOTE: For the most accurate adjustment, adjust down pressure with planter lowered and row openers in the ground. Pressure can be adjusted from tractor using the control console, or at planter using the manual control valves.

(A14012)

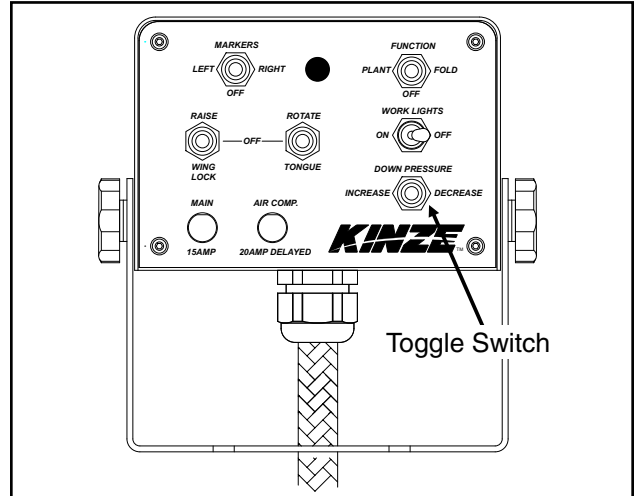

To adjust down pressure from cab:

To INCREASE pressure, push toggle switch left.

To DECREASE pressure, push toggle switch right.

To adjust down pressure from planter:

To INCREASE pressure, press and hold button on solenoid as shown below.

To DECREASE pressure, press and hold button on solenoid as shown below.

The readout value on the air pressure gauge is NOT the down pressure force value. To calculate the force value, multiply the air pressure (psi) by four (4).

D112907100

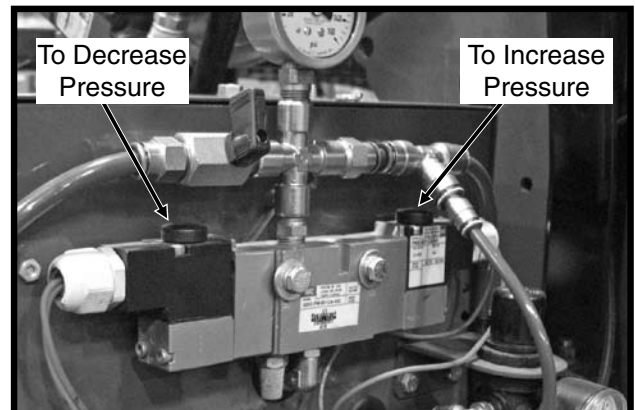

ROW UNIT OPERATION



WARNING: Always install all safety lockup devices or lower planter to the ground before working under or around the machine.

D112907100

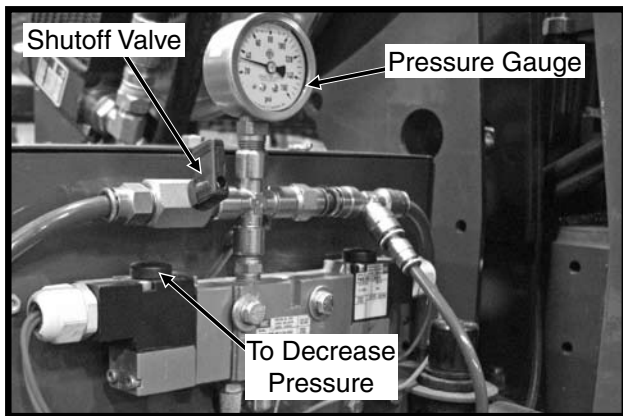

To lock up push row units equipped with pneumatic down pressure springs:

- STEP 1** Disconnect electric power supply to compressor.
- STEP 2** Press and hold button on solenoid until pressure gauge reads zero.
- STEP 3** Lock up units. See “Interplant Push Unit Lockup” for instructions.
- STEP 4** Turn the shutoff valve handle perpendicular to valve body. This turns off air supply to the push row units.

NOTE: If control console is ON and the hydraulic down force is not set to zero, compressor will start when electric power supply is reconnected.

- STEP 5** Reconnect electric power supply to compressor.

ROW UNIT OPERATION

FRAME MOUNTED COULTER

LF083002101

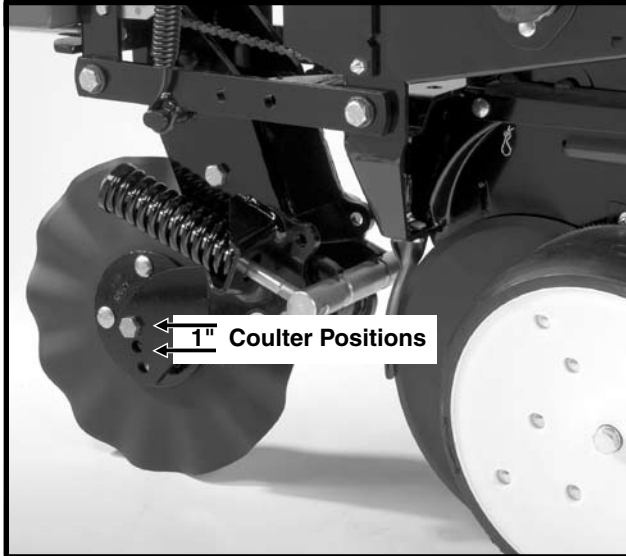

Frame mounted coulters with 1" bubbled, 1" fluted (8 flutes) or ¾" fluted (13 flutes) blades may be used on pull row units only. (Not compatible with push row units.)

The frame mounted coulters is designed to apply necessary spring down pressure on the coulters for maximum penetration while exerting less shock load on the row unit.

The initial location of the coulters blade is in the top hole. The blade can be relocated to one of the lower two holes (1" increments) as wear occurs or if deeper operation of the blade is desired.

LF083002101

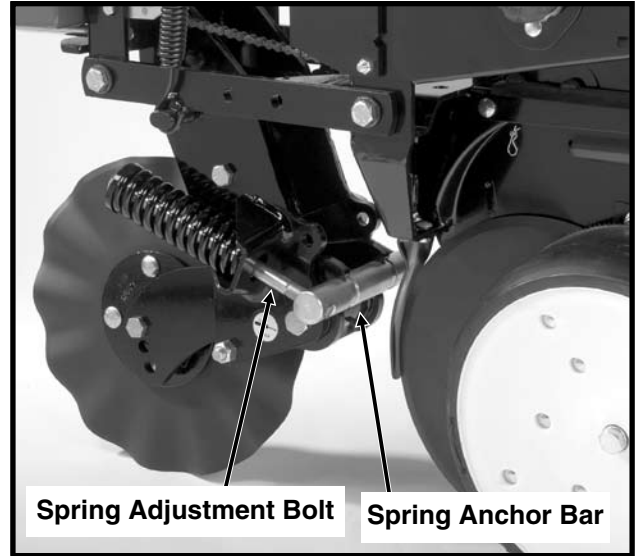

DOWN PRESSURE ADJUSTMENT

Down force adjustment is made by tightening or loosening the two spring adjustment bolts. With the planter in raised position, turn the bolts clockwise to increase down pressure or counterclockwise to decrease down force. Set both springs the same.

Down force on the blade is shown below in lbs.

End Of Spring Adjustment Bolt Flush With Spring Anchor Bar (Shown Above)	End Of Spring Adjustment Bolt Extended ½" Through Spring Anchor Bar	All Threads Used (Maximum)
275 lbs.	400 lbs.	500 lbs.

NOTE: Avoid setting down pressure higher than is required for consistent soil penetration. Excessive pressure will increase the chances of damage to coulters components when the coulters strikes an obstacle.

ROW UNIT OPERATION

RESIDUE WHEELS (For Use With Frame Mounted Coulter)

The residue wheels for use with the frame mounted coulter may be used on pull row units only.

The residue wheels are attached to the frame mounted coulter with two cap screws and sleeves allowing the unit to free-float. A 2-position spindle bolt mounting allows the tined wheels to be mounted interlocked or staggered. Depth adjustment is made using a spring-loaded cam and pin with 11 positions in $\frac{1}{4}$ " increments. A high point on the cam allows the wheels to be locked up so they do not contact the ground. A weed guard, located on the inboard side of each wheel, aids in the prevention of weed wrap which can cause premature bearing failure.

(RU135m)

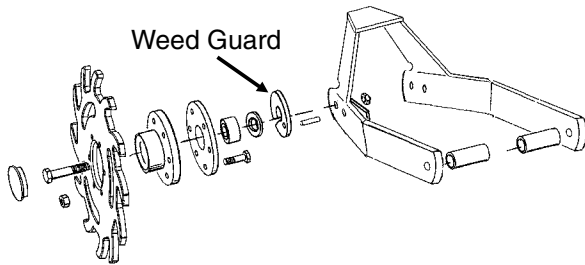

NOTE: Opening in weed guard must point down.

IMPORTANT: The forward mounting positions of the tined wheels can not be used on the four rows behind the axle on the 3600 machine due to inadequate clearance.

ROW UNIT MOUNTED DISC FURROWER

The row unit mounted disc furrower is for use on pull row units only (not compatible with Interplant® push row units). The disc furrower may be equipped with either 12" solid blades or 12" notched blades.

Disc furrowers are used to clear crop residue, dirt clods and dry soil from in front of the row units for a clean and smooth seed bed. Notched blades are used for heavier residue conditions. The notched blades cut crop residue and move it aside to prevent plugging or pushing.

LF212299-22

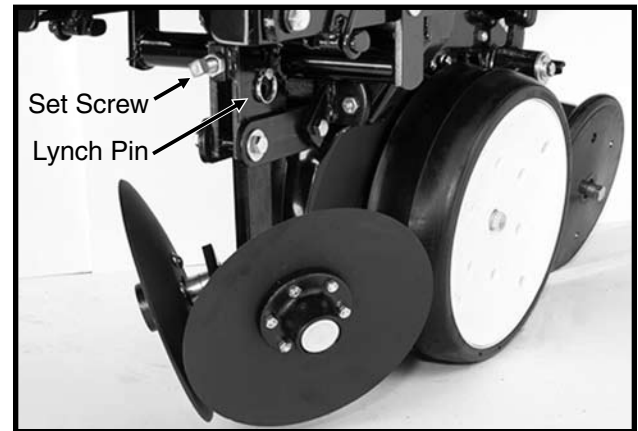

Vertical adjustment in $\frac{1}{3}$ " increments is possible by removing the lynch pin which secures the vertical support arm and moving the support arm up or down as required. Reinstall lynch pin. Finer adjustment can be attained by removing the lynch pin and using the $\frac{5}{8}$ " x $2 \frac{1}{4}$ " set screw to clamp the support arm in the required position.

(RU98e)

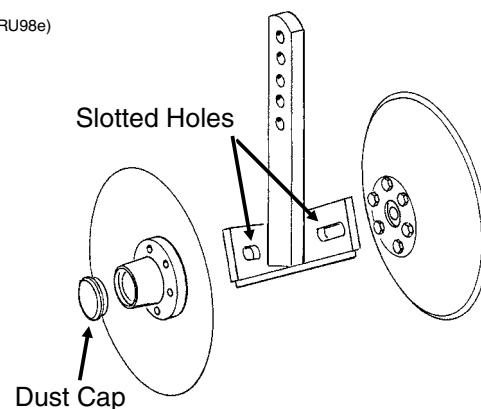

Slotted holes in the support arm where the blades are mounted allow fore and aft adjustment of the disc blades. Blades can be adjusted so the front edges meet or one blade can be moved to the rear and the other to the front of the slot so the cutting edge of one blade overlaps the edge of the other blade. The dust cap must be removed to make these adjustments.

ROW UNIT OPERATION

ROW UNIT MOUNTED BED LEVELER

LF212299-25a

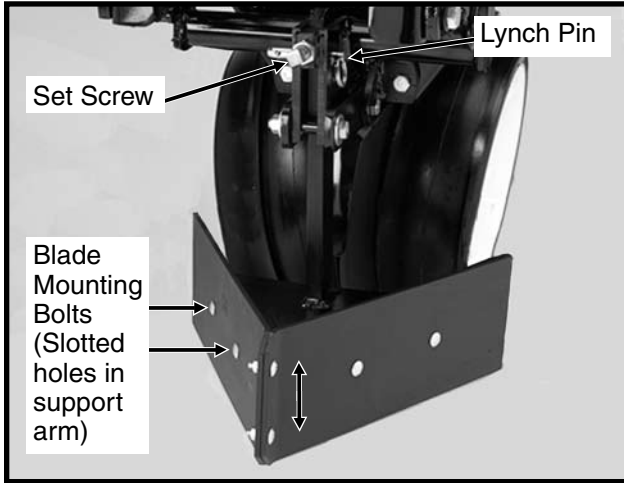

Row unit mounted bed levelers may be used on pull row units only. They are not compatible with push row units.

Vertical adjustment in $\frac{1}{3}$ " increments is possible by removing the lynch pin which secures the vertical support arm and moving the support arm up or down as required. Re-install lynch pin. Finer adjustment can be attained by removing the lynch pin and using the $\frac{5}{8}$ " x $2 \frac{1}{4}$ " set screw to clamp the support arm in the required position.

Slotted holes in the support arm where the blades are mounted allow tilting of the blades. The blades can be tilted up or down at the front for desired adjustment.

NOTE: The row unit mounted bed leveler is not compatible with row spacings less than 36".

ROW UNIT MOUNTED RESIDUE WHEEL

The row unit mounted residue wheel may be used on pull row units and push row units.

(A12685)

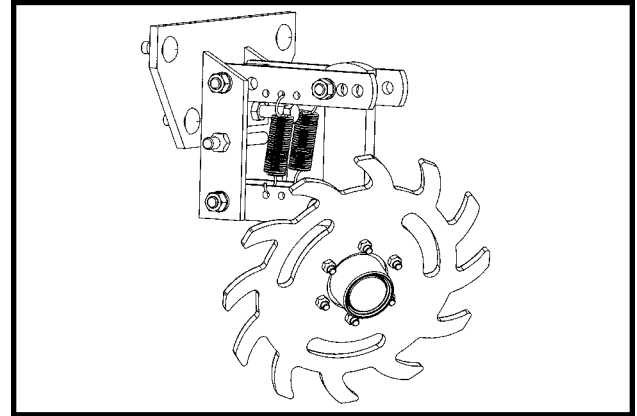

ROW UNIT OPERATION

Two adjustable springs on the parallel links on each residue wheel allow for down force adjustment. Position 1 as shown below provides minimum down pressure and position 3 maximum down pressure.

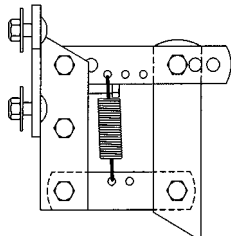

Position 1 (Minimum) (PLTR31a)

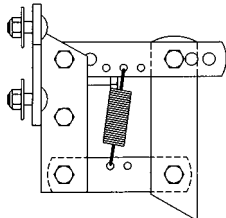

Position 2 (PLTR32a)

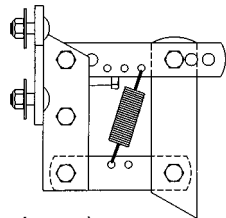

Position 3 (Maximum) (PLTR33a)

For additional uplift or float, position springs as shown below.

(PLTR34a)

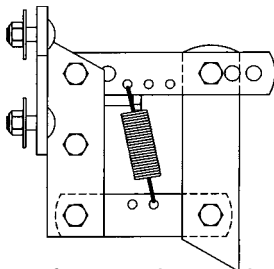

To adjust down force springs, raise the row unit out of the ground and reposition springs as shown for the desired down pressure.

D101701112

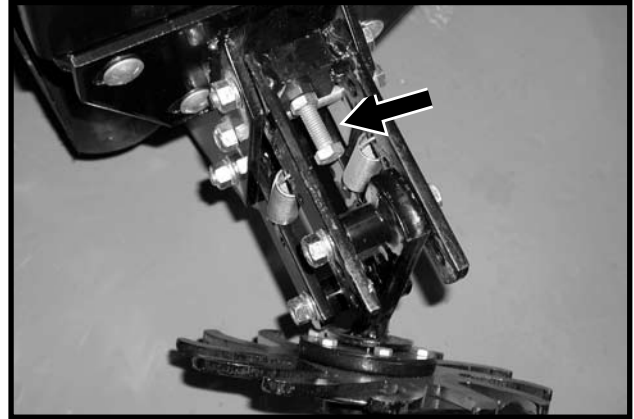

A full threaded bolt and jam nut located on the upper link allows maximum depth to be set for loose soil conditions. Initial setting should be 1 3/4" above the depth of the row unit double disc opener.

Three holes in the upper link allow for wheel angle adjustment. With the wheel mount in the most vertical position, using the rear hole in the upper link, the residue wheel is most aggressive. Moving the wheel mount to one of the forward holes reduces the aggressiveness of the wheel for use in mulch till applications where the soil is loose.

D101701202

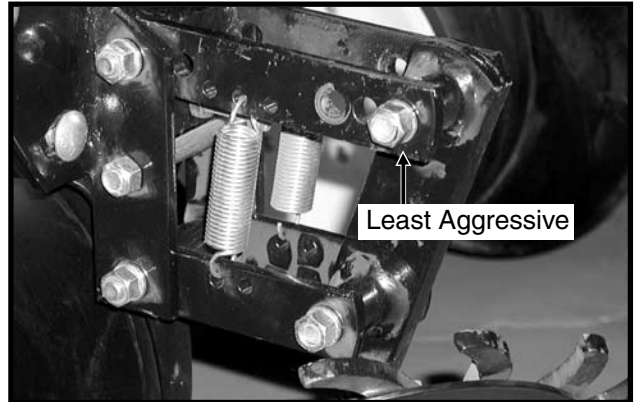

To lock the residue wheel up out of the ground, remove the 1/2" x 5" lockup bolt, raise the residue wheel and install bolt.

D011701203

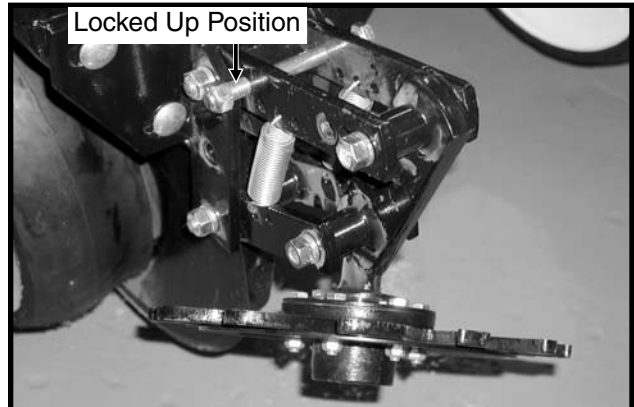

ROW UNIT OPERATION

ROW UNIT MOUNTED NO TILL COULTER

D05170706a



Row unit mounted no till coulters with 1" bubbled, 1" fluted (8 flutes) or 3/4" fluted (13 flutes) blades may be used on pull row units and push row units. (3/4" fluted shown)

Four quick adjustable down force springs are required per row when using row unit mounted no till coulters. See "Quick Adjustable Down Force Springs".

For proper operation, the coulters blade should be aligned in relation to the row unit double disc openers. The coulters assembly can be adjusted by loosening the four attaching bolts, moving coulters arm to align and tightening the four attaching bolts.

The coulters blade can be adjusted to one of four 1/2" incremental settings in the forked arm. Initial location of the coulters is in the top hole. As the coulters blade wears, the blade should be adjusted downward to one of the three lower settings to maintain the coulters blade at or slightly below the opener discs. In very hard soil conditions such as compacted wheel tracks, opener penetration and cutting of surface residue may be improved by adjusting the coulters to operate below the depth of the double disc opener blades.

Operating depth can be checked by setting the planter down on a level concrete floor and checking the relationship between the coulters blade and row unit opener blade. Make sure the planter is level and coulters is square with the planter frame and aligned with the row unit disc opener.

NOTE: Torque 5/8" spindle bolts to 120 ft. lbs.

COULTER MOUNTED RESIDUE WHEELS

D05170708a



Coulters mounted residue wheels are designed for use on pull row units and push row units. Row unit extension brackets are required on the four center pull row units if the planter is equipped with coulters mounted residue wheels.

The coulters mounted residue wheels are attached to the row unit mounted no till coulters with one cap screw and sleeve allowing the unit to free-float. A 2-position spindle bolt mounting allows the tined wheels to be mounted interlocked or staggered. Depth adjustment is made using a spring-loaded cam and pin with 11 positions in 1/4" increments. A high point on the cam allows the wheels to be locked up so they do not contact the ground. A weed guard, located on the inboard side of each wheel, aids in the prevention of weed wrap which can cause premature bearing failure.

(RU153a)

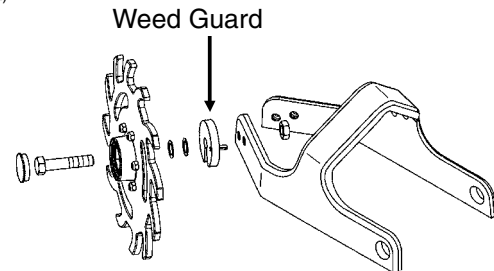

NOTE: Opening in weed guard must point down.

ROW UNIT OPERATION

GRANULAR CHEMICAL HOPPER AND DRIVE

LF212299-6



The granular chemical hopper has a 1.4 cubic feet capacity.

Be sure no foreign objects get into the hopper when it is being filled. Replace the hopper lids after filling the hoppers to prevent the accumulation of dirt and moisture.

The metering gate located on the bottom of the hopper regulates the application rate. See “Dry Insecticide And Dry Herbicide Application Rate Charts” in this manual. Calibrate using the chemical manufacturers’ instructions.



WARNING: Agricultural chemicals can be dangerous. Improper selection or use can seriously injure persons, animals, plants, soil or other property. BE SAFE: Select the right chemical for the job. Handle it with care. Follow the instructions on the container label and of the equipment manufacturer.

The granular chemical clutch drive coupler and meter shaft can be disengaged and engaged by turning the throwout knob located at the rear of the hopper support panel. To engage the drive, turn the knob ¼ turn clockwise. To disengage the drive, turn the knob ¼ turn counterclockwise. Slotted holes in the hopper support panel and clutch housing allow for alignment adjustment between the clutch drive coupler and meter shaft.

LF212299-4

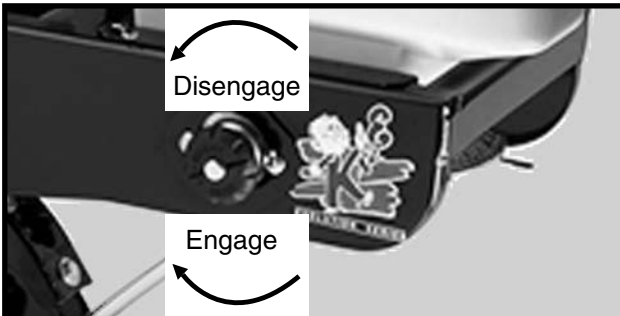

[Return to Table of Contents](#)

GRANUALR CHEMICAL BANDING OPTIONS

Granular chemical banding options allow 4 ½" slope-compensating banding, straight drop in-furrow placement or 14" rear banding.

NOTE: The granular chemical rear bander is not compatible with the covering discs/single press wheel option.

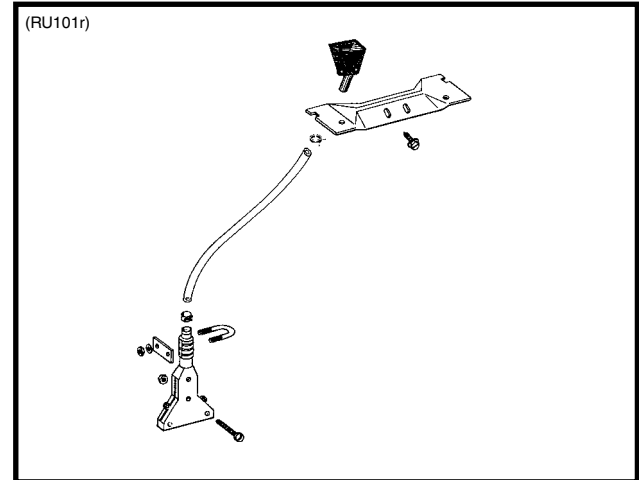

4 ¼" Slope-Compensating Bander

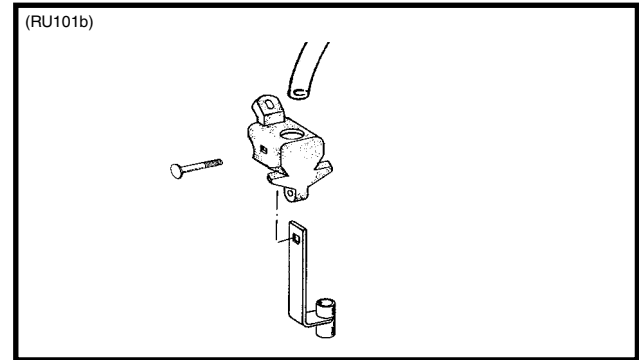

Straight Drop In-Furrow Placement

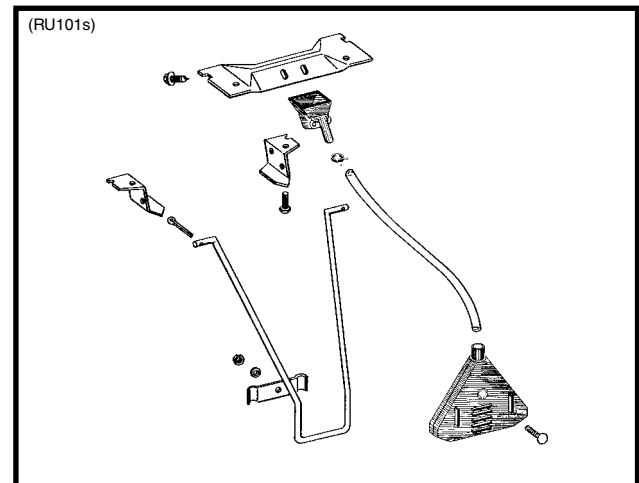

ROW UNIT OPERATION

GRANULAR CHEMICAL BANDER SHIELD

The optional granular chemical bander shield is designed to be installed onto the underside of the wheel arm stop to shield crop residue from lodging in the granular chemical bander.

(RU83m)

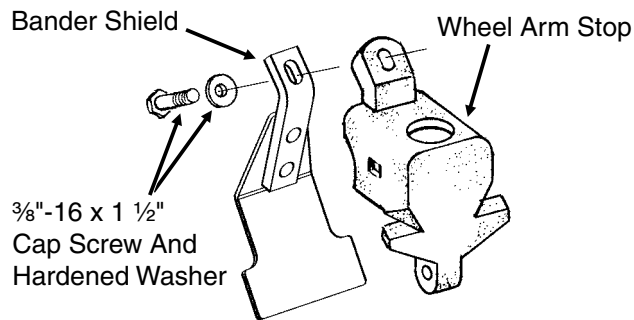

SPRING TOOTH INCORPORATOR

The spring tooth incorporator smoothes the soil behind the row unit and incorporates granular chemicals. The two mounting chains on each spring tooth incorporator should be adjusted so there is approximately $\frac{1}{8}$ " slack in the chain when the unit is lowered to planting position.

NOTE: The spring tooth incorporator is not compatible with the covering discs/single press wheel option.

LF212299-26

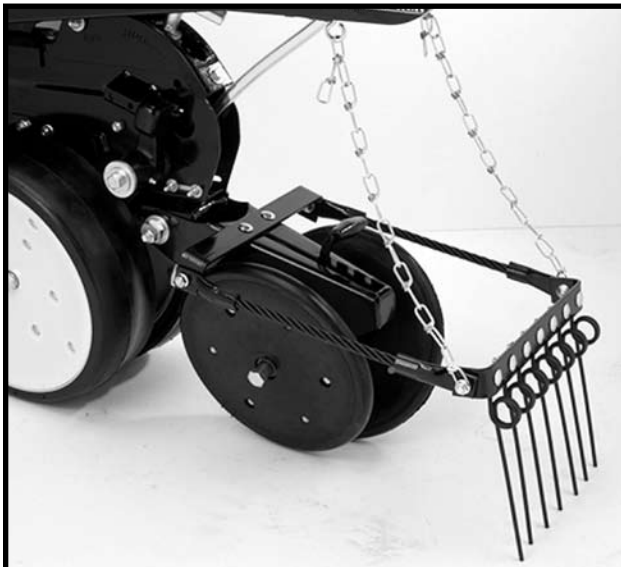

ROW UNIT OPERATION

INTERPLANT® PUSH ROW UNIT LOCKUPS

Push row unit lockups are designed to allow the push row units to be locked in the raised position.



WARNING: Always install all safety lockup devices or lower planter to the ground before working under or around the machine.

D062603106

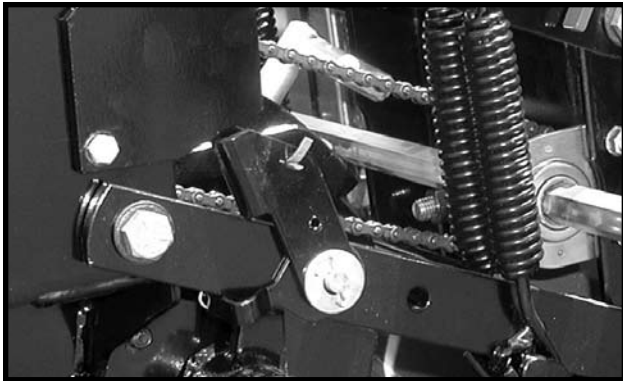

Push Row Unit Locked In Raised Position

D062603103

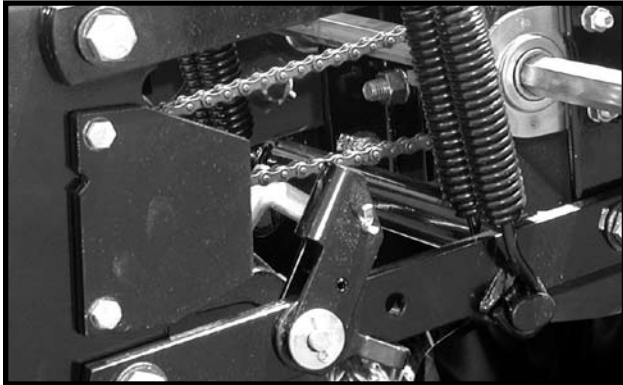

Lockup Released For Field Operation

D062603106a

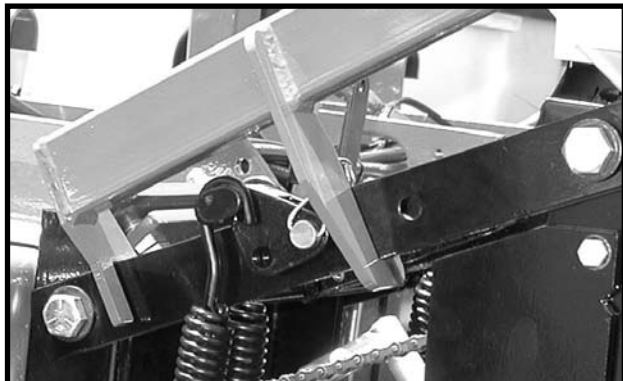

Lift Lever Positioned To Lift Push Row Unit

To lock in raised position:

1. Set row unit down pressure springs to minimum setting.
2. Lower the planter to the planting position.
3. Empty seed hoppers.
4. On each push row unit lockup, flip the spring tab forward.

D060499108

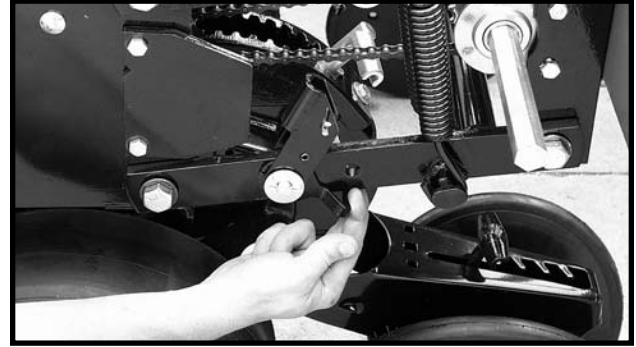

5. Using the lift lever, raise the push row unit to allow the spring loaded lockups to snap into locked position under the row unit stops.
6. Repeat Steps 4 and 5 on remaining push row units.

To release lockups:

1. Lower the planter to the planting position.
2. On each push row unit lockup, flip the spring tab rearward.

D060499107

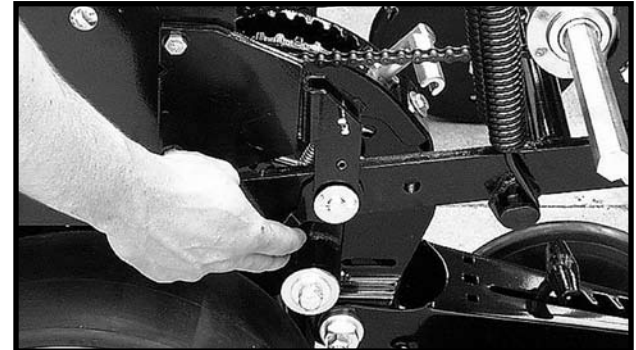

3. Using the lift lever, raise the push row unit to allow the spring loaded lockups to snap out of locked position. Lower row unit to the ground.
4. Repeat Step 3 on remaining push row units.

D08220663

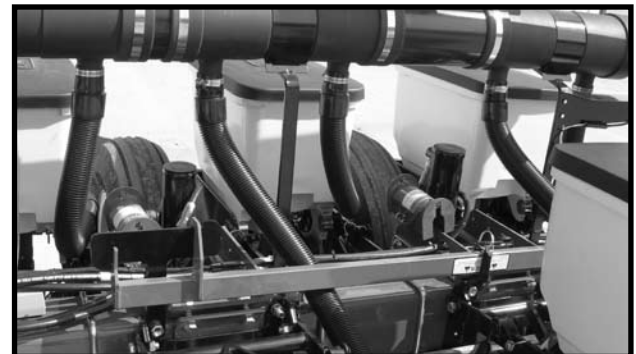

Lift Lever In Storage Location

ROW UNIT OPERATION

INTERPLANT® PUSH ROW UNIT CLUTCH

D021909258

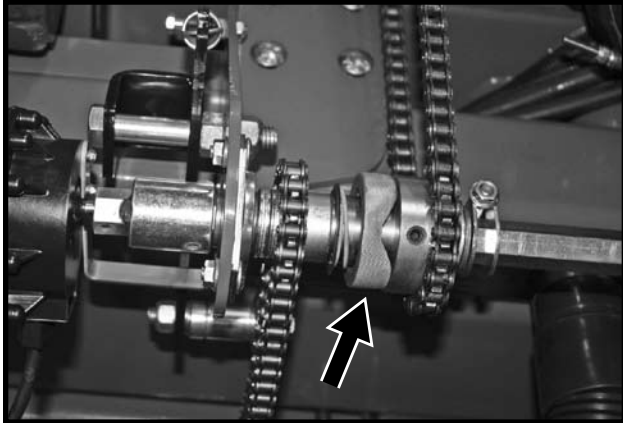

The push row unit clutch sprocket is designed to allow the push row unit drill shaft to be disengaged when only the pull row units are being used.

To disengage the push row unit drill shaft using the clutch sprocket, rotate the knurled collar on the clutch sprocket ¼ turn. Then using a 7/8" wrench on the drill shaft, rock the drill shaft slightly to take pressure off of the spring loaded pins in the clutch to allow the pins to "pop" out, disengaging the drive. To engage the drive, rotate the knurled collar ¼ turn and turn the drill shaft with a 7/8" wrench until the drive pins engage the drive sprocket.



WARNING: Always install all safety lockup devices or lower planter to the ground before working under or around the machine.

INTERPLANT® PUSH ROW UNIT VACUUM HOSE SHUTOFF

D12140617



D08220662

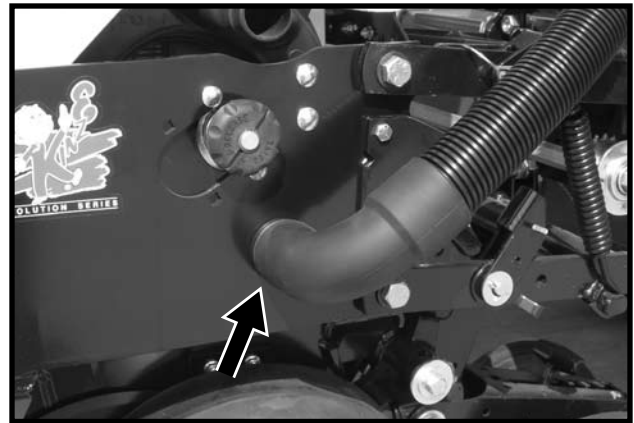

D030909210

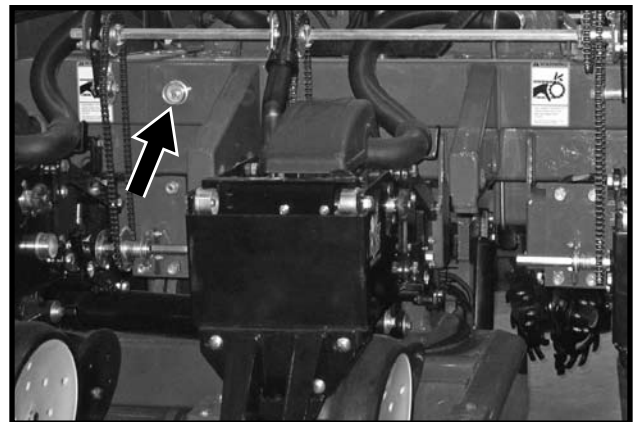

Storage plug for center push unit.

When the push row units are not being used, move the row unit end of the 2" vacuum hose on each push row unit to the storage mount located on the side of the shank as shown.



WARNING: Always install all safety lockup devices or lower machine to the ground before working under or around the machine.

ROW UNIT OPERATION

This page left blank intentionally.

SEED METER OPERATION

GENERAL PLANTING RATE INFORMATION (MECHANICAL SEED METERING)

The size and shape of seed may affect the planting rate.

Finger Pickup Corn Meter

Larger grades will generally plant more accurately at the high end of the ground speed range than smaller grades. Higher than optimum speeds may result in population rate increase or higher incidence of doubles, particularly with small seed. Medium round corn seed is most desirable for planting accuracy at optimum speed.

Finger Pickup Oil Sunflower Meter

Larger grades will generally plant more accurately at the high end of the ground speed range than smaller grades. Higher than optimum speeds may result in population rate increase or higher incidence of doubles, particularly with small seed. No. 3 and/or No. 4 size oil sunflower seeds are recommended for use in the finger pickup seed meter equipped with oil sunflower fingers. No. 1 and/or No. 2 size confectionery sunflower seeds are recommended for use in the finger pickup seed meter equipped with corn fingers.

NOTE: Seed additives, added to the seed in the hopper, may adversely affect performance of the finger pickup seed meter and accelerate wear. See “Finger Pickup Seed Meter” in the Row Unit Operation section.

Brush-Type Seed Meter (Soybean, Milo/Grain Sorghum, Acid-Delinted Cotton)

Rate charts are given in seeds per acre as well as seed spacing in inches rounded to the nearest tenth of an inch. Because of the large range in seed size, pounds per acre is not a suggested method of selecting transmission settings. When using smaller size seeds it may appear the pounds per acre is below what was expected and vice versa on large seed. To determine pounds per acre, use the formula given in “Determining Pounds Per Acre (Brush-Type Seed Meter)” in the “Checking Seed Population” section of this manual.

NOTE: Due to a multitude of variables, seed spacing can be adversely affected at speeds above 5.5 MPH.

SEED METER OPERATION

FINGER PICKUP SEED METER

Refer to the planting rate chart for recommended seed drive transmission sprocket combinations.

D12220401

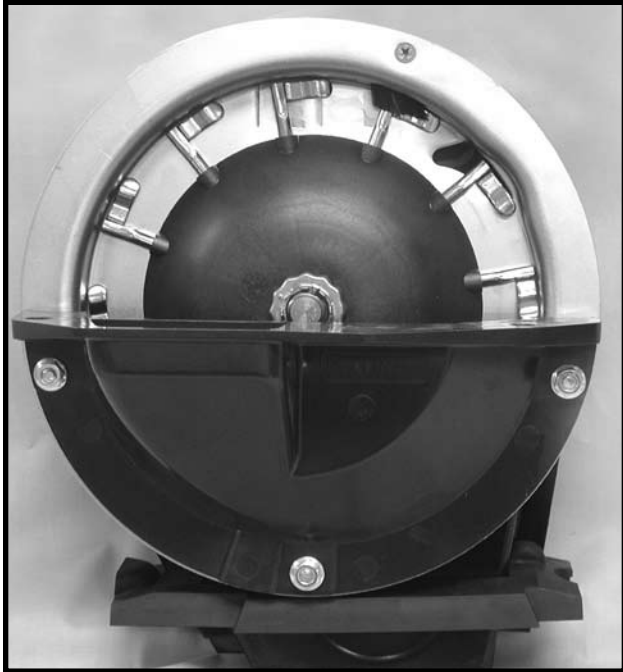

Shown With Corn Fingers Installed

The following seed fingers are available for use with the finger pickup seed meter:

(PLTR91/PLTR92/PLTR91a)

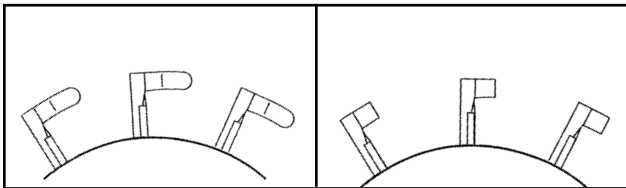

Corn Fingers

Oil Sunflower Fingers

No. 3 and/or No. 4 size oil sunflower seeds are recommended for use in the finger pickup seed meter equipped with oil sunflower fingers.

No. 1 and/or No. 2 size confectionery sunflower seeds are recommended for use in the finger pickup seed meter equipped with corn fingers.

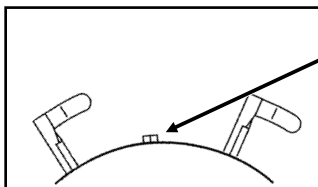

Half Rate Blank Finger

Blank fingers are used to replace alternate fingers in the finger wheel to reduce the planting rate by half while allowing the finger wheel to maintain a minimum of 40 RPM when planting low rates.

NOTE: Always check seed population in the field to ensure planting rates are correct.

Return to Table of Contents

NOTE: Powdered graphite is recommended for finger pickup seed meter lubrication to ensure efficient operation of the mechanism and to extend the life of its components. Mix one teaspoon of powdered graphite with the seed twice daily. Apply graphite on top of seed around the outer perimeter of the hopper as shown below. Graphite application frequency and volume may need to be increased if using additional seed treatments.

NOTE: Do NOT apply graphite only in the center of the hopper. It will filter too quickly through the seed and not distribute as evenly as desired.

D05230121b



NOTE: Follow manufacturer's recommendations when applying and mixing other seed treatments. If the additive is to be applied on top of the seed, apply around the outer perimeter of the hopper as with graphite.

See "General Planting Rate Information", "Finger Pickup Seed Meter Troubleshooting" and "Finger Pickup Seed Meter Inspection/Adjustment" for additional information.

CLEANOUT

To maintain genetic purity, thorough seed meter cleanout is important.

To clean the seed meter, disengage the seed drive and remove the seed hopper and meter. Dump the seed from the right rear corner of the hopper into a container. Turn the seed drive several times. Invert hopper to dump seed again. Shake the hopper and listen for any remaining seed. Turn seed drive and shake and dump hopper until all seed is removed.

SEED METER OPERATION

BRUSH-TYPE SEED METER

D12220403

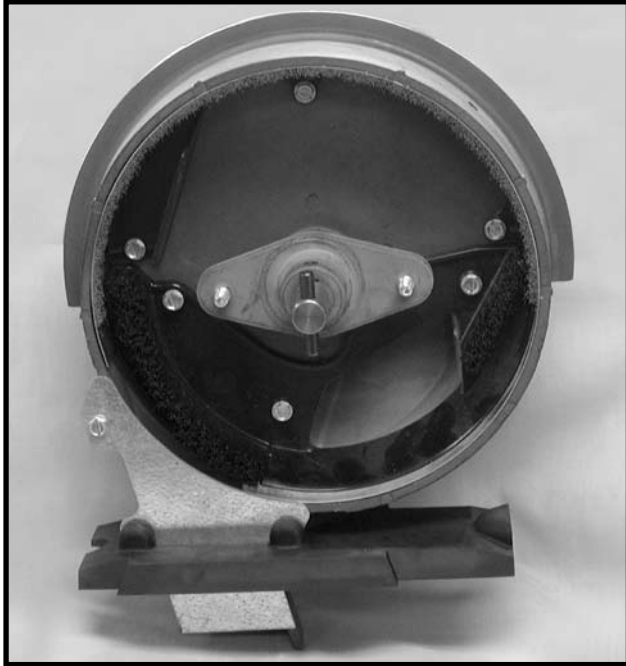

Shown Without Seed Disc Installed

60607-40a(PLTR13)

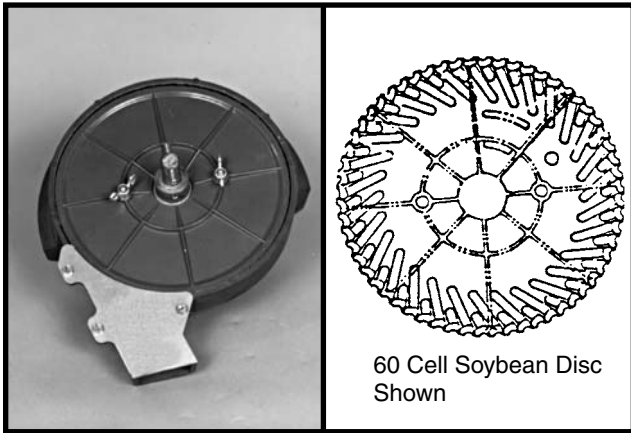

60 Cell Soybean Disc Shown

The following seed discs are available for use with the brush-type seed meter:

Soybean: 60 cells to meter seed sizes from 2200 to 4000 seeds per pound (Black color-coded).

(PLTR14)

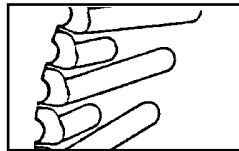

Specialty soybean: 48 cells to meter seed sizes from 1400 to 2200 seeds per pound (Dark blue color-coded).

(PLTR15)

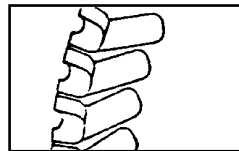

Small milo/grain sorghum: 30 cells to meter seed sizes from 14,000 to 20,000 seeds per pound (Red color-coded).

(PLTR16)

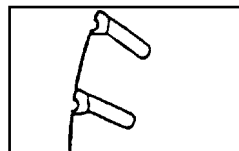

Large milo/grain sorghum:

30 cells to meter seed sizes from 10,000 to 16,000 seeds per pound (Light blue color-coded).

(PLTR17)

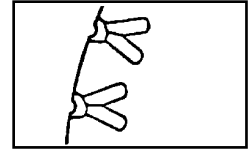

High-rate small milo/grain sorghum:

60 cells to meter seed sizes from 12,000 to 18,000 seeds per pound (Red color-coded). (PLTR18)



High-rate large milo/grain sorghum:

60 cells to meter seed sizes from 10,000 to 14,000 seeds per pound (Yellow color-coded). (PLTR19)

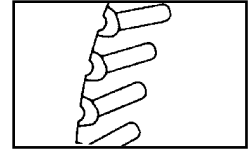

Cotton, acid-delinted: 30 cells to meter seed sizes from 4200 to 5200 seeds per pound (White color-coded).

(PLTR20)

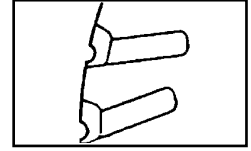

Large cotton, acid-delinted:

36 cells to meter seed sizes from 3800 to 4400 seeds per pound (Tan color-coded).

(PLTR21)

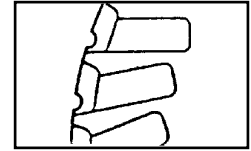

High-rate cotton, acid-delinted:

48 cells to meter seed sizes from 4200 to 5200 seeds per pound (Light green color-coded).

(PLTR22)

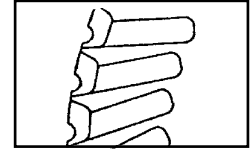

Hill-drop cotton, acid-delinted:

12 cells, 3 to 6 seeds/cell, to meter seed sizes from 4000 to 5200 seeds per pound (Brown color-coded). (PLTR23)

(PLTR23)

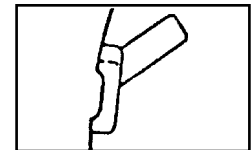

Small hill-drop cotton, acid-delinted:

12 cells, 3 to 6 seeds/cell, to meter seed sizes from 5000 to 6200 seeds per pound (Dark green color-coded).

(PLTR23)

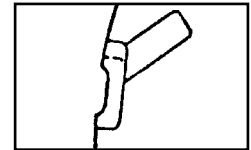

(RU14c)

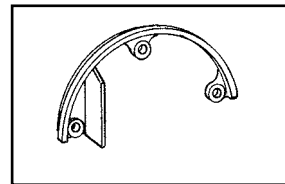

Use GD11122 upper brush retainer when using soybean and cotton discs.

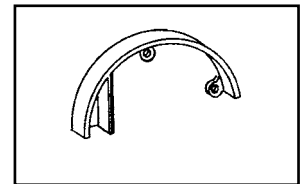

Use GD8237 upper brush retainer when using milo/grain sorghum discs.

SEED METER OPERATION

When installing the seed disc onto the meter hub, turn the disc counterclockwise while tightening the two wing nuts that retain the disc. The seed disc should have only slight resistance when rotated counterclockwise after wing nuts are tight.

The brush-type seed meter attaches to the seed hopper in the same manner as the finger pickup seed meter. Secure to bottom of seed hopper with two $\frac{5}{16}$ " thumbscrews. Tighten thumbscrews slightly with pliers. **DO NOT OVER TIGHTEN.**

Erratic seed spacing may result from misalignment between the drive coupler and seed meter input shaft. Misalignment may cause momentary stoppage of seed disc. Check alignment after initial installation. If adjustment is required, refer to "Meter Drive Adjustment" for correct procedure.

Refer to the planting rate charts in this manual for recommended seed drive transmission sprocket combinations.

One tablespoon of **powdered graphite** should be mixed with the seed each time the hoppers are filled. Regular graphite use will prolong the life of the brush-type seed meter components, improve seed spacing, and may reduce buildup of seed treatments. Apply graphite around the outer perimeter of the hopper as shown below.

D05300104b



NOTE: Do NOT apply graphite only in the center of the hopper. It will filter too quickly through the seed and not distribute as evenly as desired.

NOTE: Additional graphite or talc may be required to retard buildup of seed treatments on meter components. Frequency of monitor seed tube cleaning may be affected due to use of additional graphite or talc.

Talc seed lubricant may be used in lieu of or in addition to graphite to reduce seed treatment buildup on seed disc and meter components. Coat seed disc and brushes with talc before installing meter. Fill hopper $\frac{1}{2}$ full of seed, add $\frac{1}{4}$ cup of talc and **mix thoroughly**. Finish filling hopper, add another $\frac{1}{4}$ cup of talc and **mix thoroughly**. Adjust rate of talc use as needed so all seeds are coated, while avoiding a buildup of talc in the bottom of the hopper. Humid conditions and/or small sized seeds with extra seed treatment may require as much as one cup of talc per hopper to prevent seed treatment buildup on seed disc and/or brushes.

NOTE: Some liquid seed treatments or inoculants may create buildup on the seed disc or brushes. Check frequently for proper population and/or seed delivery when using any liquid seed treatment. All seed treatment should be thoroughly mixed with the seed per the manufacturers' recommendations. Seed treatment dumped on top of the seed after the hopper is filled, and not mixed properly may cause bridging of the seed in the meter, reducing population or stopping the meter from planting.

NOTE: Foreign material, such as hulls, stems, etc., may affect seed delivery. Clean seed is required to ensure accurate seed metering from the brush-type seed meter. Seed discs should be removed daily to check for buildup of foreign material, such as hulls, in the seed meter or the brushes.

CLEANOUT

To maintain genetic purity, thorough seed meter cleanout is important.

To clean the seed meter, disengage the seed drive and remove the seed hopper and meter. Dump the seed from the right rear corner of the hopper into a container. Disassemble seed disc by removing wing nuts. Empty the meter. Thoroughly inspect brushes in meter to ensure all seed is removed. Replace seed disc and install wing nuts.

SEED METER OPERATION

GENERAL PLANTING RATE INFORMATION (EDGEVAC® SEED METERING)

The size and shape of seed may affect the planting rate.

The following seed discs are available for use with the KINZE® EdgeVac® Seed Metering System:

Corn/Popcorn: 39 cell. Light blue color-coded. For all seed corn grades from 35 to 70 pounds per 80,000 kernel count unit or popcorn seed size range from 2210 to 4200 seeds per pound. Also used for No. 1 sunflower seeds. *When planting popcorn this seed disc requires use of seed baffle. See "Seed Meter" on pages 7-2 and 7-3 for additional information.*

Low-Rate Corn/Popcorn: 24 cell. Light green color-coded. For all seed corn grades from 35 to 70 pounds per 80,000 kernel count unit or popcorn seed size range from 2210 to 4200 seeds per pound. Also used for No. 1 sunflower seeds. *When planting popcorn this seed disc requires use of seed baffle. See "Seed Meter" on pages 7-2 and 7-3 for additional information.*

Soybean: 60 cell. Black color-coded. Seed size range from 2200 to 4000 seeds per pound. *This seed disc requires use of seed baffle. See "Seed Meter" on pages 7-2 and 7-3 for additional information.*

Soybean, High-Rate: 120 cell. Dark blue color-coded. Seed size range from 2200 to 4000 seeds per pound. *This seed disc requires use of seed baffle. See "Seed Meter" on pages 7-2 and 7-3 for additional information.*

Milo/Grain Sorghum: 60 cell. Yellow color-coded. Seed size range from 10,000 to 20,000 seeds per pound. *This seed disc requires use of seed baffle and cleanout brush. See "Seed Meter" on pages 7-2 and 7-3 for additional information.*

Hill-Drop Cotton, Acid-Delinted (3 Seeds Per Cell): 20 cell. Brown color-coded. Cotton seed size range from 3800 to 4400 seeds per pound. *This seed disc requires use of cleanout brush w/ball-type ejector. See "Seed Meter" on pages 7-2 and 7-3 for additional information.*

Small Hill-Drop Cotton, Acid-Delinted (3 Seeds Per Cell): 20 cell. Grey color-coded. Cotton seed size range from 4200 to 5200 seeds per pound. *This seed disc requires use of cleanout brush w/ball-type ejector. See "Seed Meter" on pages 7-2 and 7-3 for additional information.*

Cotton, Acid-Delinted/Small Dry Edible Bean: 54 cell. Dark green color-coded. Cotton seed size range from 3800 to 4400 seeds per pound or dry edible bean seed size range from 1200 to 2500 seeds per pound. *This seed disc requires use of cleanout brush w/ball-type ejector. See "Seed Meter" on pages 7-2 and 7-3 for additional information.*

Small Cotton/Sunflower: 54 cell. White color-coded. Cotton seed size range from 4200 to 5200 seeds per pound or sunflower seed sizes No. 2, 3 and 4. *This seed disc requires use of cleanout brush w/ball-type ejector. See "Seed Meter" on pages 7-2 and 7-3 for additional information.*

Large Dry Edible Bean: 54 cell. Tan color-coded. Seed size range from 800 to 1200 seeds per pound.

NOTE: Due to a multitude of variables, seed spacing can be adversely affected at speeds above 5.5 MPH.

NOTE: See "Seed Meter Singulator Brush And Vacuum Level Adjustments" on page 7-24.

SEED METER OPERATION

EDGEVAC® SEED METER

(METR71/METR71a)

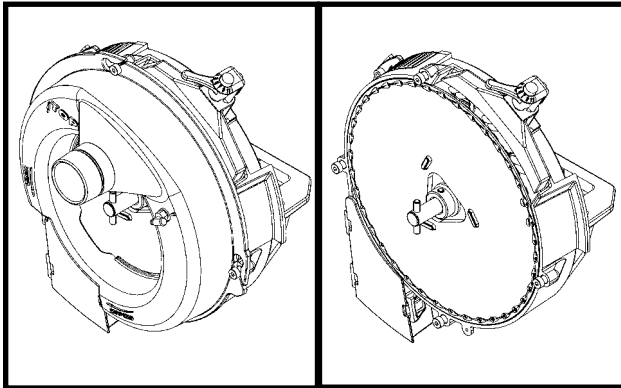

(METR70/D14467a)

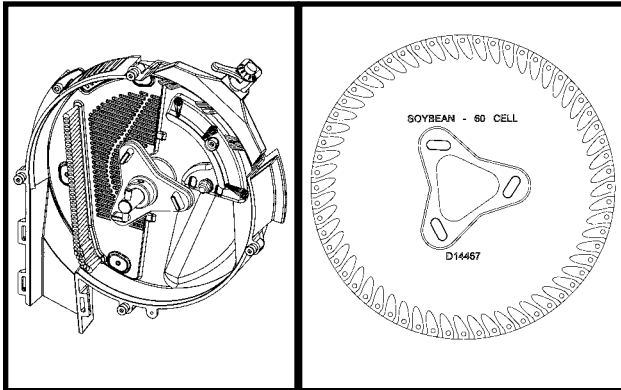

The seed discs below and at right are available for use with the KINZE® EdgeVac® Seed Metering System:

Corn/Popcorn: 39 cell. For all seed corn grades from 35 to 70 pounds per 80,000 kernel count unit. Popcorn seed size range from 2210 to 4200 seeds per pound. Also used for No. 1 sunflower seeds. (*Light blue color-coded.*) (D14465)

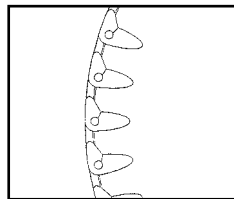

Low-Rate Corn/Popcorn: 24 cell. For all seed corn grades from 35 to 70 pounds per 80,000 kernel count unit. Popcorn seed size range from 2210 to 4200 seeds per pound. Also used for No. 1 sunflower seeds. (*Light green color-coded.*) (D16734a)

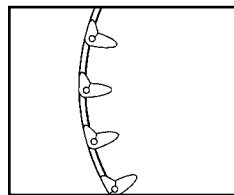

Soybean: 60 cell. Seed size range from 2200 to 4000 seeds per pound. (*Black color-coded.*) (D14467a)

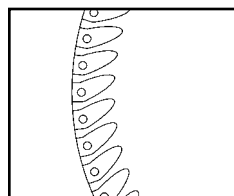

Soybean, High-Rate: 120 cell. Seed size range from 2200 to 4000 seeds per pound. (*Dark blue color-coded.*) (D14468a)

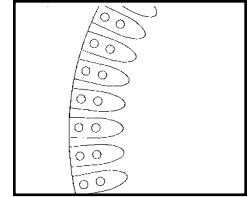

Milo/Grain Sorghum: 60 cell. Seed size range from 10,000 to 20,000 seeds per pound. (*Yellow color-coded.*) (D17050)

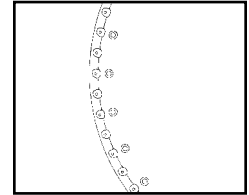

Hill-Drop Cotton, Acid-Delinted (3 Seeds Per Cell): 20 cell. Cotton seed size range from 3800 to 4400 seeds per pound. (*Brown color-coded.*) (D17187)

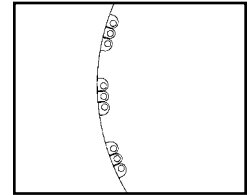

Small Hill-Drop Cotton, Acid-Delinted (3 Seeds Per Cell): 20 cell. Cotton seed size range from 4200 to 5200 seeds per pound. (*Grey color-coded.*) (D17187)

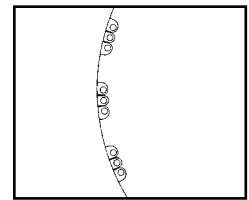

Cotton, Acid-Delinted/Small Dry Edible Bean: 54 cell. Cotton seed size range from 3800 to 4400 seeds per pound. Dry edible bean seed size range from 1200 to 2500 seeds per pound. (*Dark green color-coded.*) (D17186)

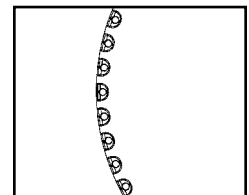

Small Cotton/Sunflower: 54 cell. Cotton seed size range from 4200 to 5200 seeds per pound. Sunflower seed sizes No. 2, 3 and 4. (*White color-coded.*) (D17186)

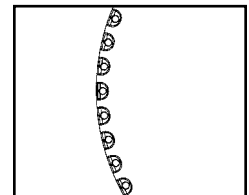

Large Dry Edible Bean: 54 cell. Seed size range from 800 to 1200 seeds per pound. (*Tan color-coded.*) (D14477)

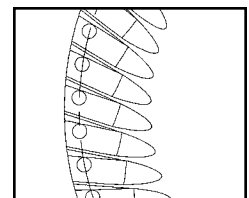

Install the selected seed disc. Position the vacuum cover on the meter by aligning the keyhole slots over the bolt heads. Push the cover on the meter and turn counter clockwise to lock in place. **See following page for additional components required with specific seed discs.**

SEED METER OPERATION

NOTE: Use of damaged seed or seed containing foreign material will cause plugging of seed disc orifices and require more frequent seed meter cleanout to prevent underplanting.

(MTER74)

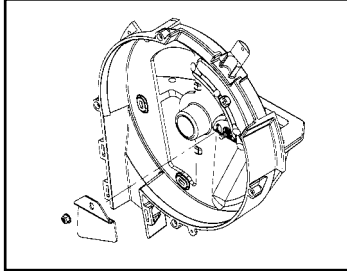

SEED BAFFLE

- Milo/Grain Sorghum
- Soybeans
- Popcorn

The **seed baffle** is designed to prevent excessive seed in the meter from restricting air flow through the seed.

Used with 60 Cell Milo/Grain Sorghum Disc, 60 Cell Soybean Disc, 120 Cell High-Rate Soybean Disc and 39 Cell and 24 Cell Popcorn Discs.

NOTE: Seed baffle is not required with ASD, but is required with conventional hoppers.

(A12133c/A12133aa)

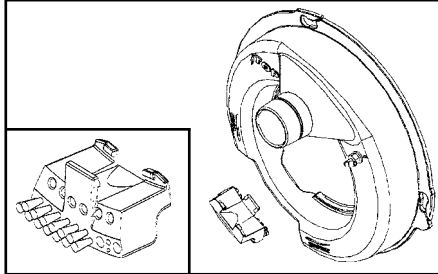

CLEANOUT BRUSH

- Milo/Grain Sorghum

The **cleanout brush** is designed to remove foreign material and seed remnants to help prevent plugging of seed disc orifices.

Used with 60 Cell Milo/Grain Sorghum Disc.

(A12154a/A12133a)

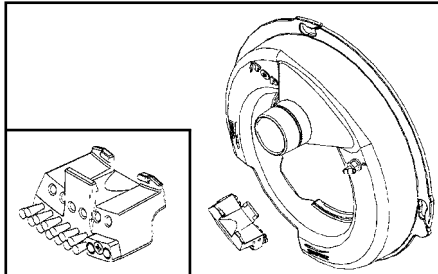

CLEANOUT BRUSH W/BALL-TYPE EJECTOR

- Cotton
- Small Edible Beans

The **cleanout brush w/ball-type ejector** is designed to eject seed remnants from the seed disc orifices.

Used with 20 Cell Hill-Drop Cotton, Acid-Delinted (3 Seeds Per Cell) Discs and 54 Cell Acid-Delinted Cotton/Small Dry Edible Bean; and Small Cotton/Sunflower Discs

NOTE: Foreign material in seed disc orifices, such as seed chips, hulls, stems, etc., may affect seed delivery. Clean seed is required to ensure accurate seed metering from the vacuum seed meter. Seed discs should be removed daily to check for buildup of foreign material in the seed disc orifices.

(METR70)

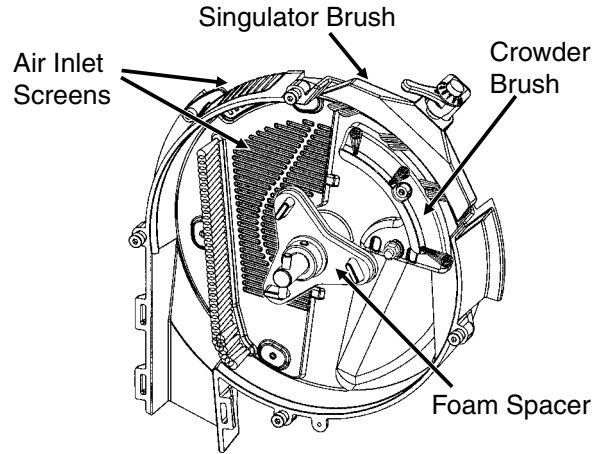

The crowder brush aids in the singulation of small flat seeds by (a) crowding seeds to the outer perimeter of the seed disc and (b) orienting seeds to allow the singulator brush to be more effective.

The air inlet screens allow air to enter the system and aids in keeping field residue or other foreign material out of the meter.

The foam spacer gently preloads the seed disc against the vacuum cover when no vacuum is present.

(METR71)

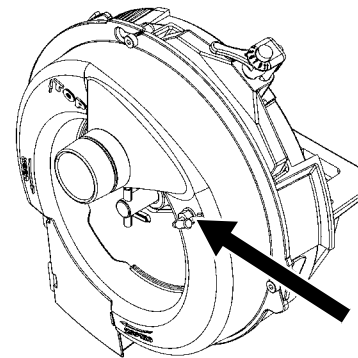

The $\frac{3}{16}$ " hose barb elbow on the seed meter vacuum cover allows measurement of vacuum level at each meter. A customer-supplied vacuum gauge is required.

See "Seed Meter Singulator Brush And Vacuum Level Adjustments", "Seed Meter Maintenance" and "Preparation For Storage" for additional EdgeVac® Seed Metering System information.

SEED METER OPERATION

LUBRICATION - CONVENTIONAL HOPPERS

One tablespoon of **powdered graphite** should be mixed with the seed each time the hoppers are filled. Regular graphite use will prolong the life of the vacuum seed meter components, improve seed spacing, and may reduce buildup of seed treatments. Apply graphite around the outer perimeter of the hopper as shown below.

D05300104b



NOTE: DO NOT apply graphite only in the center of the hopper. It will filter too quickly through the seed and not distribute as evenly as desired.

NOTE: Additional graphite or talc may be required to retard buildup of seed treatments on meter components. More frequent cleaning of monitor seed tubes may be necessary due to use of additional graphite or talc.

Talc seed lubricant may be used in lieu of or in addition to graphite to improve seed release from the meter. Fill hopper $\frac{1}{2}$ full of seed, add $\frac{1}{4}$ cup of talc and **mix thoroughly**. Finish filling hopper, add another $\frac{1}{4}$ cup of talc and **mix thoroughly**. (For sunflowers, increase talc amount from $\frac{1}{4}$ cup to $\frac{1}{2}$ cup.) Adjust rate of talc use as needed so all seeds are coated, while avoiding a buildup of talc in the bottom of the hopper. Humid conditions and/or small sized seeds with extra seed treatment may require as much as one cup of talc per hopper to maintain meter performance.

NOTE: Some liquid seed treatments or inoculants may create buildup on the seed disc or brushes. Check frequently for proper population and/or seed delivery when using any liquid seed treatment. All seed treatment should be thoroughly mixed with the seed per the manufacturers' recommendations. Seed treatment dumped on top of the seed after the hopper is filled, and not mixed properly may cause bridging of the seed in the meter, reducing population or stopping the meter from planting.

Return to Table of Contents

LUBRICATION - ASD HOPPERS

IMPORTANT: Use powdered graphite or talc with each fill of seed. Additional graphite or talc may be required to retard buildup of seed treatments on meter components. Frequency of monitor seed tube cleaning may be affected due to use of additional graphite or talc.

82354-1e



Powdered graphite should be added with the seed each time the bulk seed hopper is filled. Use $1 \frac{1}{2}$ cups per hopper fill for 16 row machines. Graphite should be added in layers as the bulk seed hoppers are filled. The use of powdered graphite will prolong the life of the seed meter components, reduce buildup of seed treatment on components in the meter and improve seed spacing.

Talc seed lubricant may be used in lieu of or in addition to graphite to reduce seed treatment buildup on bulk fill air delivery components, seed discs and other meter components and will improve meter performance. Coat seed discs and brushes with talc before installing meters. Fill each bulk hopper $\frac{1}{2}$ full of seed, add $4 \frac{1}{4}$ cups of talc and mix thoroughly. Finish filling bulk seed hopper, add another $4 \frac{1}{4}$ cups of talc. Adjust rate of talc use as needed so all seeds are coated, while avoiding a buildup of talc in the bottom of the hopper. Humid conditions and/or small sized seeds with extra seed treatment may require additional talc to prevent seed treatment buildup on seed discs and/or other meter components.

SEED METER OPERATION

SEED METER CLEANOUT

To maintain genetic purity, thorough seed meter cleanout is important.

To clean the seed meter, disengage the seed drive and remove the seed hopper and meter. Lay the hopper on its right side.

Disassemble seed meter by rotating vacuum cover clockwise to align key hole slots with bolt heads. Lift off cover. Remove seed disc. Empty the meter and hopper by allowing the seed to run out of the meter. Inspect brushes in meter to ensure all seed is removed. Replace seed disc and install vacuum cover.

NOTE: Use of damaged seed or seed containing foreign material will cause plugging of seed cell orifices and require more frequent seed meter cleanout to prevent underplanting.

SEED METER OPERATION

SEED METER SINGULATOR BRUSH AND VACUUM LEVEL ADJUSTMENTS

SEED DISC SELECTION

CROP	CELLS	SEED SIZE RANGE	COLOR-CODE
Corn	39	35 To 70 Lbs./80,000 Kernel Count Unit	Light Blue
Low-Rate Corn	24	35 To 70 Lbs./80,000 Kernel Count Unit	Light Green
Popcorn	39	2210 To 4200 Seeds/Lb.	Light Blue
Low-Rate Popcorn	24	2210 To 4200 Seeds/Lb.	Light Green
Soybean	60	2200 To 4000 Seeds/Lb.	Black
High-Rate Soybean	120	2200 To 4000 Seeds/Lb.	Dark Blue
Milo/Grain Sorghum	60	10,000 To 20,000 Seeds/Lb.	Yellow
Hill-Drop Cotton, Acid-Delinted (3 Seeds Per Cell)	20	3800 To 5200 Seeds/Lb.	Brown
Cotton, Acid-Delinted	54	3800 To 5200 Seeds/Lb.	Dark Green
Dry Edible Bean (Small)	54	1200 To 2500 Seeds/Lb.	Dark Green
Dry Edible Bean (Large)	54	800 To 1200 Seeds/Lb.	Tan
Small Cotton/Sunflower	54	4200 To 5200 Seeds/Lb.	White

EDGEVAC® INITIAL SETTINGS

CROP	SIZE	SEED DISC	SINGULATOR BRUSH SETTING	VACUUM SETTING (H ₂ O)	SEE NOTES
Corn	35-45 Lbs./80K	Corn/Popcorn	7	20	4, 5
	45-60 Lbs./80K	Corn/Popcorn	6	20	4, 5
	60-70 Lbs./80K	Corn/Popcorn	5	20	4, 5
Popcorn	2210-4200 Seeds/Lb.	Corn/Popcorn	9	18	1, 4, 5
Soybeans	2200-4000 Seeds/Lb.	Soybean	5	10	1
Milo/Grain Sorghum	10,000-20,000 Seeds/Lb.	Milo/Grain Sorghum	7	18	1, 2
Hill-Drop Cotton	3800-5200 Seeds/Lb.	Hill-Drop Cotton	8	23	3
Cotton	3800-5200 Seeds/Lb.	Cotton	8	20	3
Edible Beans	800-1200 Seeds/Lb.	Large Edible Bean	5	18	5
	1200-2500 Seeds/Lb.	Small Edible Bean	6	18	3, 5
Small Cotton/Sunflower	4200-5200 Seeds/Lb.	Small Cotton/Sunflower	5	20	3

NOTES:

1. Requires use of seed meter baffle. Refer to page 7-3 for additional information.
2. Requires use of cleanout brush. Refer to page 7-3 for additional information.
3. Requires use of cleanout brush w/ball-type ejector. Refer to page 7-3 for additional information.
4. For flat seeds, higher vacuum level may be required.
5. Larger seeds may require a lower numbered singulator brush setting from the initial setting. Smaller seeds may require a higher numbered setting.

Refer to the planting rate charts in this manual for seed drive transmission sprocket combinations.

IMPORTANT: See “General Planting Rate Information” and “Checking Seed Population” pages for additional information. Always check seed population in the field to ensure planting rates are correct.

NOTE: Singulator brush settings are marked from 1 thru 11. The lower the singulator brush setting, the less aggressive. The higher singulator brush settings are the most aggressive. Refer to illustrations on page 7-24.

NOTE: Optimum meter performance will be attained with consistent seed size and shape. A mixture of seed sizes and shapes will affect meter performance.

NOTE: Use 1 tablespoon powdered graphite with each hopper fill of seed. Seed treatment, foreign material, dirt or seed chaff may cause gradual reduction of seed disc fill (population). See “Seed Meter”.

NOTE: Excessive seed treatment, humidity and light-weight seed can affect meter performance. Use ½ cup of talc with each hopper fill of seed and mix thoroughly so that all seeds are coated, adjust rates as needed. Use of talc will aid the seed flow into the meter, singulation and seed drop from the disc.

SEED METER OPERATION

STEP 1 Select seed disc (and seed meter baffle, cleanout brush and/or cleanout brush w/ ball-type ejector if applicable) to match crop and population.

STEP 2 Adjust the singulator brush to initial setting. Note that seed size, seed shape, seed treatments, travel speed and planting rate will all affect meter performance.

D06260660

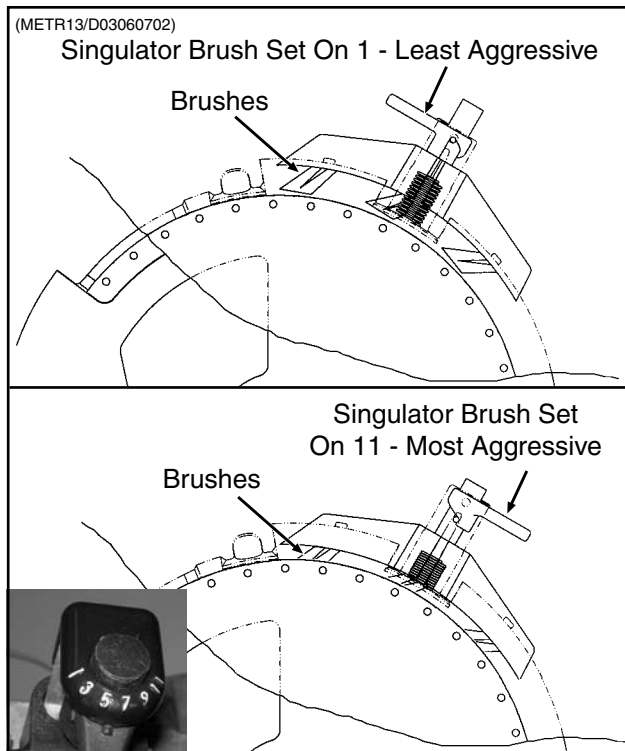
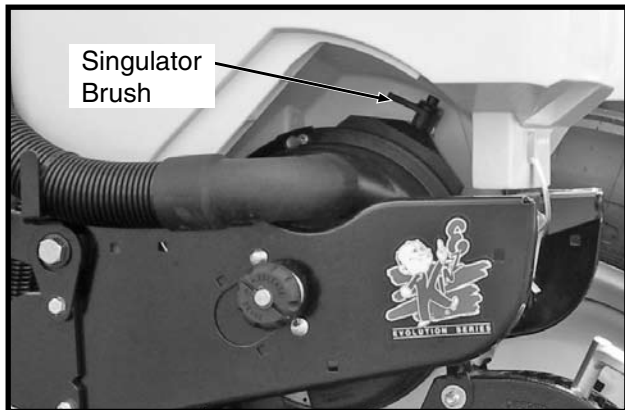

STEP 3 With vacuum fan running, lower planter to planting position and drive forward a short distance to load seed into the seed disc cells.

Adjust vacuum level to the initial setting according to the tables on preceding page. Note that seed size, seed shape, seed treatments, travel speed and planting rate will all affect meter performance.

NOTE: Vacuum reading will be much lower when seed disc cells are empty. Prior to setting vacuum level, load all seed cells.

See “Digital Vacuum Gauge Operation” in Machine Operation section

NOTE: Operate vacuum fan 3-5 minutes to bring oil up to normal operating temperature prior to making the final vacuum level adjustment.

STEP 4 Perform optional seed disc fill check.

D101906132



D101906130



With vacuum hose connected and vacuum fan operating, remove vacuum cover and seed disc as an assembly. Inspect seed discs for proper seed fill.

See “Seed Metering System Troubleshooting” at the end of this section.

SEED METER OPERATION

This page left blank intentionally.

LUBRICATION

The following pages show the locations of all lubrication points. Proper lubrication of all moving parts will help ensure efficient operation of your KINZE® planter and prolong the life of friction producing parts.



WARNING: Always install safety lockup devices or lower the machine to the ground before working under or around the machine.

LUBRICATION SYMBOLS

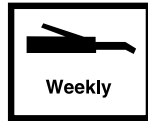
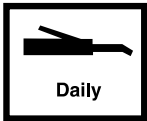

Lubricate at frequency indicated with an SAE multipurpose grease.



Lubricate at frequency indicated with a high quality SAE 10 weight oil or a quality spray lubricant.

SEALED BEARINGS

LF212199-3

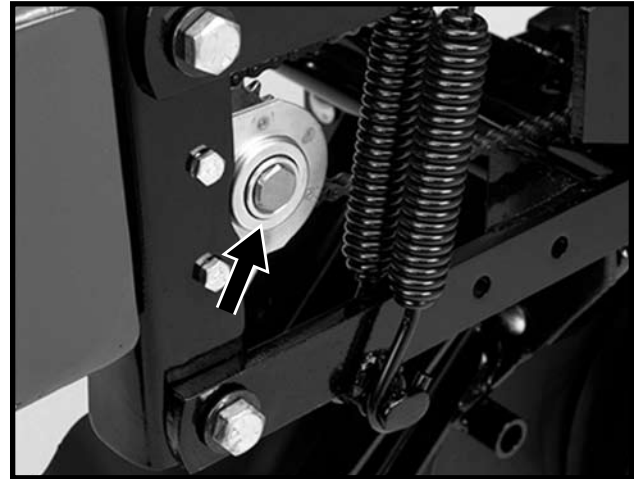

A number of sealed bearings are used on your KINZE® planter to provide trouble free operation. These are located in such areas as the drive shaft, row units and transmission bearings. Sealed bearings are lubricated for life. Due to the seals, relubrication is not practical.

PTO PUMP SHAFT COUPLING (PTO PUMP DRIVE AND OIL COOLER OPTION)

D013109233/TWL290c

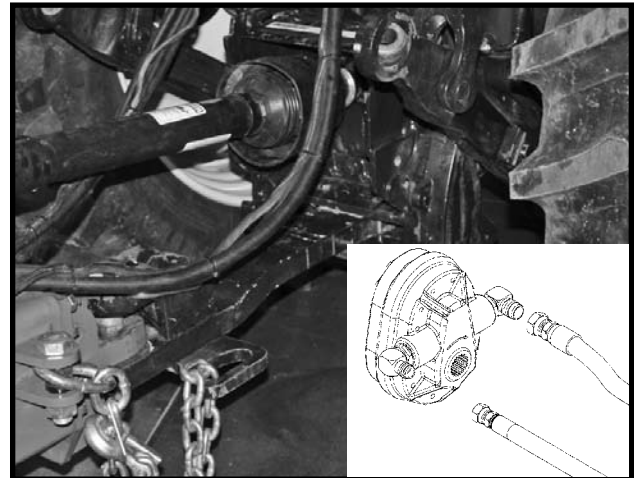

IMPORTANT: The PTO shaft coupling should be cleaned and greased each time the pump is installed.

IMPORTANT: To extend life of shaft splines, apply a coating of high-pressure industrial coupling grease, such as Chevron® Coupling Grease, that meets AGMA CG-1 and CG-2 Standards.

(The Chevron® trademark is owned by Chevron Products Company. AGMA is the acronym for the American Gear Manufacturers Association)

LUBRICATION

AIR CLUTCH CLEANING AND LUBRICATION

(Perform Yearly at End of Planting Season)

NOTE: If system is equipped with Pneumatic Down Pressure air clutches must be removed from planter for cleaning.

NOTE: If system is not equipped with Pneumatic Down Pressure air clutches may be disassembled and cleaned on planter.

At each row unit:

1. Remove meter assembly from row unit.
2. Depress collar on air fitting and remove air hose.
3. Loosen tension from chain and remove from air clutch sprocket.
4. Loosen lock clamp and slide clamp, washer, and air clutch away from chain.

D09160905

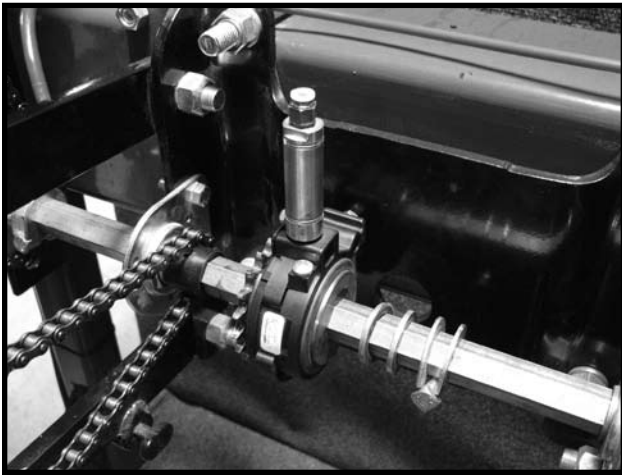

5. Use a $\frac{5}{16}$ " wrench and remove sprocket from air clutch assembly.

D09160902

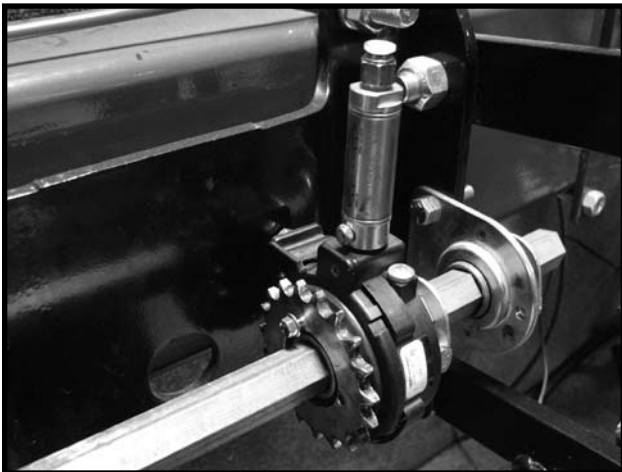

[Return to Table of Contents](#)

6. Remove small Phillips-head screw from side of air clutch housing and remove housing cover.

D09160906

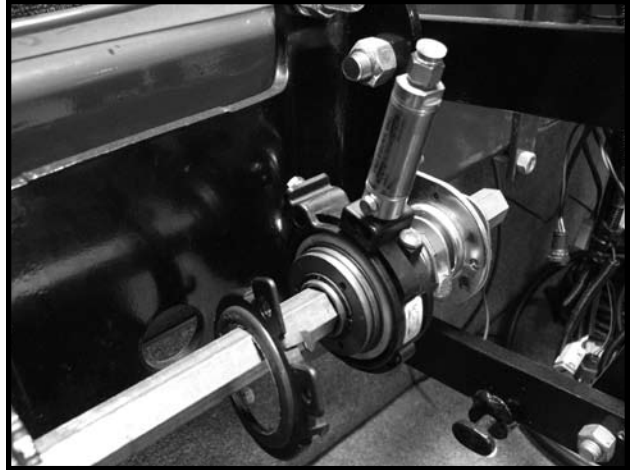

7. Expand retaining ring and remove from assembly.

D09160903



8. Remove and separate sprocket hub, ratchet gear, clutch spring, and hex bushing from air clutch housing.

D09160901



LUBRICATION

9. Remove all loose debris and dirt from clutch components. Clean parts with brake cleaner or equivalent cleaner.
10. Make sure all parts are completely dry and thoroughly lubricate sprocket hub, ratchet gear, clutch spring, and hex bushing with silicone spray.
11. Reverse procedure to assemble air clutch assembly.
12. Place one drop of pneumatic or light-duty hydraulic oil in air cylinder fitting before attaching air line.

D09160904

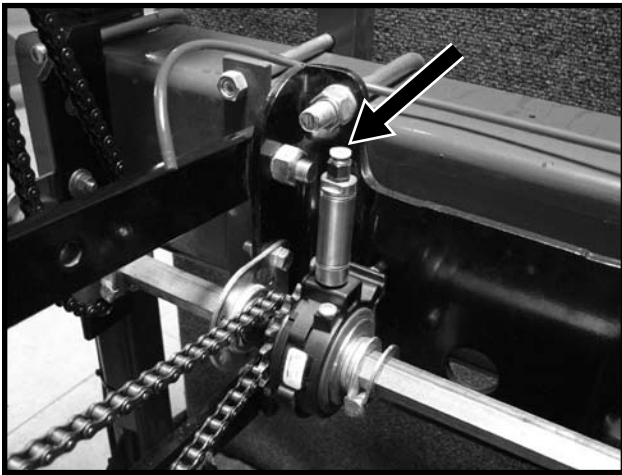

13. Install meter assembly.

AIR CLUTCHES

Lubricate air clutches every 75-100 hours.

Using a Phillips head screw driver remove the Phillips screw as shown and spray a 1-2 second burst of silicone spray into each clutch, then insert and retighten the screws.

D06060802

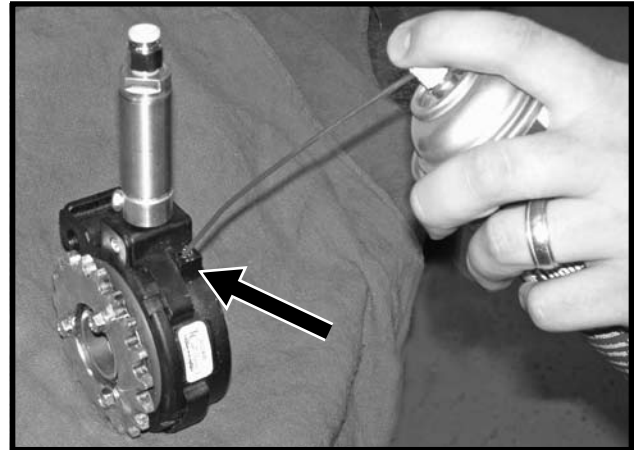

AIR CLUTCH TROUBLESHOOTING

PROBLEM	POSSIBLE CAUSE	SOLUTION
Clutches slip (effected row does not plant or skips).	Plunger in cylinder seized.	Remove airline and lubricated with pneumatic or light duty hydraulic oil.
	Worn Clutch.	Replace worn items.
	Dirt / debris buildup inside clutch.	Disassemble clean as needed. Reassemble.

LUBRICATION

DRIVE CHAINS

All transmission and drive chains should be lubricated daily with a high quality chain lubricant. Extreme operating conditions such as dirt, temperature or speed may require more frequent lubrication. If a chain becomes stiff, it should be removed, soaked and washed in solvent to loosen and remove dirt from the joints. Then soak the chain in oil so the lubricant can penetrate between the rollers and bushings.

D09280611a

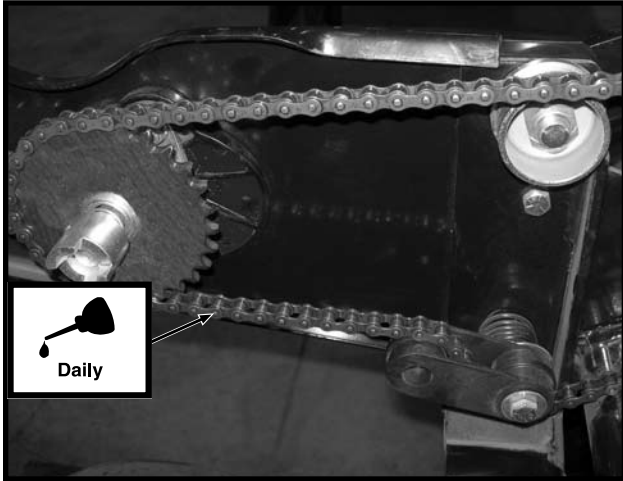

Pull Row Unit Drive Chains

D030209234

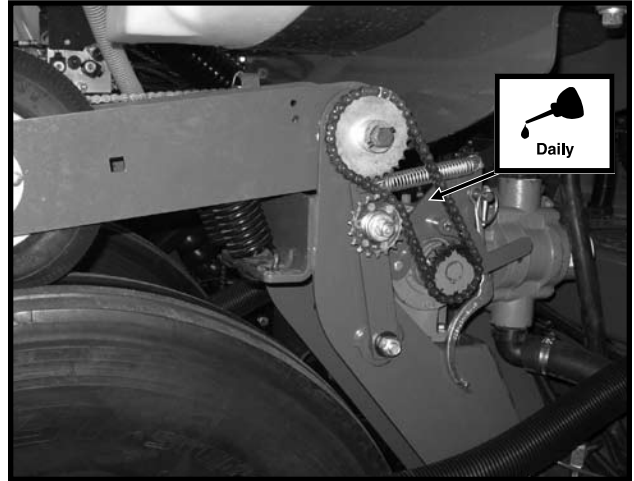

Liquid Fertilizer Ground Drive Chains (Piston Pump)

D051705102

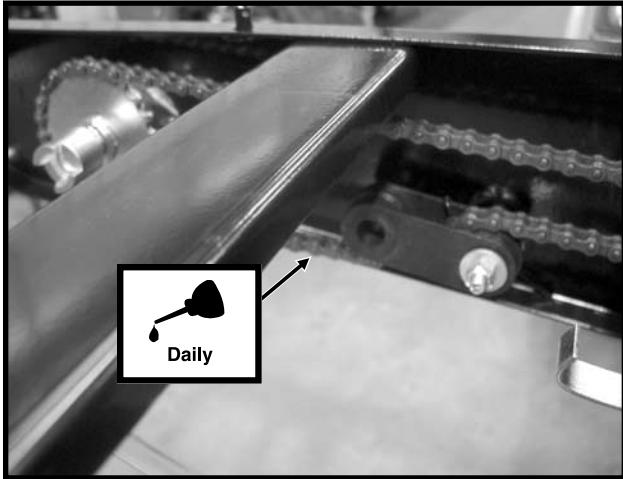

Row Unit Granular Chemical Drive Chains

D030209237

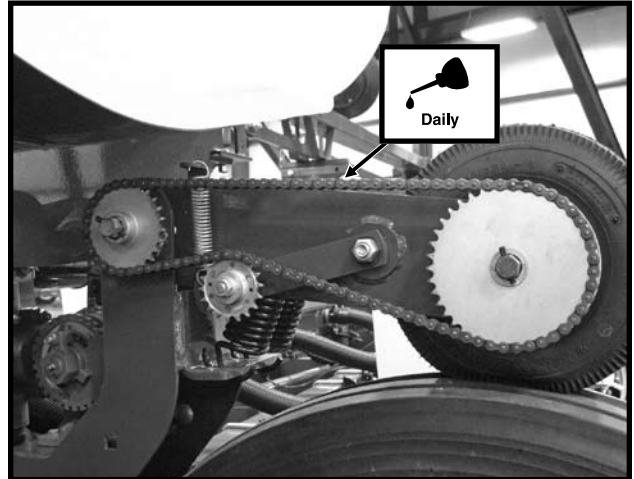

D09280603a

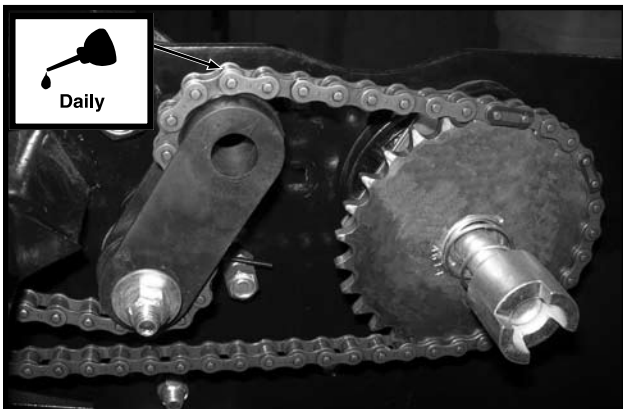

Push Row Unit Drive Chains
[Return to Table of Contents](#)

LUBRICATION

BUSHINGS

Lubricate bushings at the frequency indicated.

Using a torque wrench, check each bolt for proper torque. If bolt is loose, it should be removed and the bushing inspected for cracks and wear. Replace bushing if necessary. **Only hardened flat washers should be used. Replace damaged flat washers with proper part. Torque hardware to 130 ft. lbs.**

D06300305

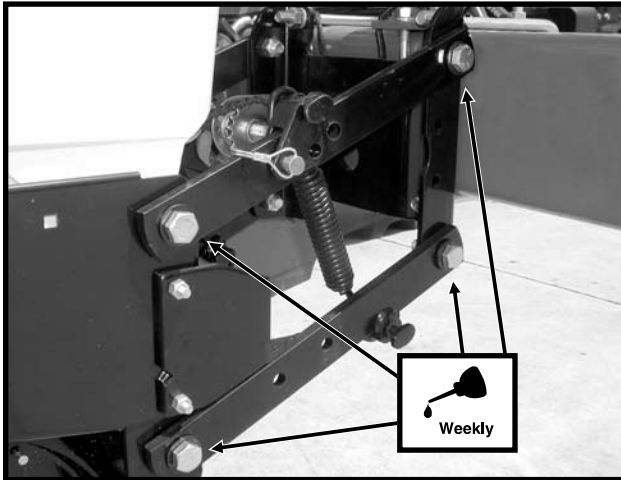

Pull Row Unit And/Or Push Row Unit Parallel Linkages (8 Per Row)

LF212299-22

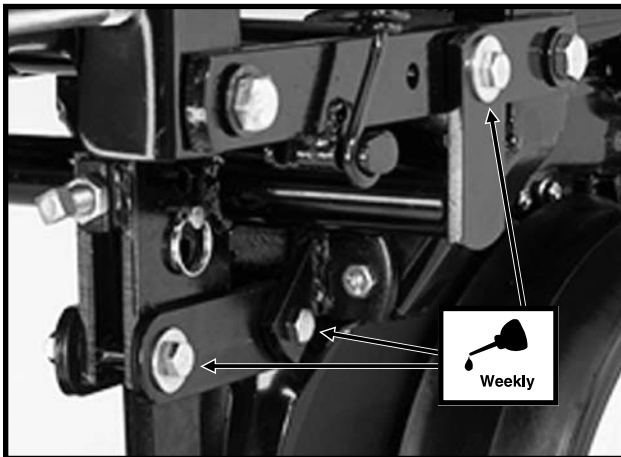

Row Unit Mounted Disc Furrower Parallel Linkages (6 Per Row)

59386-26

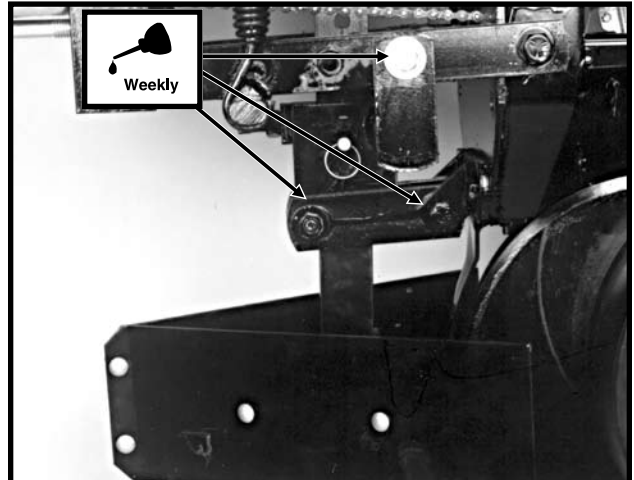

Row Unit Mounted Bed Leveler Parallel Linkages (6 Per Row)

LF212199-2

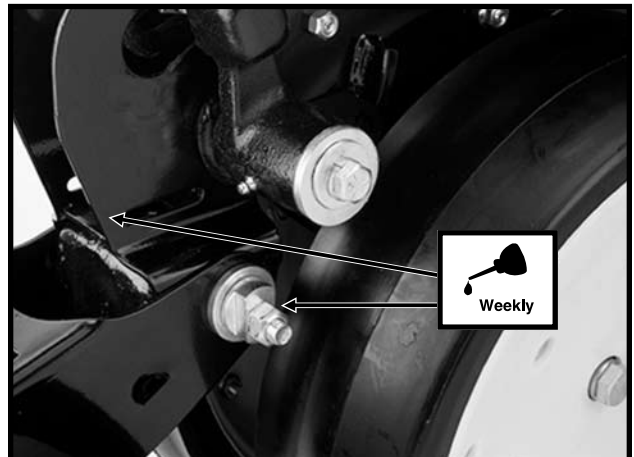

Row Unit "V" Closing Wheel, Covering Discs/ Single Press Wheel And/Or Drag Closing Wheel Eccentric Bushings (2 Per Row)

LUBRICATION

D013009204

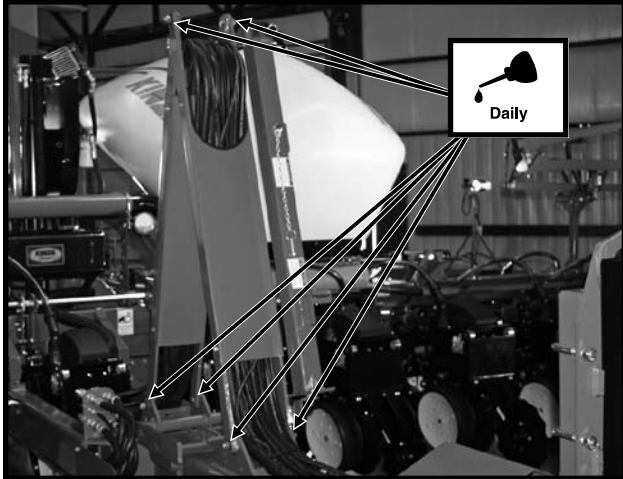

Hose Take-Up (6 Locations)

D013009204

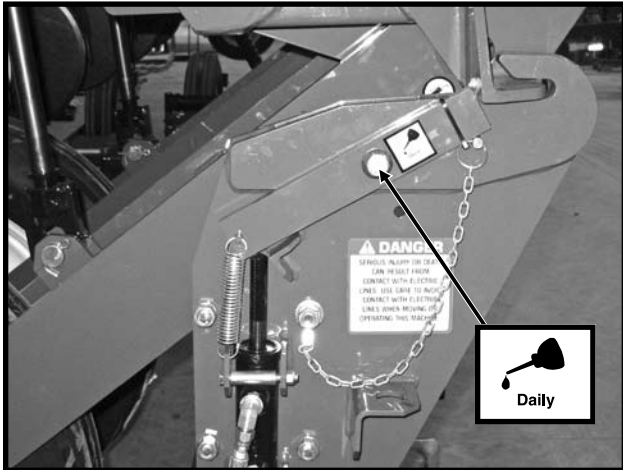

Transport Latch (1 Location)

NOTE: Center post and poly wear pads require no lubrication. Any oil or grease will attract dirt and accelerate wear on the center post and on the poly wear pads.

INTERPLANT® PUSH ROW UNIT LOCKUPS

D06099906

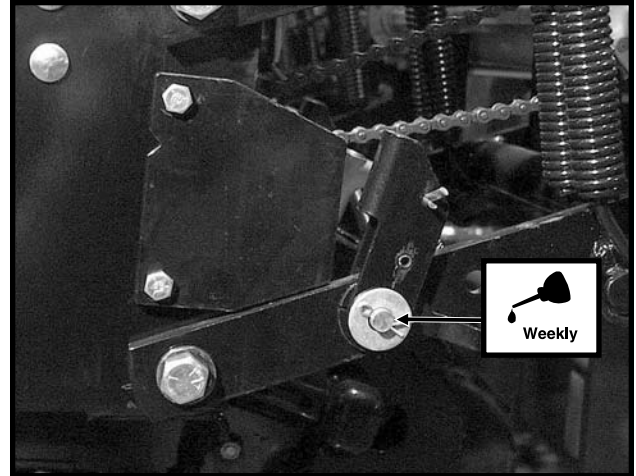

2 Per Row

LUBRICATION

WHEEL BEARINGS

The transport wheel hubs are equipped with grease fittings. Pump grease into the hub until grease comes out around the seals. See "Grease Fittings" for lubrication frequency.

All wheel bearings should be repacked annually and checked for wear. This applies to all drive wheels, transport wheels and marker hubs.

To check for wear, lift the wheel off the ground. Check for endplay in the bearings by moving the tire side to side. Rotate the tire to check for roughness in the bearings. If bearings sound rough, the hub should be removed and the bearings inspected and replaced if necessary. See Maintenance section.

To repack wheel hubs, follow the procedure outlined for wheel bearing replacement with the exception that bearings and bearing cups are reused.

CENTER POST

D013009209

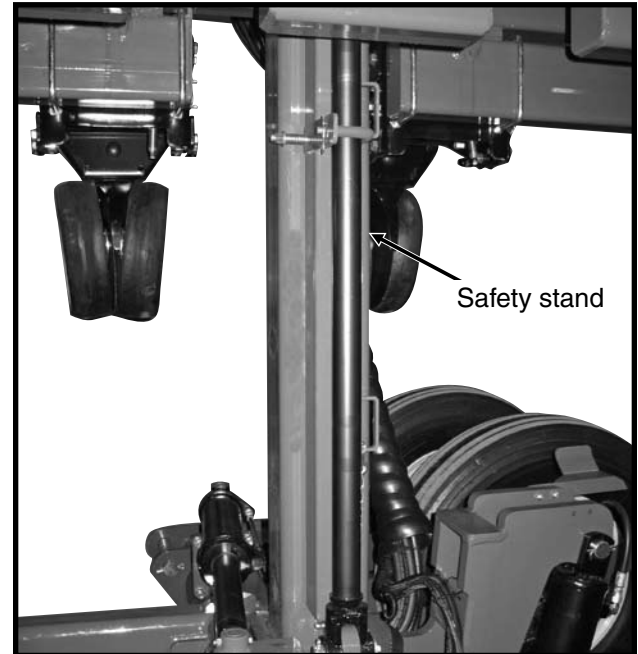

Safety stand in transport position.

NOTE: Center post and poly wear pads require no lubrication. Any oil or grease will attract dirt and accelerate wear on the center post and on the poly wear pads.

U-JOINT SLIDES

Lubricate all U-joint slides daily with a high quality lubricant.

D030509203

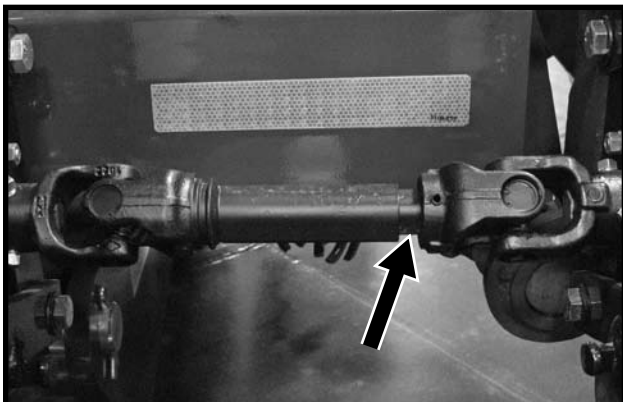

LIQUID FERTILIZER PISTON PUMP CRANKCASE OIL LEVEL

(A12330a)

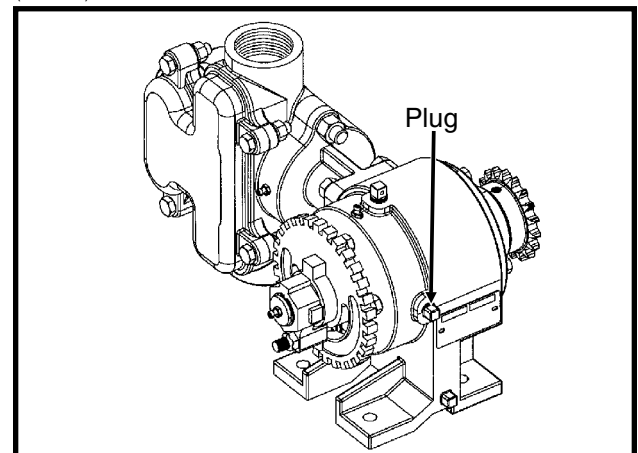

Check crankcase oil daily and maintain at plug level. Fill as needed with EP 90 weight gear oil. Total oil capacity is approximately $\frac{3}{4}$ pint.

Refer to operator and instruction manual supplied with the pump and flow divider for additional information.

LUBRICATION

GREASE FITTINGS

Those parts equipped with grease fittings should be lubricated at the frequency indicated with an SAE multipurpose grease. Be sure to clean the fitting thoroughly before using grease gun. The frequency of lubrication recommended is based on normal operating conditions. Severe or unusual conditions may require more frequent attention.



WARNING: Always install safety lockup devices or lower the machine to the ground before working under or around the machine.

D020609210

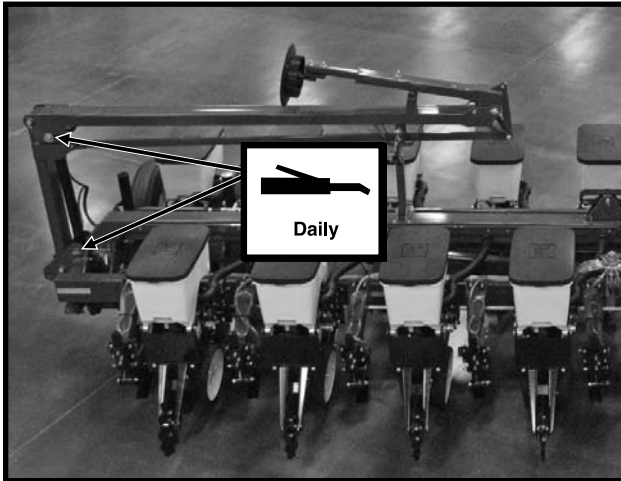

Row Marker Assemblies - Grease Daily
2 fittings per assembly
2 assemblies

D032709207

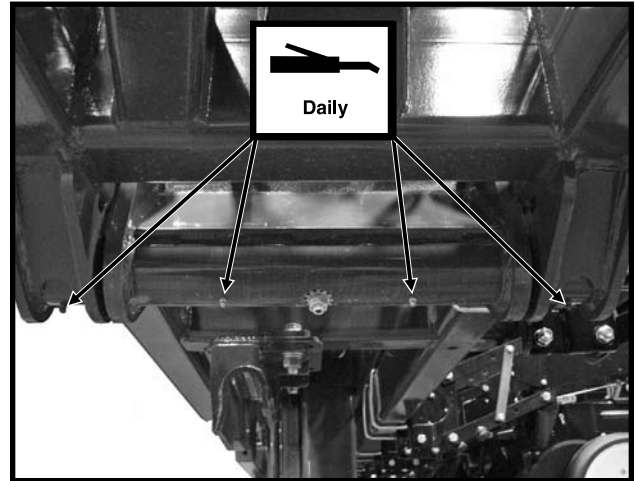

Wing Hinges - Grease Daily
4 fittings per hinge
2 hinges

D032709205

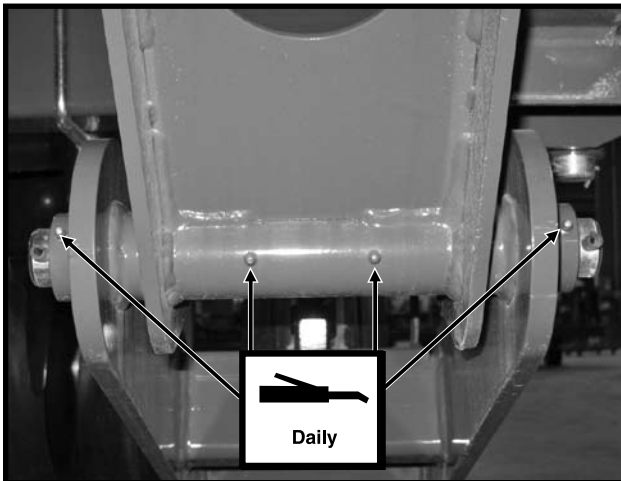

Wing Wheel Pivot - Grease Daily
4 fittings per wing wheel
4 wing wheels

D032709212



Wing Lift Cylinders - Grease Daily
1 per cylinder
4 cylinders

LUBRICATION

D032709209



Rotate Cylinder - Grease Weekly
2 fittings

D032709211

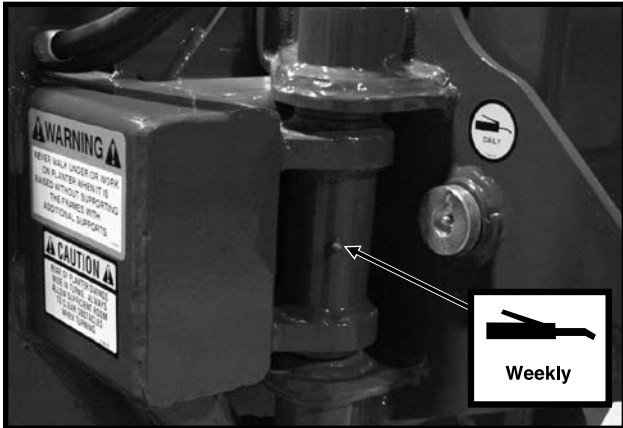

Row Marker Breakaway - Grease Weekly
1 fitting per breakaway
2 breakaways

D032709216

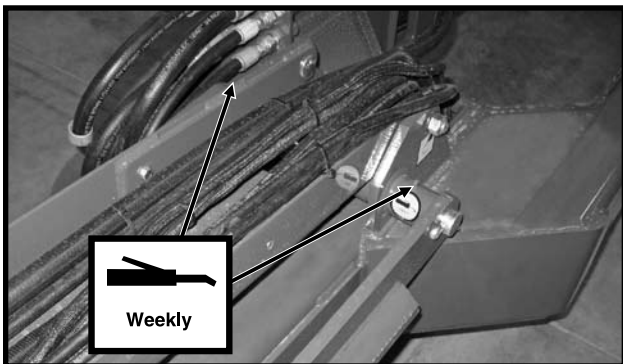

Tongue Hook - Grease Weekly
2 fittings
[Return to Table of Contents](#)

D032709213

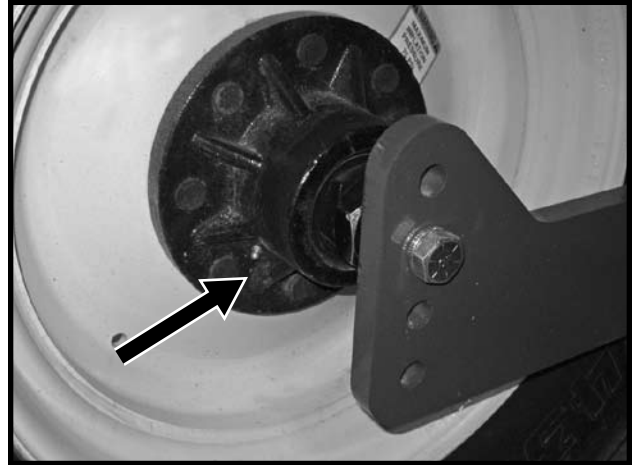

Transport Wheel Bearings - Grease Annually
1 fitting per wheel
4 wheels

D032709214

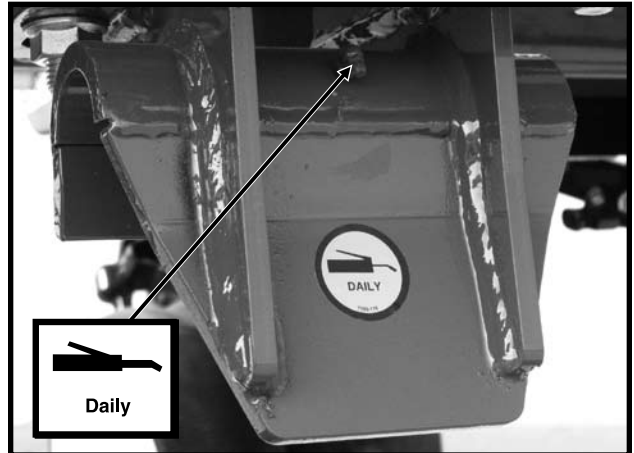

Field Stabilizer - Grease Daily
1 fitting per stabilizer
2 stabilizers

D09110906

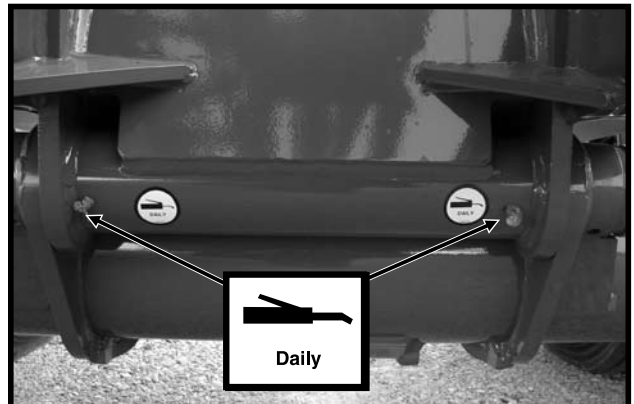

Rock Shaft - 2 fittings

LUBRICATION

D030509203

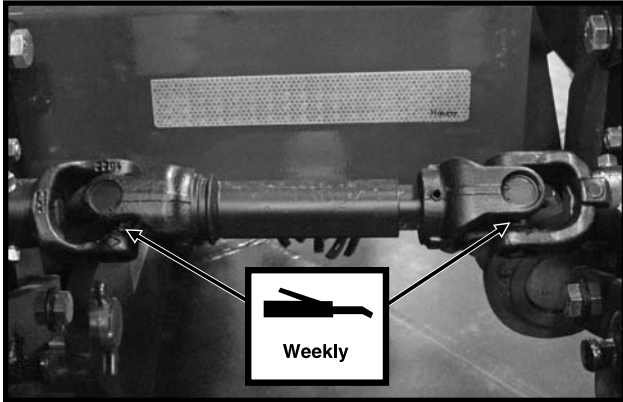

U-Joints - Grease Weekly

- 2 fittings per U-joint
- 2 U-joints w/out Interplant
- 4 U-joints w/Interplant

Row Unit

LF212199-2

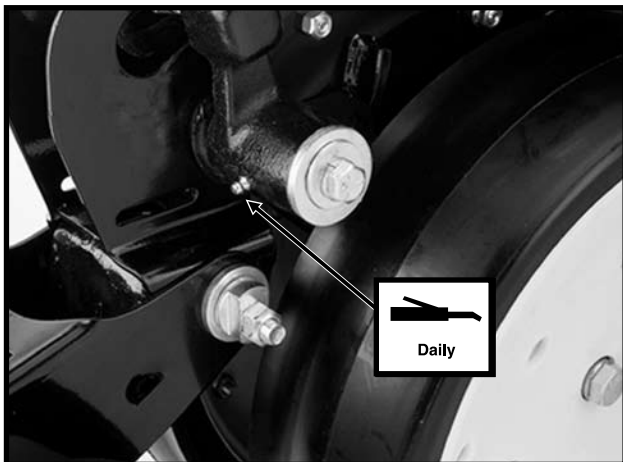

Gauge Wheel Arms - 1 Zerk Per Arm
(Seals in gauge wheel arm are installed with lip facing out to allow grease to purge dirt away from seal. Pump grease into arm until fresh grease appears between washers and arm.)

LF083002101

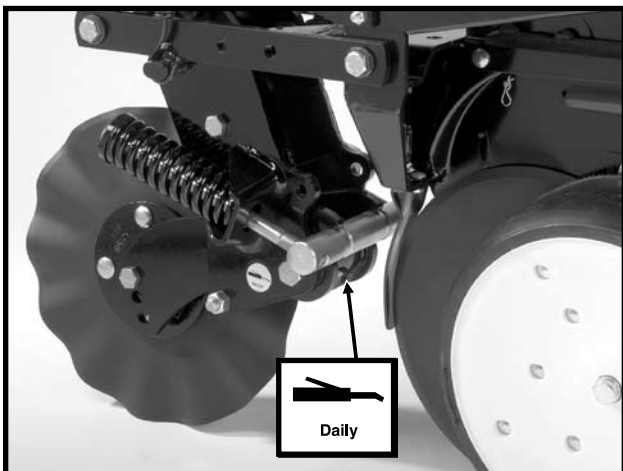

Frame Mounted Coulter - 1 Zerk Per Arm

[Return to Table of Contents](#)

PLANTER MOUNTED PTO PUMP DRIVELINE

IMPORTANT: Lubricate Every 8 Hours

- * Lubricate ball, socket and inner cross kit with at least 15 pumps of grease, or until purged.
- ** Lubricate double yoke and all other areas with at least 10 pumps of grease, or until purged.

7100-351

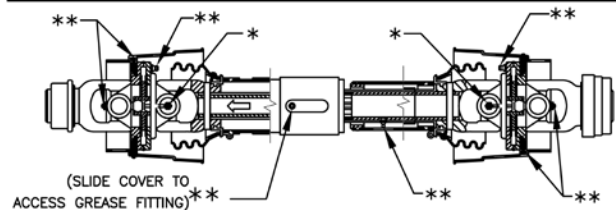

Visually inspect all wear surfaces inside double yoke to ensure presence of grease after lubricating.

D013109240

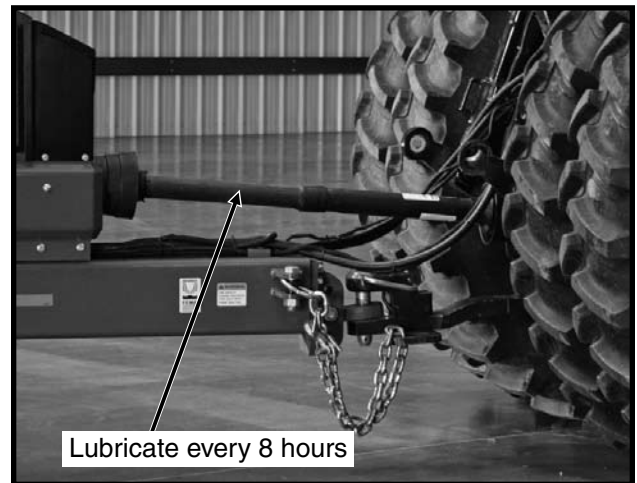

LUBRICATION

Fertilizer Openers

D060801304

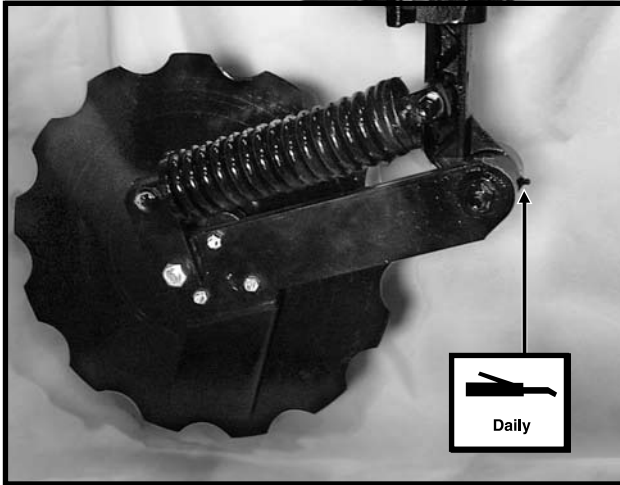

Notched Single Disc Fertilizer Opener - 1 Zerk

D05219901a

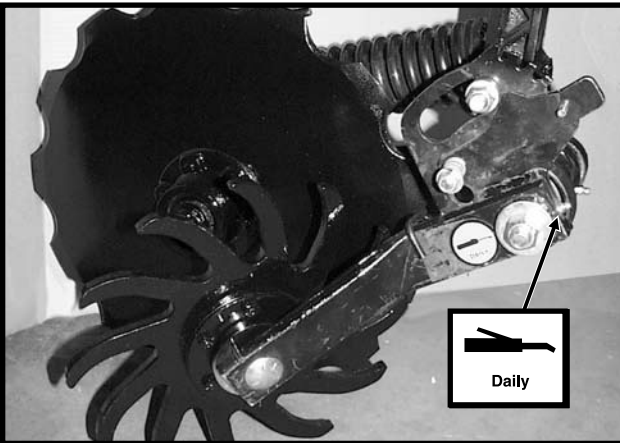

Residue Wheel Attachment For Use With Notched Single Disc Fertilizer Opener - 1 Zerk

D06259919

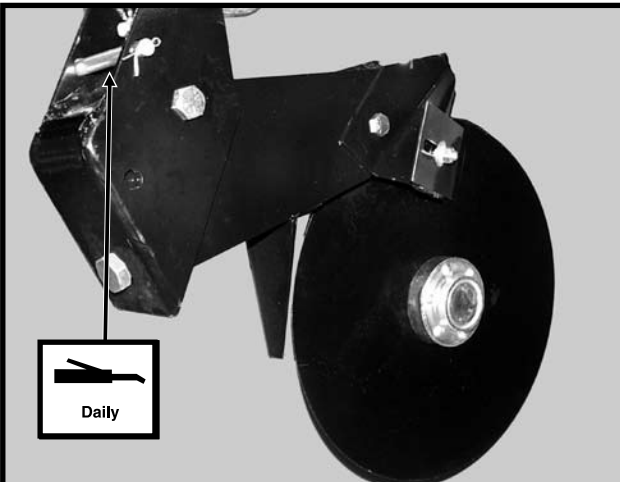

Double Disc Fertilizer Opener - 1 Zerk

D060801304

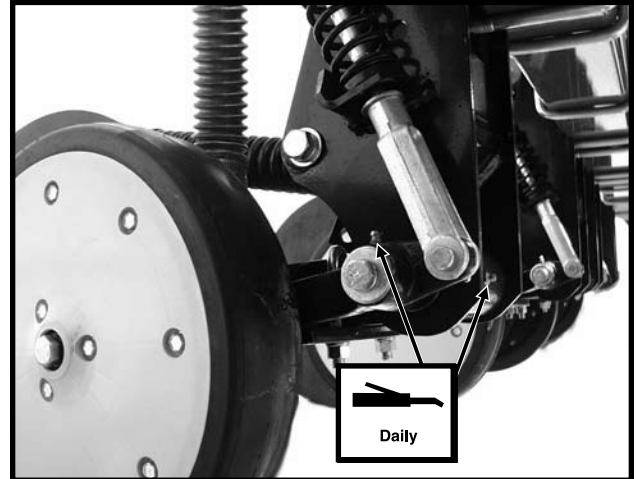

HD Single Disc Fertilizer Opener - 2 Zerks
(Located On Wheel Arm And Opener Mount)

D060801303

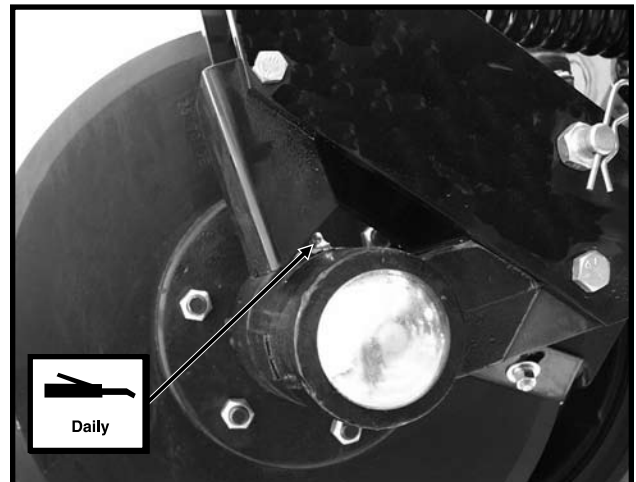

HD Single Disc Fertilizer Opener - 1 Zerk
(Located On Disc Opener Spindle Hub)

Liquid Fertilizer Attachment

A12335a

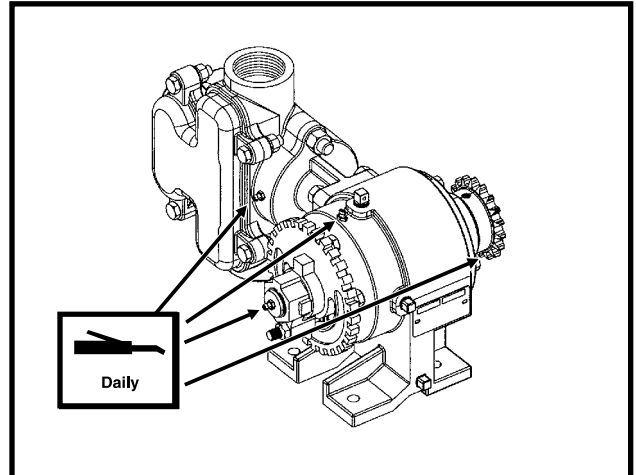

Liquid Fertilizer Piston Pump - 4 Zerks
(Fill zerk on outboard stuffing box until lubricant seeps out of drain hole in bottom.)

LUBRICATION

This page left blank intentionally.

MAINTENANCE

MOUNTING BOLTS AND HARDWARE

Before operating the planter for the first time, check to be sure all hardware is tight. Check all hardware again after approximately the first 50 hours of operation and at the beginning of each planting season thereafter.



WARNING: Before operating the planter for the first time and periodically thereafter, check to be sure the lug nuts on the transport wheels are tight. This is especially important if the planter is to be transported for a long distance.

All hardware used on the KINZE® planter is Grade 5 (high strength), unless otherwise noted. Grade 5 cap screws are marked with three radial lines on the head. If hardware must be replaced, be sure to replace it with hardware of equal size, strength and thread type. Refer to the torque values chart when tightening hardware.

Row Unit Parallel Linkage Bushing Hardware - 130 Ft. Lbs.
 (See “Bushings” in the Lubrication Section of this manual.)
5/8" No Till Coultter Spindle Hardware - 120 Ft. Lbs.
Center Section Transport Tire Lug Nuts - 125 Ft. Lbs.
Wing Ground Drive Tire Lug Bolts - 90 Ft. Lbs.

IMPORTANT: Over tightening hardware can cause as much damage as under tightening. Tightening hardware beyond the recommended range can reduce its shock load capacity.

IMPORTANT: Torque setting for 5/8"-18 hex jam nut that secures fan impellor assembly to motor shaft is 50 ft. lbs.

TORQUE VALUES CHART - PLATED HARDWARE

Bolt Diameter	Grade 2		Grade 5		Grade 8	
	Coarse	Fine	Coarse	Fine	Coarse	Fine
1/4"	50 In. Lbs.	56 In. Lbs.	76 In. Lbs.	87 In. Lbs.	9 Ft. Lbs.	10 Ft. Lbs.
5/16"	8 Ft. Lbs.	9 Ft. Lbs.	13 Ft. Lbs.	14 Ft. Lbs.	18 Ft. Lbs.	20 Ft. Lbs.
3/8"	15 Ft. Lbs.	17 Ft. Lbs.	23 Ft. Lbs.	26 Ft. Lbs.	33 Ft. Lbs.	37 Ft. Lbs.
7/16"	25 Ft. Lbs.	27 Ft. Lbs.	37 Ft. Lbs.	41 Ft. Lbs.	52 Ft. Lbs.	58 Ft. Lbs.
1/2"	35 Ft. Lbs.	40 Ft. Lbs.	57 Ft. Lbs.	64 Ft. Lbs.	80 Ft. Lbs.	90 Ft. Lbs.
9/16"	50 Ft. Lbs.	60 Ft. Lbs.	80 Ft. Lbs.	90 Ft. Lbs.	115 Ft. Lbs.	130 Ft. Lbs.
5/8"	70 Ft. Lbs.	80 Ft. Lbs.	110 Ft. Lbs.	125 Ft. Lbs.	160 Ft. Lbs.	180 Ft. Lbs.
3/4"	130 Ft. Lbs.	145 Ft. Lbs.	200 Ft. Lbs.	220 Ft. Lbs.	280 Ft. Lbs.	315 Ft. Lbs.
7/8"	125 Ft. Lbs.	140 Ft. Lbs.	320 Ft. Lbs.	350 Ft. Lbs.	450 Ft. Lbs.	500 Ft. Lbs.
1"	190 Ft. Lbs.	205 Ft. Lbs.	480 Ft. Lbs.	530 Ft. Lbs.	675 Ft. Lbs.	750 Ft. Lbs.
1 1/8"	265 Ft. Lbs.	300 Ft. Lbs.	600 Ft. Lbs.	670 Ft. Lbs.	960 Ft. Lbs.	1075 Ft. Lbs.
1 1/4"	375 Ft. Lbs.	415 Ft. Lbs.	840 Ft. Lbs.	930 Ft. Lbs.	1360 Ft. Lbs.	1500 Ft. Lbs.
1 3/8"	490 Ft. Lbs.	560 Ft. Lbs.	1100 Ft. Lbs.	1250 Ft. Lbs.	1780 Ft. Lbs.	2030 Ft. Lbs.
1 1/2"	650 Ft. Lbs.	730 Ft. Lbs.	1450 Ft. Lbs.	1650 Ft. Lbs.	2307 Ft. Lbs.	2670 Ft. Lbs.

NOTE: Unplated hardware and bolts with lock nuts should be torqued approximately 1/3 higher than the above values. Bolts lubricated prior to installation should be torqued to 70% of value shown in chart.

	GRADE 2 No Marks		GRADE 5 3 Marks		GRADE 8 6 Marks
--	----------------------------	--	---------------------------	--	---------------------------

TORQUE VALUES- ALUMINUM

Bolt Diameter	Torque Value
1/8"	180-220 In. Lbs.
3/8"	350-380 In. Lbs.
1/2"	350-400 In. Lbs.
3/4"	350-400 In. Lbs.

NOTE: These torque values are to be used with pneumatic down pressure components.

MAINTENANCE

TIRE PRESSURE

D01290926

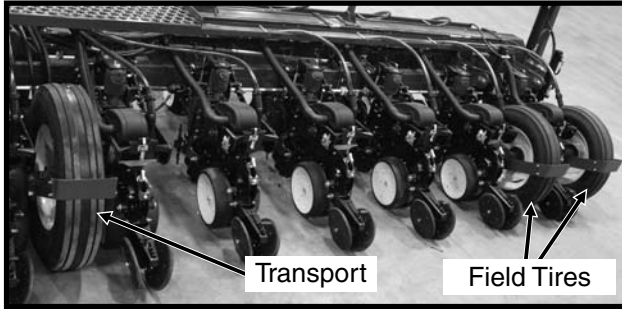

Tire pressure should be checked regularly and maintained as follows:

- 255-70R 22.5" Transport (Center Section) 75 PSI
- 7.50" x 20" Field Tires (Wings) 40 PSI
- 7.60" x 15" Ground Drive
(Liquid Fertilizer Piston Pump) 40 PSI

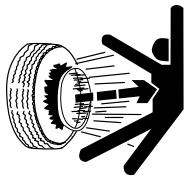

DANGER: Rim and tire servicing can be dangerous. Explosive separation of tire and rim parts can cause serious injury or death.

Do not attempt to mount a tire unless you have the proper equipment and experience to perform the job. This should only be done by persons properly trained and equipped to do the job.

Always maintain the correct tire pressures. Do not inflate the tires above the recommended pressures.

When inflating tires, use a clip-on air chuck and extension hose long enough to allow you to stand to one side and NOT in front of or over the tire assembly. Use a safety cage to enclose the tire and rim assembly when inflating.

Inspect tires and wheels daily. Do not operate with low pressure, cuts, bubbles, damaged rims or missing lug bolts and nuts.

MAINTENANCE

FINGER PICKUP SEED METER INSPECTION / ADJUSTMENT

To inspect or service the finger pickup seed meter, remove the meter from the seed hopper by removing the two thumbscrews which secure the mechanism to the hopper. Remove the baffle from the meter assembly by removing three cap screws. This will permit access to the finger pickup.

D04229901

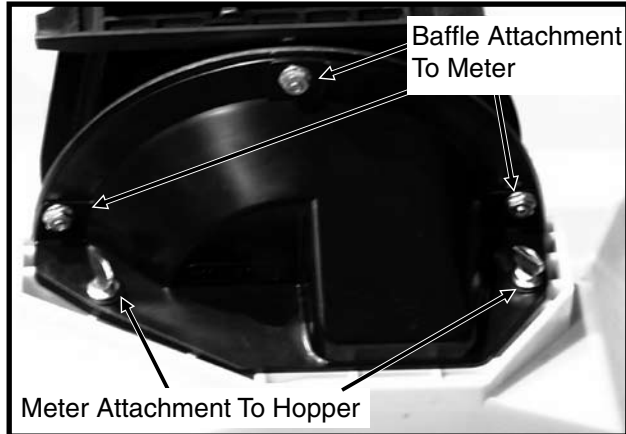

Rotate the seed meter drive by hand to ensure that the springs are holding the tabs of the fingers against the carrier plate where indicated in the photo and that the fingers are being raised in the correct area.

D12220402a

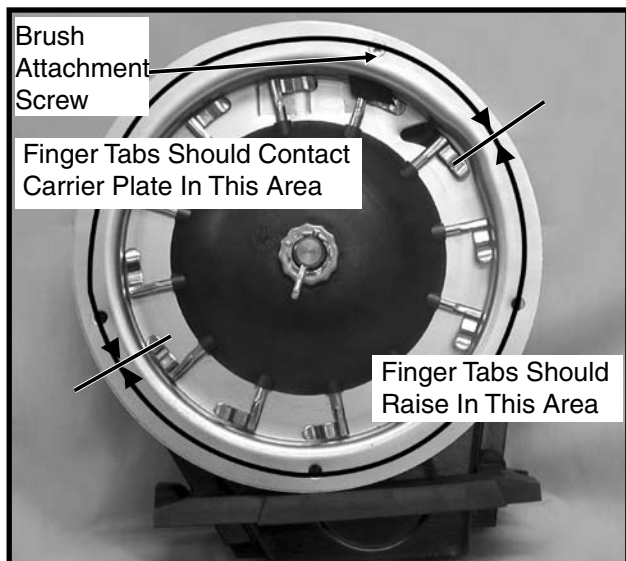

A buildup of debris or chaff may prevent proper finger operation and will require disassembly and cleaning of the finger pickup meter as follows:

1. Remove cotter pin, cover nut and adjusting nut and wave washer (If Applicable) from drive shaft.
2. Carefully lift finger holder, along with fingers and cam, off of the shaft. Clean.

60620-3b

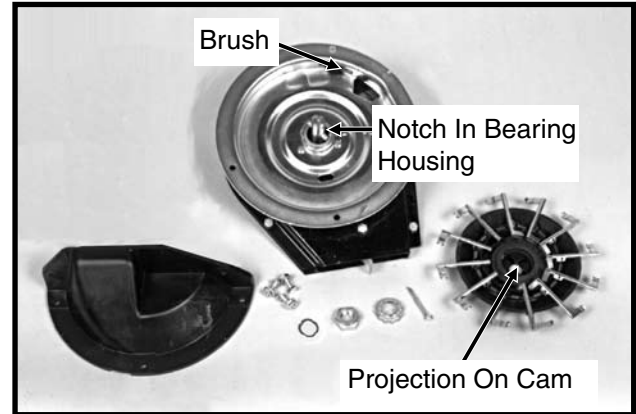

3. Check brush for wear and replace if necessary or following every 100 acres per row of operation.

EXAMPLE: Approximately 800 acres of corn or sunflowers on a 8 row machine, 1200 acres on a 12 row machine or 1600 acres on a 16 row machine.

NOTE: It is not necessary to remove finger holder to replace brush.

4. To replace fingers or springs, remove springs from fingers and remove finger from holder by lifting it out of the friction fit slot. Under average conditions, life expectancy of these parts should be 600-900 acres per row of operation.
5. After cleaning and/or replacing defective parts, reassemble the meter in the reverse order. When replacing fingers, make sure the open end of the spring loop is toward the inside of the finger holder.

60620-22

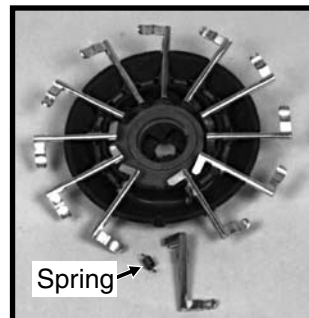

Corn Finger Assembly
(Position Spring Opening Toward Holder)

D07299902



Oil Sunflower Finger Assembly

6. Make sure fingers are installed in holder so that holder will be positioned flush with the carrier plate when assembled. A projection on the cam is designed to align with a mating notch in the bearing housing to ensure proper operation when assembled.

MAINTENANCE

D021506100

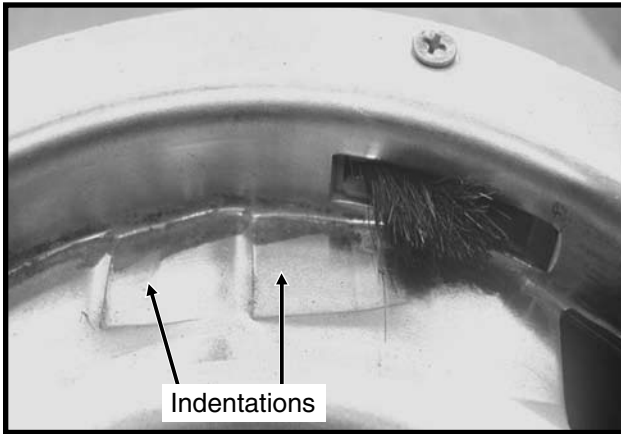

Photo Shows Worn Carrier Plate

- Before installing the finger holder on the carrier plate, check the indentations on the carrier plate for wear. Excessive wear of the carrier plate at the indentations will cause over planting especially when using small sizes of seed.

Inspect the carrier plate annually. Under average conditions, the life expectancy of the carrier plate should be 250-300 acres per row of operation.

- With finger holder flush against the carrier, install wave washer and adjusting nut. Tighten adjusting nut to fully compress wave washer. Then back off nut $\frac{1}{2}$ to 2 flats ($\frac{1}{12}$ to $\frac{1}{3}$ turn) to obtain rolling torque of 22 to 25 inch pounds.

D07299903/D07309912

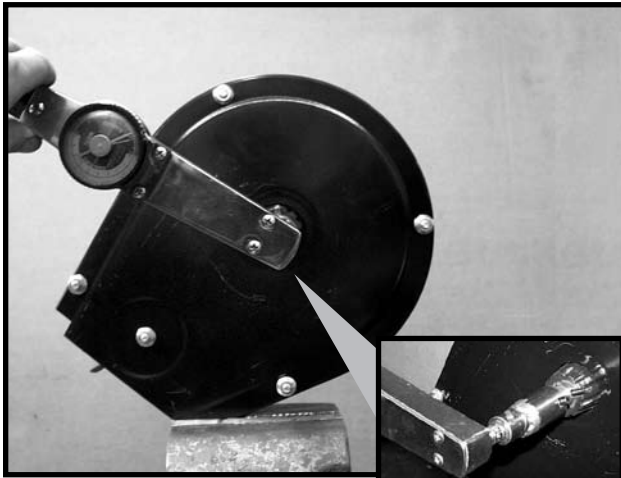

- Turn finger holder by hand to make sure it is positioned firmly against the carrier plate, but is not over tightened and can be rotated with moderate force.
- Install cover nut and cotter pin and reinstall baffle.

NOTE: Check tightness of adjusting nut on each unit after first day of use and periodically thereafter.

To inspect or replace the seed belt, remove the four cap screws around the edge of the housing cover and the nut from the belt idler mounting bolt.

60620-13a/60887-97

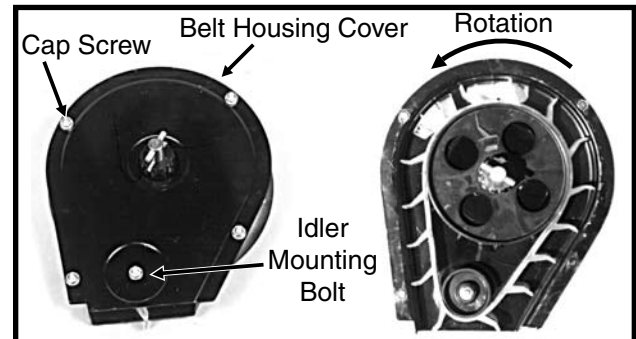

If the belt is being replaced, make sure it is installed to correctly orient the paddles as shown. A diagram molded into the drive sprocket also illustrates the correct orientation.

Reinstall the housing cover. **DO NOT TIGHTEN** hardware at this time. Wedge a screwdriver between the sprocket hub and housing cover as shown below. Pry cover down until it is centered on the belt housing and tighten hardware. Check idler alignment by rotating meter drive shaft. The seed belt should "run" centered on the idler or with only slight contact with the belt housing or cover.

IMPORTANT: Do not over tighten hardware.

D06200030



FINGER PICKUP SEED METER CLEANING

- Disassemble meter.
- Blow out any foreign material present in the meter mechanism.
- Wash in mild soap and water. **DO NOT USE GASOLINE, KEROSENE OR ANY OTHER PETROLEUM BASED PRODUCT.**
- Dry thoroughly.
- Coat lightly with a rust inhibitor.
- Rotate finger assembly so finger does not touch brush.
- Reassemble and store in a dry rodent-free place.

MAINTENANCE

FINGER PICKUP SEED METER TROUBLESHOOTING

PROBLEM	POSSIBLE CAUSE	SOLUTION
One row not planting seed.	Drive release not engaged.	Engage drive release mechanism.
	Foreign material in hopper.	Clean hopper and finger carrier mechanism.
	Seed hopper empty.	Fill seed hopper.
	Row unit drive chain off of sprocket or broken.	Check drive chain.
Unit is skipping.	Foreign material or obstruction in meter.	Clean and inspect.
	Finger holder improperly adjusted.	Adjust to specifications. (22 to 25 in. lbs. rolling torque)
	Broken fingers.	Replace fingers and/or springs as required.
	Planting too slowly.	Increase planting speed to within recommended range.
Planting too many doubles.	Planting too fast.	Stay within recommended speed range.
	Loose finger holder.	Adjust to specifications. (22 to 25 in. lbs. rolling torque)
	Worn brush in carrier plate.	Inspect and replace if necessary.
Overplanting.	Worn carrier plate.	Inspect and replace if necessary.
	Seed hopper additive being used.	Reduce or eliminate additive or increase graphite.
Underplanting.	Seed belt installed backwards.	Remove and install correctly.
	Weak or broken springs.	Replace.
	Spring not properly installed.	Remove finger holder and correct.
	Seed belt catching or dragging.	Replace belt.
	Brush dislodging seed.	Replace brush.
Irregular or incorrect seed spacing.	Driving too fast.	Check chart for correct speed.
	Drive wheels slipping.	Reduce down pressure on row unit down force springs.
Seed spacing not as indicated in charts.	Inconsistent seed size.	Perform field check and adjust sprockets
Scattering of seeds.	Planting too fast.	Reduce planting speed.
	Seed tube improperly installed.	Check seed tube installation.
	Seed tube worn or damaged.	Replace seed tube.
Seed tubes and/or openers plugging.	Allowing planter to roll backward when lowering.	Lower planter only when tractor is moving forward.
Inconsistent seed depth.	Rough seed bed.	Adjust down pressure springs. Reduce planting speed.
	Partially plugged seed tube.	Inspect and clean.
	Seed tube improperly installed.	Install properly.

MAINTENANCE

BRUSH-TYPE SEED METER MAINTENANCE

60607-10a

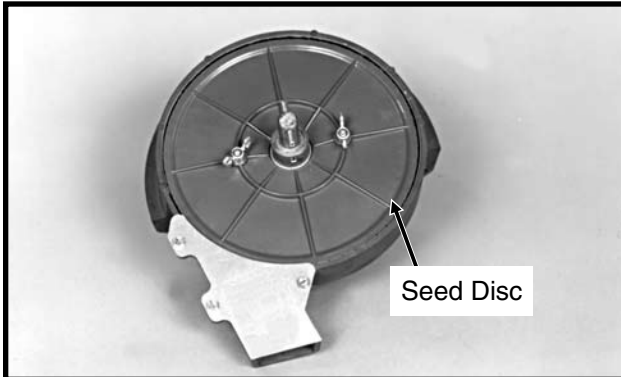

D04239911

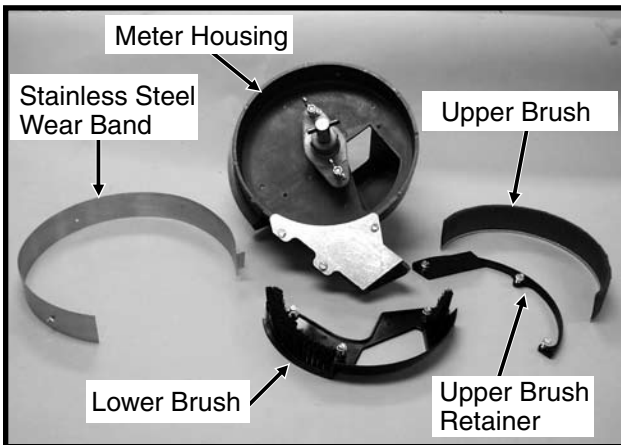

Only clean, high quality seed should be used for maximum meter accuracy. Damaged or cracked seed, hulls or foreign materials may become lodged in the upper brush and greatly reduce meter accuracy. It is suggested that the seed disc be removed daily, inspected and cleaned. Check for buildup of foreign material on the seed disc, particularly in the seed loading slots. Clean the disc by washing it with soap and water. Check for cracked seed, hulls, etc. lodged between the brush retainer and stainless steel wear band which can greatly reduce the accuracy of the meter because the upper brush will not be able to retain the seed in the seed disc pocket. Clean the brush areas of the meter housing thoroughly.

D04239912a



IMPORTANT: Replace hopper lids after hoppers are filled to prevent accumulation of dust or dirt in the seed meter which will cause premature wear.

Cleaning brush-type seed meter for storage:

1. Remove meter from seed hopper by removing the two thumbscrews which secure the meter to the hopper.
2. Remove seed disc and wash with soap and water and dry thoroughly.
3. Remove upper brush by removing the three hex head screws from the brush retainer and removing brush retainer and upper brush.
4. Remove the three hex head screws from the lower brush and remove lower brush and stainless steel wear band.
5. Wash all parts and meter housing with soap and water and dry thoroughly.
6. Inspect all parts for wear and replace worn parts.
7. Reassemble meter except for seed disc. **Meter should be stored in a rodent-free space with seed disc removed.**

Seed Disc Wear

HD112690(PLTR40b)

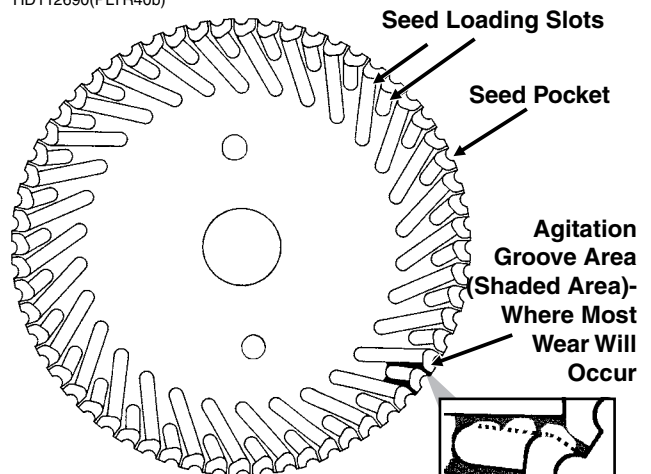

Most wear on the seed disc will be found in the agitation groove area (area between the seed loading slots). Wear will affect planting accuracy at high RPM. To measure for wear, lay a straight edge across the surface of the disc and measure the gap between the disc (at the agitation groove area) and the straight edge. If the agitation groove areas are worn in excess of .030" and accuracy starts to drop off at higher meter RPM, the seed disc should be replaced.

Estimated life expectancy of the seed disc under normal operating conditions should be approximately 200 acres per row. Severe operating conditions such as dust, lack of lubrication or abrasive seed coating could reduce life expectancy of the seed disc to under 100 acres per row.

MAINTENANCE

Upper Brush

D12220403

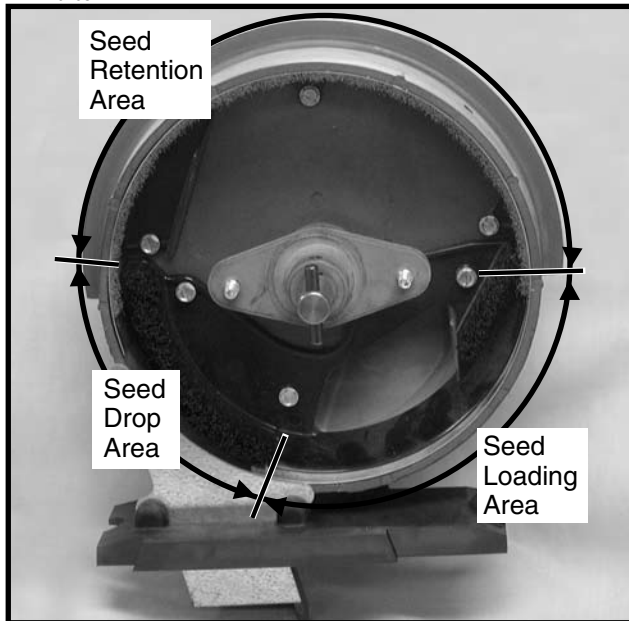

The upper brush holds seed in the seed disc pocket in the seed retention area.

The brush must apply enough pressure against the seed in the seed disc pocket as the disc rotates through the seed retention area to prevent the seed from dropping out of the disc pocket. A damaged spot, excessive wear on the brush or foreign material lodged in the brush may greatly reduce meter performance.

The upper brush should be replaced at approximately 120-400 acres per row of use or sooner if damage or excessive wear is found.

Installation Of Upper Brush

Position upper brush into inner perimeter of seed retention area. Make sure the base of the brush is tight against the bottom of the meter housing. Install brush retainer and three hex head screws. Tighten center screw first, left screw second and right screw last.

NOTE: Use GD11122 upper brush retainer when using soybean and cotton discs. Use GD8237 upper brush retainer when using milo/grain sorghum discs. GD11122 brush retainer shown.

LF212299-13a

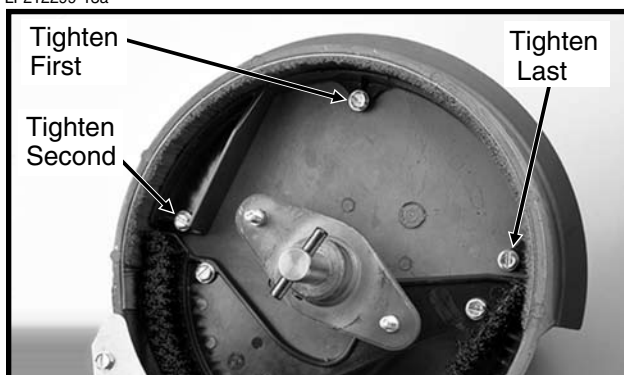

Stainless Steel Wear Band

D04239917a



The purpose of the stainless steel wear band is to protect the meter housing from wear. The band is .030" thick and should be replaced when approximately .020" of wear is found in the primary area of wear. If the wear band is allowed to wear through or if the meter is used without the wear band in place, damage to the meter housing may occur.

Estimated life expectancy of the stainless steel wear band is 240-800 acres per row.

Lower Brush

D04239911

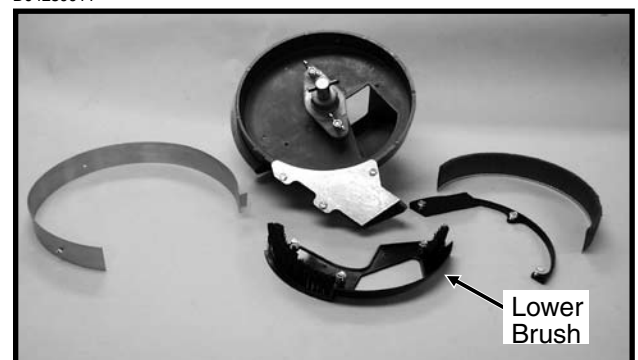

The lower brush has several functions. One function is to move seed down the seed loading slots to the seed pockets. The second function is to isolate seed in the reservoir from entering the seed tube and a third is to clean the seed loading slots.

Estimated life expectancy of the lower brush is 240-800 acres per row. The lower brush should be replaced if the bristles are deformed or missing or if there are cracks in the brush retainer.

MAINTENANCE

BRUSH-TYPE SEED METER TROUBLESHOOTING

PROBLEM	POSSIBLE CAUSE	SOLUTION
Low count.	Meter RPM too high.	Reduce planting speed.
	Seed sensor not picking up all seeds dropped.	Clean seed tube. Switch meter to different row. If problem stays with same row, replace sensor.
	Lack of lubrication causing seeds not to release from disc properly.	Use graphite or talc as recommended.
	Seed size too large for seed disc being used.	Switch to smaller seed or appropriate seed disc. See "Brush-Type Seed Meter" for proper seed disc for size of seed being used.
	Seed treatment buildup in meter.	Reduce amount of treatment used and/or thoroughly mix treatment with seed. Add talc.
Low count at low RPM and higher count at higher RPM.	Foreign material lodged in upper brush.	Remove seed disc and remove foreign material from between brush retainer and bristles. Clean thoroughly.
	Worn upper brush.	Replace. See "Maintenance".
Low count at higher RPM and normal count at low RPM.	Seed disc worn in the agitation groove area.	Replace disc. See "Maintenance".
High count.	Seed size too small for seed disc.	Switch to larger seed or appropriate seed disc.
	Upper brush too wide (fanned out) for small seed size.	Replace upper brush.
High count. (Milo/Grain Sorghum)	Incorrect brush retainer being used.	Make sure GD8237 brush retainer is installed to keep upper brush from fanning out.
Upper brush laid back.	Seed treatment buildup on brush.	Remove brush. Wash with soap and water. Dry thoroughly before reinstalling. See "Maintenance".
	Buildup of foreign material at base of brush.	Remove brush retainer and brush. Clean thoroughly. Reinstall.

MAINTENANCE

EDGEVAC® SEED METER MAINTENANCE

(METR71)

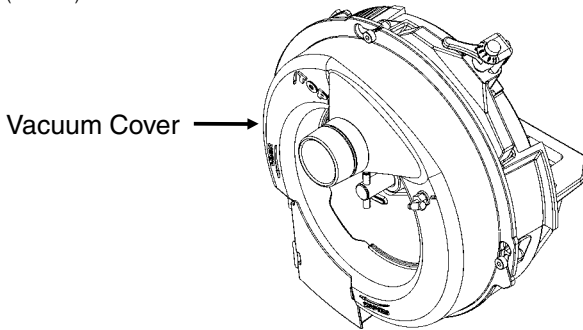

Clean, high quality seed should be used for maximum meter accuracy. Damaged or cracked seed, hulls or foreign material may become lodged in the seed disc orifices and greatly reduce meter accuracy.

It is suggested that the seed disc be inspected and cleaned daily, checking for any buildup of foreign material or any blocked orifices. Clean the seed disc by washing it with soap and water as needed. Dry thoroughly.

Inspect singulator brush for wear and replace if necessary following every 200 acres per row of operation.

The seed disc and/or vacuum cover should be replaced if abnormally high vacuum is required for consistent operation or if consistent operation can not be achieved. If adjustment of the singulator brush does not affect performance of the meter or if the brushes appear frayed, the singulator brush may need to be replaced. If the seed disc orifices are plugged frequently with seed remnants, the cleanout brush or cleanout brush with ball-type ejector (if applicable) may need to be replaced. High quality seed should be used to attain best performance.

(METR70)

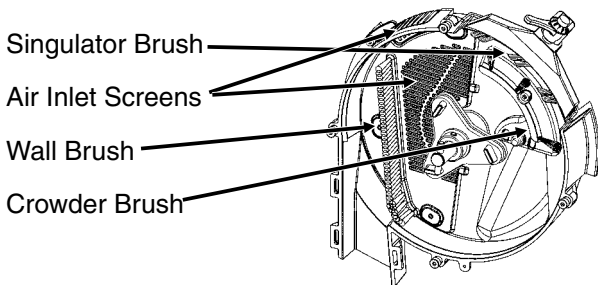

Prior to each planting season, inspect seed discs, singulator brush, crowder brush, wall brush and air inlet screens and clean or replace as needed.

See "Preparation For Storage" for additional EdgeVac® Seed Metering System maintenance.

IMPORTANT: Replace hopper lids after hoppers are filled to prevent accumulation of dust or dirt in the seed meter which will cause premature wear.

NOTE: Remove seed discs from meters for annual storage and store the seed discs vertically on a dowel or pipe.

VACUUM MANIFOLD MAINTENANCE

In the course of normal operation, dust will accumulate in manifolds and hoses. Manifolds should be cleaned annually. More frequent cleaning may be necessitated by abnormally dusty planting conditions.

Remove vacuum hose from each seed meter. Operate the vacuum fan at full hydraulic flow from the tractor for two minutes to clear manifolds, hoses and fittings of dust and debris.

MAINTENANCE

EDGEVAC® SEED METERING SYSTEM TROUBLESHOOTING

PROBLEM	POSSIBLE CAUSE	SOLUTION
Low seed count.	Meter RPM too high.	Reduce planting rate or planting speed.
	Singulator brush setting too aggressive.	Adjust singulator brush.
	Vacuum level too low.	Increase fan speed.
	Seed sensor not picking up all seeds dropped.	Clean seed tube. Move meter to different row.
	Seeds sticking to seed disc.	Use graphite or talc to aid release.
	Seed treatment buildup in seed disc recesses.	Reduce amount of treatment used and or mix thoroughly. Add talc.
	Seed size too large for disc used.	Use appropriate disc for seed size.
	Wrong seed disc.	Use appropriate disc for seed type and size.
	Failed/worn drive components.	Inspect and replace parts as required.
	Plugged orifices in seed disc.	Inspect and clean disc. Check cleanout brush. (If Applicable)
	Loss of vacuum at meter.	Check for foreign material between vacuum cover and disc. Inspect parts for wear/damage. Clean or replace as required.
	Seed bridging in hopper.	Add graphite to improve seed flow.
	Faulty vacuum gauge reading.	Repair/replace gauge.
	Dirt in vacuum manifold.	Check vacuum manifold for dirt and clean.
	Seed baffle (If Applicable) not allowing seed flow due to bridging of seed.	Thoroughly mix talc to coat all seeds. Remove seed baffle. See "Seed Meter" in Seed Meter Operation/Maintenance section.
	Not planting seed.	60 cell soybean disc not filling properly due to excessive RPM.
Seed disc worn.		Replace.
Vacuum cover worn.		Replace.
Seed hoppers empty.		Fill seed hopper.
Seed tube plugged/damaged.		Clean or replace tube.
Meter drive damaged.		Repair/replace drive components.
Low/no vacuum.		Inspect vacuum system and repair as necessary.
Singulator brush setting too aggressive.		Adjust singulator brush.
Faulty vacuum gauge.		Repair/replace vacuum gauge.
Seed bridging in hopper.		Add graphite to improve seed flow.
Loss of vacuum at meter.		Check for foreign material between vacuum cover and disc. Inspect parts for wear/damage. Clean and/or replace as required.
Wrong seed disc.		Use appropriate disc for seed type and size.
Meter drive clutch not engaged.	Engage drive clutch.	
Fan not running.	Start fan.	
Dirt in vacuum manifold.	Check vacuum manifold for dirt and clean.	

MAINTENANCE

EDGEVAC® SEED METERING SYSTEM TROUBLESHOOTING

PROBLEM	POSSIBLE CAUSE	SOLUTION
Not planting seed. (Continued)	Seed baffle (If Applicable) not allowing seed flow due to bridging of seed.	Thoroughly mix talc to coat all seeds. Remove seed baffle. See "Seed Meter" in Seed Meter Operation/Maintenance section.
	60 cell soybean disc not filling properly due to excessive RPM.	Replace with 120 cell soybean disc.
High seed count.	High vacuum.	Adjust vacuum level to appropriate level.
	Wrong seed disc.	Replace seed disc.
	Singulator brush setting not aggressive enough.	Adjust singulator brush.
	Worn singulator brush.	Inspect brush and replace as required.
	Seed leaking past wall brush.	Inspect wall brush condition and installation. Replace as necessary.
	Faulty vacuum gauge.	Check gauge line for dirt/obstruction. Repair/replace vacuum gauge.
Poor seed spacing.	Obstruction in seed tube.	Clean seed tube.
	Dirty/damaged seed disc.	Inspect seed disc for damage, foreign material in orifices or seed treatment buildup in recesses. Clean or replace as required.
	Wrong vacuum setting.	Adjust vacuum to appropriate level.
	Excess foreign material in seed.	Inspect and clean meter and seed discs. Use clean, undamaged seed.
	Incorrect singulator brush setting.	Adjust singulator brush to appropriate setting.
	Inconsistent driveline.	Inspect drive components for rust, misalignment, worn or damaged parts. Replace/repair as required.
	Toolbar not level or wrong height.	Adjust hitch to level toolbar and row units.
	Planting too fast for conditions.	Reduce speed.
	Rough field conditions.	Reduce speed.
Irregular seed population.	Driving too fast.	Reduce speed.
	Drive wheels slipping.	Reduce speed. Decrease row unit down pressure spring settings.
Unable to achieve desired vacuum level.	Tractor hydraulic flow set too low.	Increase flow to fan motor.
	Incorrect hydraulic connections.	Check all hydraulic connections and hose routings
	Damaged fan components.	Inspect motor and impeller for wear/damage and repair/replace as necessary.
	Vacuum hose pinched/kinked/blocked.	Inspect air lines for any damage or obstruction. Clean air lines and manifold by fan at high speed.
	Vacuum hose loose/disconnected.	Inspect and reattach all air hoses.
	Tractor not producing required hydraulic flow/pressure.	Have tractor serviced by qualified technician.
	Dirt in vacuum gauge line.	Check gauge line for dirt/obstruction and clean

MAINTENANCE

PLANTER MOUNTED PUMP DRIVE AND OIL COOLER OPTION

Drain reservoir and change filter annually.

To drain the reservoir, remove the left side panel from pump housing and pull drain hose out to clear planter. Remove cap from end of drain hose and drain oil into container. Replace 10-micron spin-on filter.

Replace and tighten cap, return drain hose to storage location, and refill system with SAE 10W-20 multigrade wide temperature range transmission hydraulic fluid. Reservoir capacity is approximately 10 gallons.

Start system and run with tractor at idle and the fan turned off for 1–2 minutes. Then, run tractor at idle and the fan at full speed for another 1–2 minutes. Check reservoir fluid level and fill as required. After the system is fully primed, fill reservoir to only within 1"–2" of top to allow for heat expansion.

Bring tractor to full PTO speed and adjust flow control for desired system pressure.

NOTE: Periodically check and clean oil cooler.

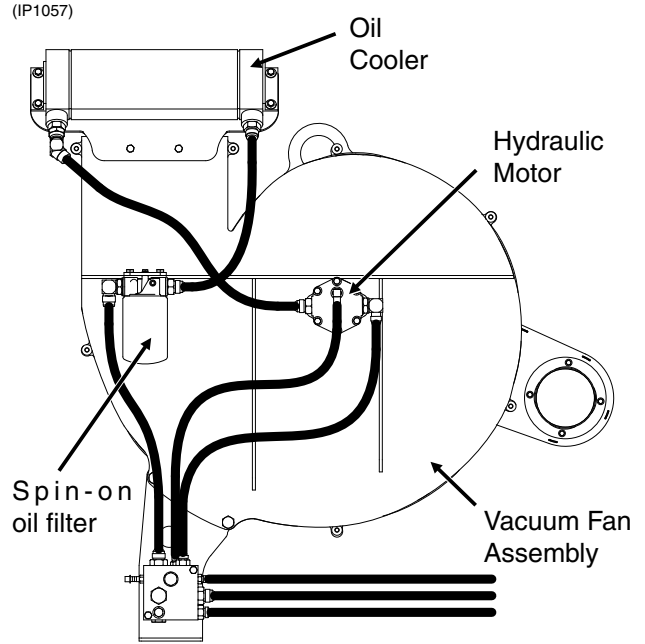

Flow control valve - ASD fan (opposite side)
Flow control valve - EdgeVac® fan (shown)

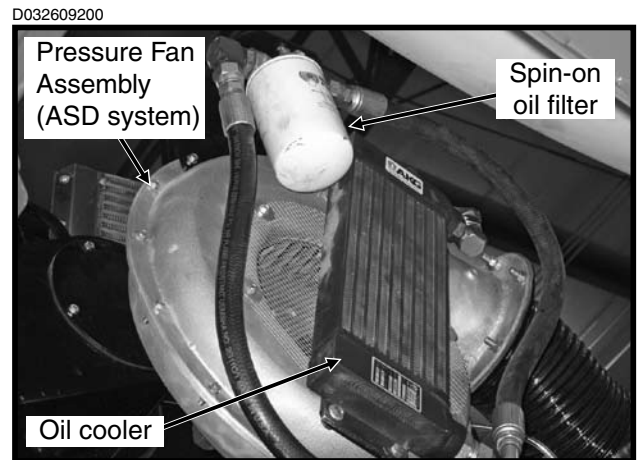
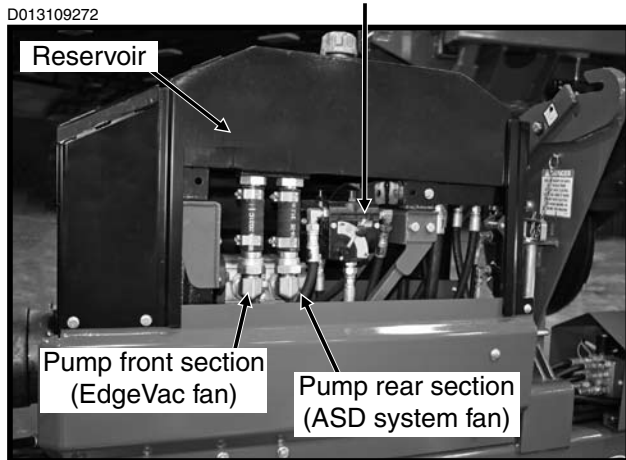

IMPORTANT: The PTO shaft coupling should be cleaned and greased each time the driveshaft is installed.

IMPORTANT: To extend life of shaft splines, apply a coating of high-pressure industrial coupling grease, such as Chevron® Coupling Grease, that meets AGMA CG-1 and CG-2 Standards.

(The Chevron® trademark is owned by Chevron Products Company. AGMA is the acronym for the American Gear Manufacturers Association)

MAINTENANCE

TRACTOR MOUNTED PTO PUMP DRIVE AND OIL COOLER OPTION

Drain the reservoir, clean strainer and change filter annually.

To drain the reservoir, disconnect the suction line (hose between reservoir and pump) from the reservoir and drain. To fully drain tank, raise the planter into field raised position. Refill system with SAE 10W-20 multigrade wide temperature range transmission hydraulic fluid. The reservoir capacity is approximately 10 gallons.

Replace filter with good quality 10 micron filter.

Start the system and allow to run with tractor at idle and the fan turned off for 1-2 minutes. Allow to run with tractor at idle and the fan at full speed for 1-2 minutes. Check reservoir fluid level and fill as required. To allow the fluid to expand when heated, the hydraulic fluid level should be within 1"-2" from the top of the reservoir after the pump has run and hydraulic hoses have been primed. Bring tractor to PTO speed and adjust flow control to the desired vacuum level using the flow control valve lever.

NOTE: Periodically check and clean oil cooler.

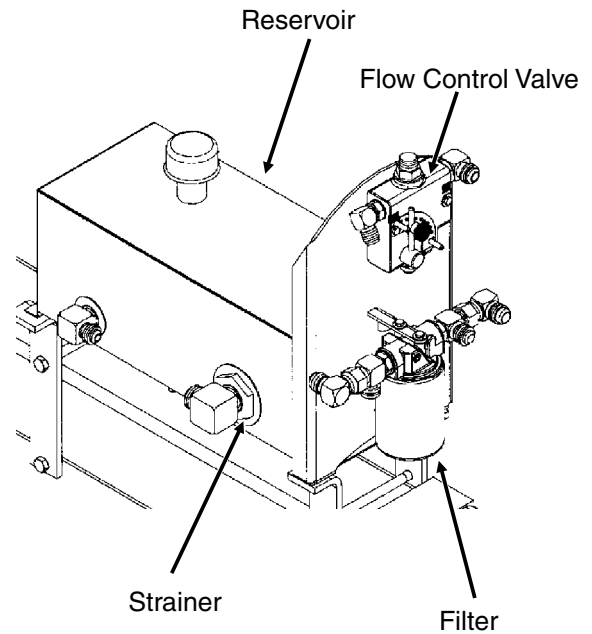

FRONT VIEW

PTO PUMP DRIVE AND OIL COOLER OPTION TROUBLESHOOTING

PROBLEM	POSSIBLE CAUSE	SOLUTION
Pump is squealing.	Lack of oil to pump.	Check for plugged suction strainer. Check oil level.
Oil temperature is high.	Low oil level.	Check oil level and add as required.
Desired fan speed cannot be achieved.	Low oil level.	Check oil level and add as required.
	Plugged filter.	Check and change as required.
Vacuum level is not displayed.	Digital vacuum gauge console power it OFF.	Turn ON.
	Cable not plugged in.	Check connection.
	Digital vacuum gauge console has no power.	Check fuse.

MAINTENANCE

CLOSING WHEEL TROUBLESHOOTING

PROBLEM	POSSIBLE CAUSE	SOLUTION
Closing wheel(s) leave severe imprint in soil.	Too much closing wheel down pressure.	Adjust closing wheel pressure.
Closing wheel(s) not firming soil around seed.	Insufficient closing wheel down pressure.	Adjust closing wheel pressure. Severe no till conditions may require use of cast iron closing wheels.
“V” closing wheel running on top of seed furrow.	Improper centering.	Align. See “V Closing Wheel Adjustment”.
Single closing wheel not directly over seed.	Improper centering.	Align. See “Covering Discs/Single Press Wheel Adjustment”.

DRAG CLOSING ATTACHMENT

LF212299-18

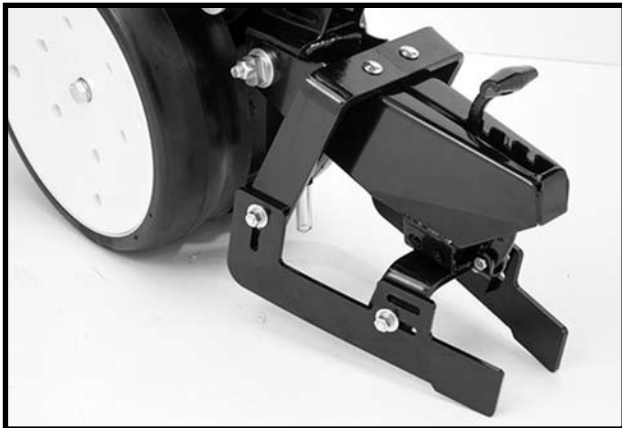

Prior to storage of the planter, inspect each drag closing attachment and replace any worn or broken parts. Check for loose hardware and tighten as needed.

Gauge Wheel Adjustment

To prevent an accumulation of dirt or trash, gauge wheels should lightly contact the opener blades. Gauge wheels and opener blades should turn with only slight resistance.

To adjust clearance between gauge wheels and opener blades, add or remove machine bushings between the shank and gauge wheel arm. Store remaining machine bushings between gauge wheel arm and flat washer on outer side of gauge wheel arm.

NOTE: It may be desirable to space gauge wheel further from blade when operating in sticky soils.

LF212199-2

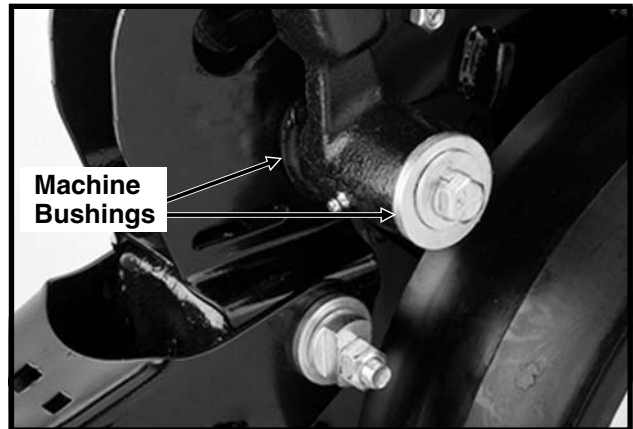

(RU113g)

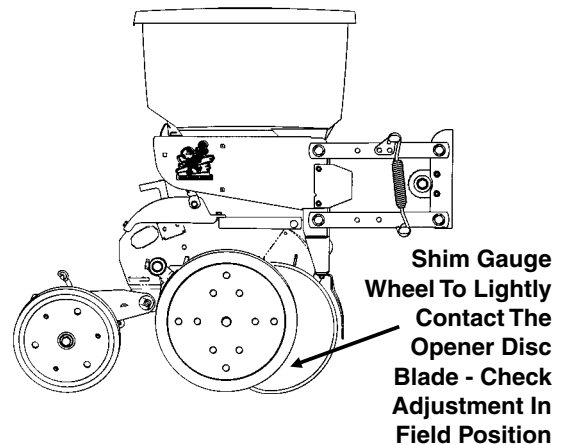

MAINTENANCE

GAUGE WHEEL ARM BUSHING AND / OR SEAL REPLACEMENT

(RU113g)

Gauge Wheel Arm Bushings/Seals

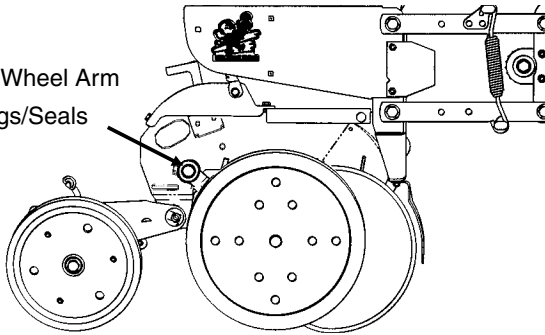

NOTE: A Gauge Wheel Arm Bushing And Seal Driver Kit (G1K296), for use in bushing and seal replacement, is available through your KINZE® Dealer.

To replace gauge wheel arm assembly bushing(s) and/or seal(s):

1. Remove gauge wheel from arm.
2. Remove the gauge wheel arm assembly from the shank assembly.
3. Remove seal and bushing and discard. Clean and dry inner bore.

(A7975/RU122)

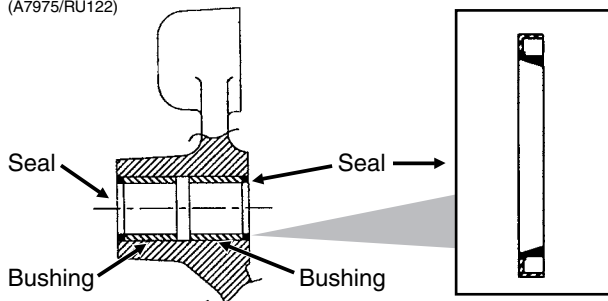

4. Drive/press replacement bushing inside bore of arm to a depth of .125" below flush.
5. Coat wiping edge of seal with grease.
6. Drive/press seal into place with lip to the outside as shown above.

NOTE: Use extra care to protect the sealing lip during installation. Apply uniform pressure to assemble the seal into the bore of the arm. Never apply a direct hammer blow to the seal surface.

7. Inspect gauge wheel pivot spindle.
8. Reinstall gauge wheel arm assembly and gauge wheel.

NOTE: Special machine bushing between gauge wheel arm and gauge wheel.

9. Shim for proper gauge wheel tire/disc blade clearance.
10. Lubricate with an SAE multipurpose grease.

GAUGE WHEEL ARM PIVOT SPINDLE REPLACEMENT

(RU113g)

Gauge Wheel Pivot Spindle

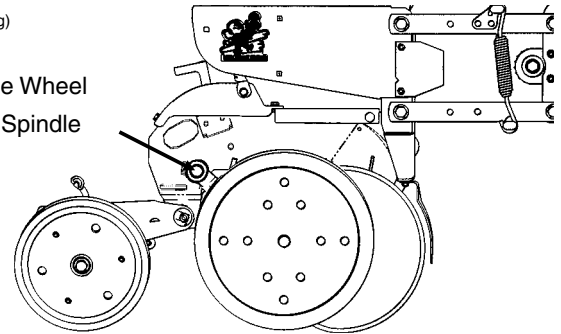

To replace gauge wheel pivot spindle:

1. Remove the gauge wheel and arm assemblies from the shank assembly.
2. Remove 1/2" x 3/4" cap screw that locks the pivot spindle in place and remove the spindle.

D06189902

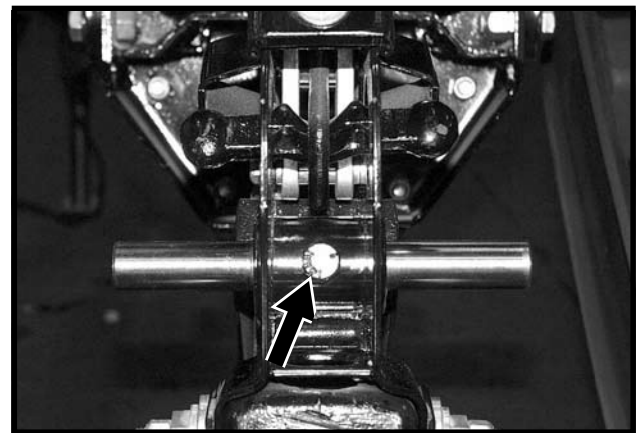

3. Install the replacement spindle and position as shown below. Exact centering is critical.

(A7966)

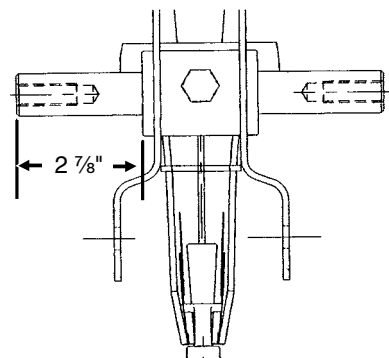

4. Install 1/2" x 3/4" cap screw and torque to lock pivot spindle in place.
5. Install gauge wheel and arm assemblies. Shim for proper gauge wheel tire/disc blade clearance.

MAINTENANCE

15" SEED OPENER DISC BLADE / BEARING ASSEMBLY

Approximately 1" - 1 ½" of blade-to-blade contact should be maintained to properly open and form the seed trench. As the blade diameter decreases, due to wear, it will be necessary to relocate machine bushings from inside to outside to maintain approximately 1" - 1 ½" of contact.

NOTE: If proper blade-to-blade contact cannot be maintained after relocating machine bushings or if blade diameter wears below 14 ½", the blades should be replaced.

IMPORTANT: Excessive blade contact may result in premature disc opener bearing/hub failures and excessive wear on seed tube guard/inner scraper. When properly adjusted, if one blade is held in fixed position, the opposite blade should be able to be rotated with minimal force (Less than 5 pounds force at outer edge of blade).

(RU113g)

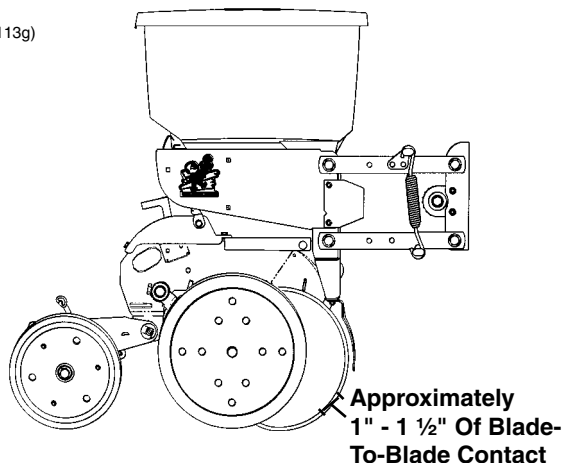

To replace disc blade/bearing assembly:

1. Remove gauge wheel.
2. Remove scraper.
3. Remove bearing dust cap.
4. Remove cap screw, washer and disc blade/bearing assembly. The machine bushings between the shank and disc blade are used to maintain the approximate 1" - 1 ½" of blade-to-blade contact.

IMPORTANT: Left hand side of opener uses a left hand threaded cap screw. DO NOT OVERTIGHTEN. Damage to shank threads will require replacement of row unit shank assembly.

5. Install machine bushing(s), new disc blade/bearing assembly, washer and cap screw. Torque ⅝"-11 Grade 5 cap screw to value shown in "Torque Values Chart".

NOTE: Replace disc blades only with disc blades of equal thickness.

6. Replace bearing dust cap.
7. Install scraper.
8. Install gauge wheel.

It may be necessary to replace only the bearing if there is excessive endplay or if the bearing sounds or feels rough when the disc blade is rotated.

To replace bearing:

1. Remove gauge wheel, scraper, bearing cap, cap screw, washer and disc blade/bearing assembly.
2. Remove ¼" rivets from bearing housing to expose bearing.
3. After installing new bearing, install three evenly spaced ¼" cap screws into three of the six holes in the bearing housing to hold the bearing and bearing housing in place. Install rivets in the other three holes. Remove ¼" cap screws and install rivets in those three holes.
4. Reinstall disc blade/bearing assembly, washer and cap screw. Torque ⅝"-11 cap screw to value shown in "Torque Values Chart" at the beginning of this section.
5. Replace bearing dust cap.
6. Install scraper and gauge wheel.

MAINTENANCE

SEED TUBE GUARD / INNER SCRAPER

The seed tube guard protects the seed tube and acts as the inner scraper for the seed opener disc blades.

Remove the seed tube and check for wear. Excessive wear on the seed tube indicates a worn seed tube guard. Replace the seed tube guard if it measures $\frac{5}{8}$ " or less at the lower end. A new seed tube guard measures approximately $\frac{7}{8}$ ".

LF212199-12

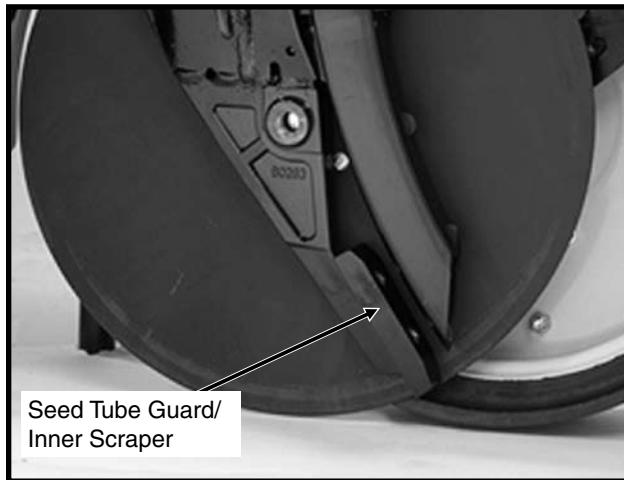

Shown With Gauge Wheel And Seed Opener Disc Blade Removed For Visual Clarity

IMPORTANT: No till planting or planting in hard ground conditions, especially when the planter is not equipped with no till coulters, and/or excessive blade-to-blade contact will increase seed tube guard wear and necessitate more frequent inspection and/or replacement.

To replace the seed tube guard, remove the seed tube and the two hex socket head cap screws which attach the seed tube guard. Hold the replacement seed tube guard centered between the seed opener disc blades. Install, but DO NOT tighten, the hex socket head cap screws. Using a clamp or vise-grip, squeeze the opener blades together in front of the seed tube guard. Tighten the seed tube guard retaining screws. Remove the clamps. The distance between the seed tube guard and opener blades should be equal on both sides. Reinstall seed tube.

IMPORTANT: Over tightening the hex socket head cap screws may damage the threads in the shank and require replacement of the shank. A seed tube guard that is worn excessively may allow the blades to wear into the row unit shank, also requiring replacement of the shank.

FRAME MOUNTED COULTER

LF083002101

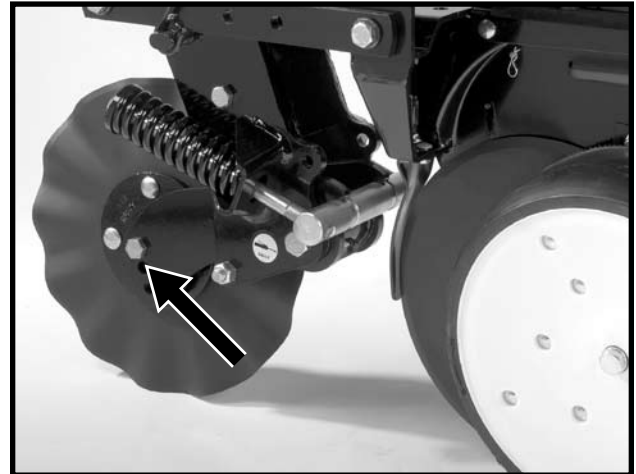

NOTE: Torque $\frac{5}{8}$ " spindle hardware to 120 ft. lbs.

See "Frame Mounted Coulters" in Row Unit Operation section of this manual for depth and spring adjustment.

When the 16" diameter coulters blade (1" fluted, 1" bubbled or $\frac{3}{4}$ " fluted) is worn to 14 $\frac{1}{2}$ " (maximum allowable wear), it should be replaced.

Residue Wheels (for use with Frame Mounted Coulters)

(RU154)

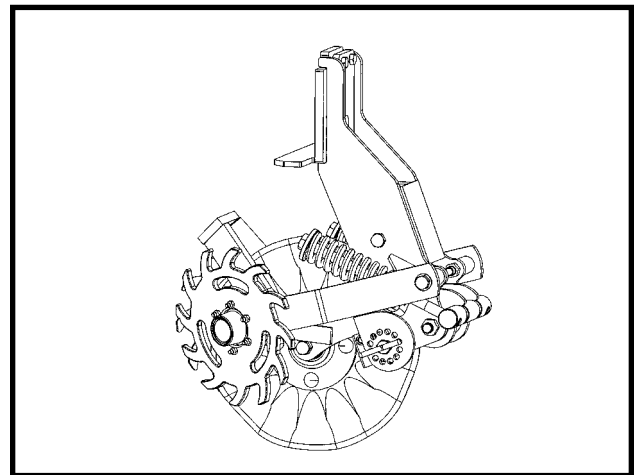

The wheel hub is equipped with sealed bearings. If a bearing sounds or feels rough when the wheel is rotated, replace the bearings.

MAINTENANCE

Row Unit Mounted Disc Furrower

LF212299-22

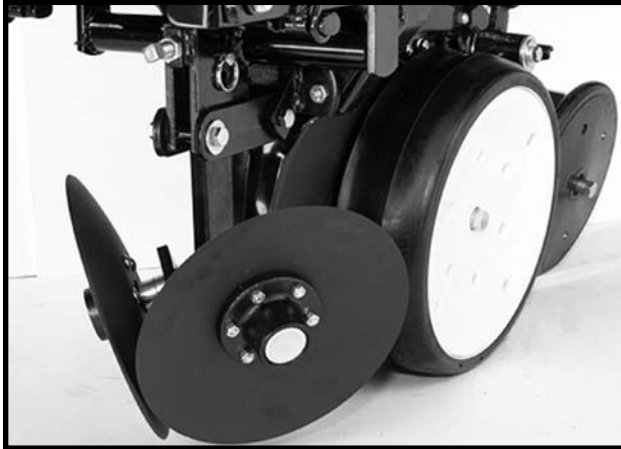

Lubricate the bushings in the support arm and mounting bracket at the frequency indicated in the Lubrication Section of this manual. Using a torque wrench, check each bolt for proper torque. If the bolt is loose, it should be removed and the bushing inspected for cracks and wear. Replace bushings as necessary. **Only hardened flat washers should be used. Replace damaged flat washers with proper part. Torque cap screws to 57 ft. lbs.**

The blade hubs are equipped with sealed bearings. If bearings sound or feel rough when the blade is rotated, replace the bearings.

When the 12" diameter blades (solid or notched) are worn to 11", they should be replaced.

ROW UNIT MOUNTED BED LEVELER

LF212299-25a

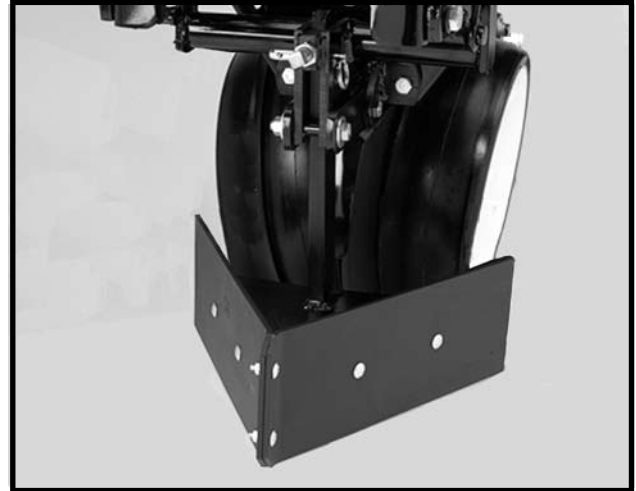

59386-26

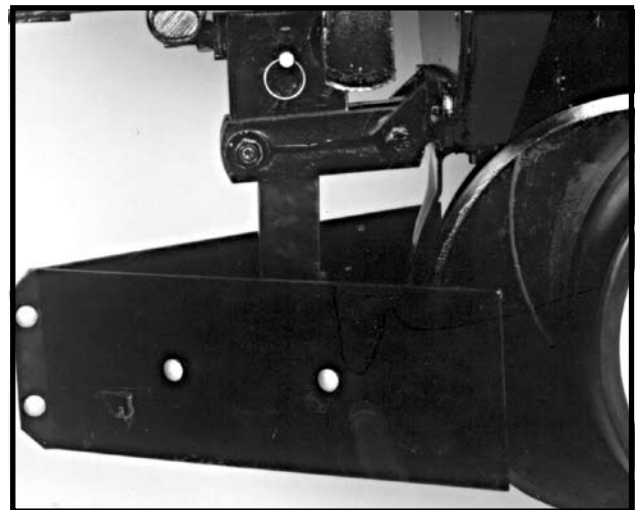

Lubricate the bushings in the mounting bracket and links at the frequency indicated in the Lubrication Section of this manual. Using a torque wrench, check each bolt for proper torque. If the bolt is loose, it should be removed and the bushing inspected for cracks and wear. Replace bushing if necessary. **Only hardened flat washers should be used. Replace damaged flat washers with proper part. Torque hardware to 130 ft. lbs.**

MAINTENANCE

ROW UNIT MOUNTED RESIDUE WHEEL

(A12685)

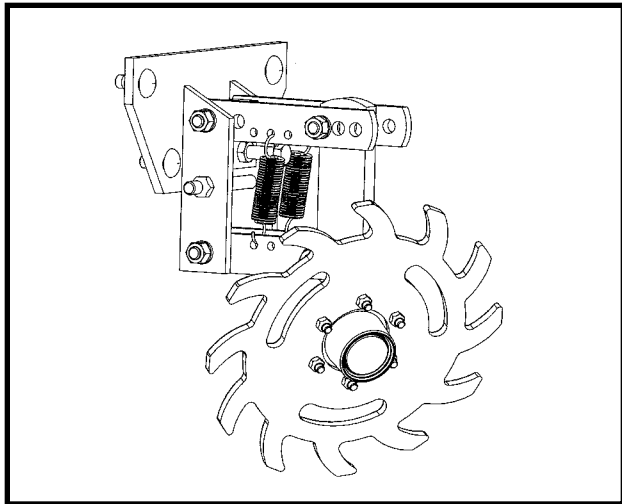

The wheel hub is equipped with sealed bearings. If a bearing sounds or feels rough when the wheel is rotated, replace the bearings.

ROW UNIT MOUNTED NO TILL COULTER

D05170706a

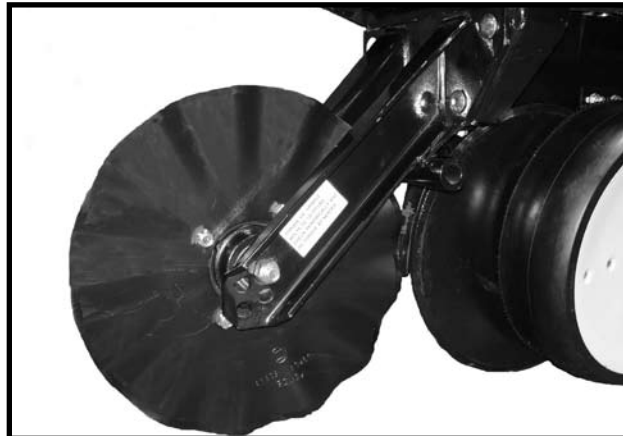

Check periodically to be sure nuts and hardware are tightened to proper torque specification.

NOTE: Torque $\frac{5}{8}$ " spindle hardware to 120 ft. lbs.

Be sure the coulters are positioned square with the row unit and aligned in front of row unit disc opener.

The coulters blade can be adjusted to one of four settings. Initially the blade is set in the highest position. As the blade wears it can be adjusted to one of the three lower settings. See "Row Unit Mounted No Till Coulters" in Row Unit Operation section of this manual.

When the 16" diameter coulters blade is worn to 14 $\frac{1}{2}$ " (maximum allowable wear), it should be replaced.

COULTERS MOUNTED RESIDUE WHEELS

D05170708a



The wheel hubs are equipped with sealed bearings. If bearings sound or feel rough when the wheel is rotated, replace the bearings.

MAINTENANCE

GRANULAR CHEMICAL ATTACHMENT

Prior to storage of the planter, disengage the granular chemical drive by rotating the throwout knob $\frac{1}{4}$ turn counterclockwise. Remove the drive chain and empty and clean all granular chemical hoppers. Clean the drive chains and coat them with a rust preventive spray or submerge chains in oil. Inspect and replace any worn or broken parts.

Install hoppers and chains. Check chain alignment.

LF212299-4

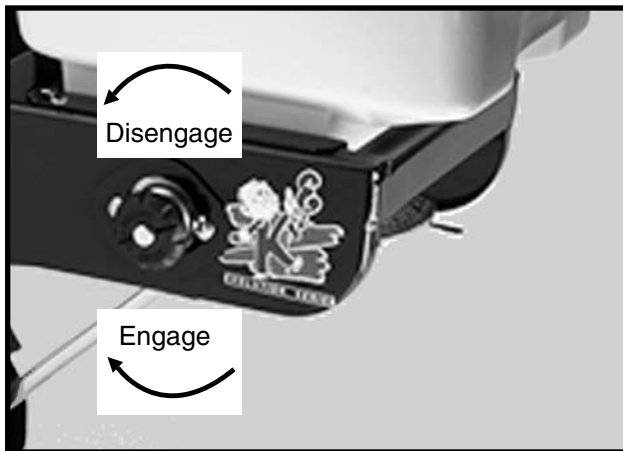

SPRING TOOTH INCORPORATOR

Prior to storage of the planter, inspect each spring tooth incorporator and replace any worn or broken parts. Check for loose hardware and tighten as needed.

LF212299-26

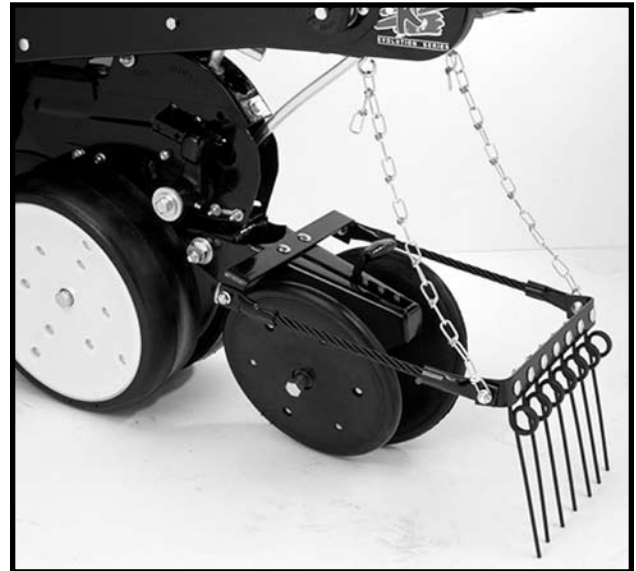

MAINTENANCE

CHECK VALVE INSPECTION (LOCATED IN VALVE BLOCK BELOW VACUUM FAN MOTOR ASSEMBLY)

(TWL24b)

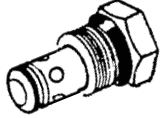

The check valve operates as a check in the return line to prevent reverse operation of the vacuum fan motor. If the valve fails to function properly, it should be removed for inspection. Check for foreign material or check to see if the o-ring is leaking internally. Replace if found to be defective.

CHECK VALVE

(TWL30)

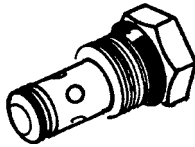

The check valves, located in the valve block on the right side of the center post, trap oil flow in the planter's lift system to keep the toolbar level during field operation. Consult your KINZE® Dealer for service.

RELIEF VALVE CARTRIDGE INSPECTION (LOCATED IN VALVE BLOCK BELOW VACUUM FAN MOTOR ASSEMBLY)

(A11340)



The pressure relief valve helps prevent damage to the vacuum fan motor by limiting pressure in the motor case drain line. It is set to open at 35 PSI. If the valve fails to function properly, it should be removed for inspection. Check for foreign material and contamination on both the valve and the seating area of the valve body. Replace if found to be defective.

FLOW CONTROL VALVE INSPECTION

VVB020(TWL28)

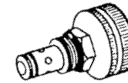

The flow control valves should be adjusted for row marker raise and lower speed as part of the assembly procedure or upon initial operation. If the valve fails to function properly or requires frequent adjustment, it should be removed for inspection. Check for foreign material and contamination on both the valve and the seating area of the valve body. Replace any components found to be defective.

PRESSURE RELIEF VALVE INSPECTION

VVB020(TWL29)

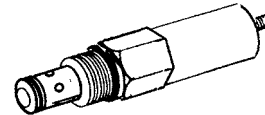

If the pressure relief valve fails to release the tongue lock or function properly, remove the valve from the valve block and check for foreign material or check to see if the O-ring is leaking internally. Replace if found to be defective.

PRESSURE REDUCING / RELIEVING VALVE INSPECTION

(A13034)

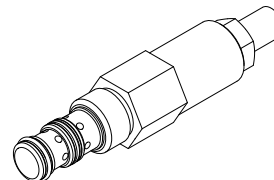

Improper function of wing down force system could be caused by misadjusting/sticking. Remove the valve from the valve block and check for foreign material or check to see if the O-ring is leaking internally. Replace if found to be defective.

MAINTENANCE

SOLENOID VALVE INSPECTION

VVB019(PLTR55)

The solenoid valve consists of a chambered body containing a cartridge valve which is activated by an electrical coil.

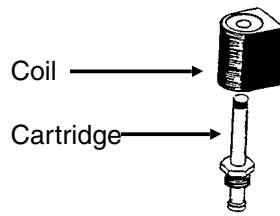

If the solenoid or solenoids fail to operate, first determine if the problem is electrical or hydraulic. If the valve is working properly, a click will be heard when the solenoid coil is energized. This will be the valve stem opening up. If no sound is heard, check the solenoid coil by touching the top of the coil housing with a metallic object such as a pliers or screwdriver. If the coil is working properly, the coil housing will be strongly magnetized when energized. If the voltage to the coil is low, the coil will be weakly magnetized when energized and no click will be heard.

SOLENOID VALVE TROUBLESHOOTING

PROBLEM	POSSIBLE CAUSE	SOLUTION
None of the solenoids will operate.	Low voltage.	Must be connected to 12 volt DC only. Negative ground.
	Blown fuse.	Replace fuse in control console on tractor with AGC-15 amp only.
	Battery connection.	Clean and tighten.
	Wiring harness damaged.	Repair or replace.
One solenoid valve will not operate.	Bad switch.	Replace on control panel.
	Cut wire in harness.	Locate and repair.
	Bad coil.	Replace.
	Poor connection at coil.	Check.
Valve operating when not energized.	Valve stem stuck open.	Replace cartridge.
	O-ring leaking.	Install new O-ring kit.
	Foreign material under poppet.	Remove cartridge and clean.

MAINTENANCE

LIFT CIRCUIT TROUBLESHOOTING

PROBLEM	POSSIBLE CAUSE	SOLUTION
Right wing raises faster than left wing. The right wing may even raise completely before the rock shaft and left wing start to raise. If the planter is loaded, the rock shaft and left wing may not be able to raise at all.	Master cylinder, located on right side of rock shaft, leaking internally. NOTE: Make sure the lift system is completely rephased.	Repair master cylinder.
Left wing raises faster than right wing. The left wing may even raise completely before the rock shaft and right wing start to raise. If the planter is loaded, the rock shaft and right wing may not be able to raise at all.	Master cylinder, located on left side of center post, leaking internally. NOTE: Make sure the lift system is completely rephased.	Repair master cylinder.
Rock shaft will raise, but wings do not.	Planter hydraulic circuit out of phase. Usually occurs when the planter is lowered from transport position.	Hold hydraulic control in lowering position to give the hydraulic circuit more time to rephase.
Planter will not raise or raises slowly.	Tractor may have hydraulic problem.	Switch remote outlets being used. Repair tractor hydraulics.
	Planter may be overloaded with hopper extensions and/or extra fertilizer tanks, coulters or other non-KINZE® attachments.	Remove weight.
Planter will not rephase.	All cylinders not completely retracted. Caused by mechanical interference on or between planter frame and wheel lift module.	Remove interference.
	Center cylinders not retracting completely.	Lower planter and hold hydraulic lever in lower position to rephase system. Lower cylinder pins must be free to rotate in this position. If pins are tight, adjust cylinder clevises.

MAINTENANCE

TONGUE CYLINDER CIRCUIT TROUBLESHOOTING

PROBLEM	POSSIBLE CAUSE	SOLUTION
Tongue cylinder will not extend, but will retract.	No power to solenoid valve coil in port V10 and/or V14. Both must be energized.	Check wiring between control console and solenoid coils looking for damaged wires and poor connections.
	Solenoid valve coil defective.	Switch coil from port V13 with V10. If tongue still will not extend, switch coil from V14 with V13. It will not be necessary to remove any of the wire connections to the solenoid. All three of these solenoids are normally energized when the tongue switch is energized. Replace defective coil.
	Solenoid valve cartridges in port V10 and/or V14 stuck closed.	Switch cartridge from port V10 with cartridge in port V13. If tongue cylinder retracts, replace defective cartridge from port V10. If problem continues, switch cartridge from port V14 with cartridge in port V13. Replace defective cartridge.
Tongue cylinder will not extend but tongue lock cylinder extends.	Pressure relief valve in port V11 stuck closed or pressure setting too high. (Valve is factory set to open at 1000 PSI.)	Replace or adjust pressure relief valve. To adjust, loosen lock nut and turn counter clockwise to decrease pressure.
Tongue hook does not release before the tongue starts to extend.	Solenoid valve cartridge in port V11 stuck open or pressure setting too low. (Valve is factory set to open at 1000 PSI.)	Replace or adjust pressure relief valve. To adjust, loosen lock nut and turn clockwise to increase pressure.
Tongue cylinder will not retract, but will extend.	Solenoid valve coil in port V13 defective.	Switch coil from port V13 with coil from port V14. If coil from port V13 is bad, the tongue will extend but not retract. Replace defective coil.
	Solenoid valve cartridge in port V13 stuck closed.	Switch cartridge from port V13 with cartridge from port V14. If cartridge is bad, the tongue will extend but not retract. Replace defective cartridge.
Tongue extends with the switch off.	Solenoid valve cartridge in port V10 and V14 stuck open.	Replace solenoid valve cartridge.
Tongue retracts with the switch off.	Solenoid valve cartridge in port V13 stuck open.	Replace solenoid valve cartridge.
Tongue latch releases. Tongue extends slowly while planting.	Latch cylinder or tongue cylinder leaking internally.	Pressure check latch and tongue cylinders. Repair leaking cylinder(s).

MAINTENANCE

ROTATION CYLINDER CIRCUIT TROUBLESHOOTING

PROBLEM	POSSIBLE CAUSE	SOLUTION
Cylinder does not extend, but will retract.	Solenoid valve coil in port V12 defective.	Switch coil from port V12 with coil in port V9. If cylinder extends but will not retract, replace defective coil from port V12.
	Solenoid valve cartridge in port V12 is stuck closed.	Switch cartridge from port V12 with cartridge in port V9. If cylinder extends but will not retract, replace defective cartridge from port V12.
Cylinder does not retract, but will extend.	Solenoid valve coil in port V9 defective.	Switch coil from port V9 with coil in port V12. If cylinder extends but will not retract, replace defective coil from port V9.
	Solenoid valve cartridge in port V9 is stuck closed.	Switch cartridge from port V9 with cartridge in port V12. If cylinder extends but will not retract, replace defective cartridge from port V9.

WING LOCK CYLINDER CIRCUIT TROUBLESHOOTING

PROBLEM	POSSIBLE CAUSE	SOLUTION
Cylinders will not extend or retract.	No power to the solenoid valve coils.	Check fuse at control console. Replace fuse with 15 amp type AGC if blown. Check for poor wire connection or damaged wire. Repair as required.
Cylinders will not extend.	Solenoid valve coil in port V3 not energized.	Check for power to coil. Check coil ground wire. If OK, switch coil from port V3 with coil from port V4. If cylinders extend but will not retract, replace defective coil.
	Solenoid valve cartridge in port V3 stuck closed.	Switch cartridge in port V3 with cartridge in port V4. If cylinders extend but will not retract, replace defective cartridge.
Cylinders will not retract.	Solenoid valve coil in port V4 not energized.	Check for power to coil. Check coil ground wire. If OK, switch coil from port V4 with coil from port V3. If cylinders retract but will not extend, replace defective coil.
	Solenoid valve cartridge in port V4 stuck closed.	Switch cartridge in port V4 with cartridge in port V3. If cylinders retract but will not extend, replace defective cartridge.
Cylinders retract with the switch off.	Solenoid valve cartridge in port V4 stuck open.	Replace solenoid valve cartridge.
Cylinders extend with the switch off.	Solenoid valve cartridge in port V3 stuck open.	Replace solenoid valve cartridge.

MAINTENANCE

ROW MARKER OPERATION TROUBLESHOOTING

PROBLEM	POSSIBLE CAUSE	SOLUTION
Right marker lowering slower than left marker.	Solenoid valve cartridge in port V1 or V9 not opening completely.	Switch cartridge with one in port V2. If problem follows cartridge, replace cartridge.
	Hose pinched or collapsed.	Inspect hose routing. Replace or repair hoses as required.
Left marker lowering slower than right marker.	Solenoid valve cartridge in port V2 or V10 not opening completely.	Switch cartridge with one in port V1. If problem follows cartridge, replace cartridge.
	Hose pinched or collapsed.	Inspect hose routing. Replace or repair hoses as required.
Both markers lowering.	Solenoid valve cartridge stuck open. If marker switch is in the left marker position, the right cartridges (V1 and V9) are defective. If the marker switch is in the right marker position, the left cartridges (V2 and V10) are defective.	Replace solenoid valve cartridge.
Neither marker will lower.	Blown fuse.	Check red light on control console. It should be on if switch is on. If light is not on, switch to opposite marker position. If light comes on, switch may be defective. Replace switch. Otherwise replace fuse.
	Coils at V1, V9 and V2, V10 not energized.	Poor ground on wire, bad wire connection or damaged wire. Repair as required.
	Marker flow control valve closed too far.	See Operation Section for adjustment.
Neither marker will raise.	Marker flow control valve closed too far.	See Operation Section for adjustment.
Right marker will not lower.	Solenoid coil in port V1 or V9 not energized.	Check switch on control console. Replace if defective. Check coil ground wire. Check for poor connection or damaged wire.
	Solenoid cartridge in port V1 or V9 stuck closed.	Switch cartridge with one on the planter you know is operating properly. If right marker lowers, replace defective cartridge.
Left marker will not lower.	Solenoid coil in port V2 or V10 not energized.	Check switch on control console. Replace if defective. Check coil ground wire. Check for poor connection or damaged wire.
	Solenoid cartridge in port V2 or V10 stuck closed.	Switch cartridge with one on the planter you know is operating properly. If left marker lowers, replace defective cartridge.
Markers traveling too fast and damaging rubber stop on transport stands and/or damaging pivot at rod end of marker cylinders.	Marker transport stand not adjusted correctly to allow marker cushion cylinders to operate as designed.	See "Row Marker Transport Stand Adjustment".
	Marker flow control valve out of adjustment.	See Operation Section for adjustment.

MAINTENANCE

ROW MARKER BEARING LUBRICATION OR REPLACEMENT

1. Remove marker blade.
2. Remove dust cap from hub.
3. Remove cotter pin, nut and washer.
4. Slide hub from spindle.
5. Remove bearings and cups and discard if bearings are being replaced. Clean hub and dry. Remove bearings only and not cups if repacking.
6. Press in new bearing cups with thickest edge facing in. (Bearing replacement procedure only.)
7. Pack bearings with heavy duty wheel bearing grease thoroughly forcing grease between roller cone and bearing cage. Also fill the space between the bearing cups in the hub with grease.
8. Install rubber seal into grease seal. Place inner bearing in place and press in new rubber seal/grease seal.
9. Clean spindle and install hub.
10. Install outer bearing, washer and slotted hex nut. Tighten slotted hex nut while rotating hub until there is some drag. This assures that all bearing surfaces are in contact. Back off slotted nut to nearest locking slot and install cotter pin.
11. Fill dust caps approximately $\frac{3}{4}$ full of wheel bearing grease and install on hub.
12. Install blade and dust cap retainer on hub and tighten evenly and securely.

(TP1012PLTR99/PLTR98/PLTR102)

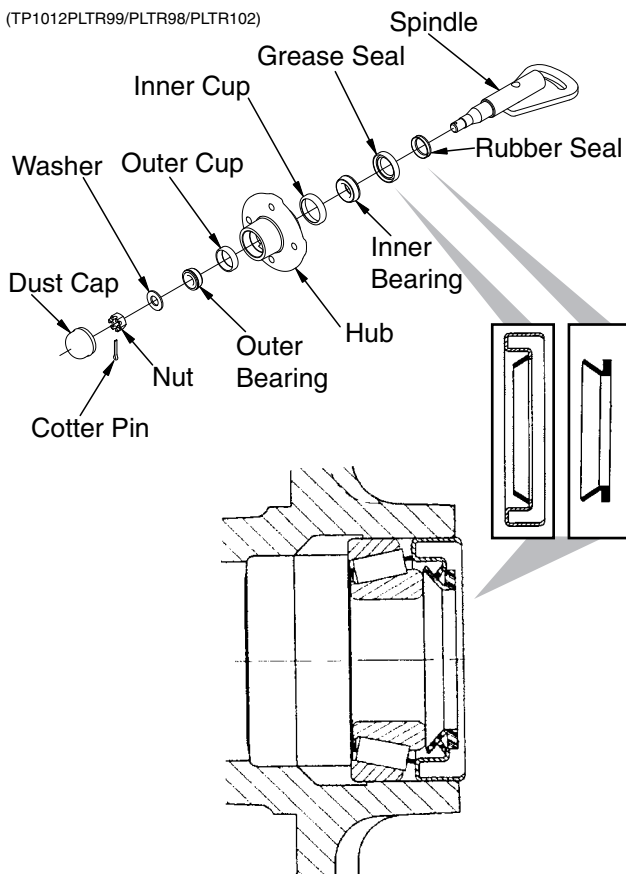

[Return to Table of Contents](#)

WHEEL BEARING LUBRICATION OR REPLACEMENT

NOTE: Each transport wheel hub is equipped with a grease fitting for lubrication. The below procedure is used only for bearing replacement.

1. Raise tire clear of ground and remove wheel.
2. Remove double jam nuts and slide hub from spindle.
3. Remove bearings, seals (Where Applicable) and cups and discard if bearings are being replaced. Clean hub and dry. Remove bearings only and not cups if repacking.
4. Press in new bearing cups with thickest edge facing in. (Bearing replacement procedure only.)
5. Pack bearings with heavy duty wheel bearing grease thoroughly forcing grease between roller cone and bearing cage. Also fill the space between the bearing cups in the hub with grease.
6. Place inner bearing and seal (If Applicable) in place.
7. Clean spindle and install hub.
8. Install outer bearing, seal (If Applicable) and stepped nut. Tighten jam nut while rotating hub until there is some drag. This assures that all bearing surfaces are in contact. Back off jam nut $\frac{1}{4}$ turn or until there is only slight drag when rotating the hub. Install second jam nut to lock against first.
9. Install wheel on hub and tighten evenly and securely. Torque wheel bolts to specified torque.

(EF35e/PLTR56)

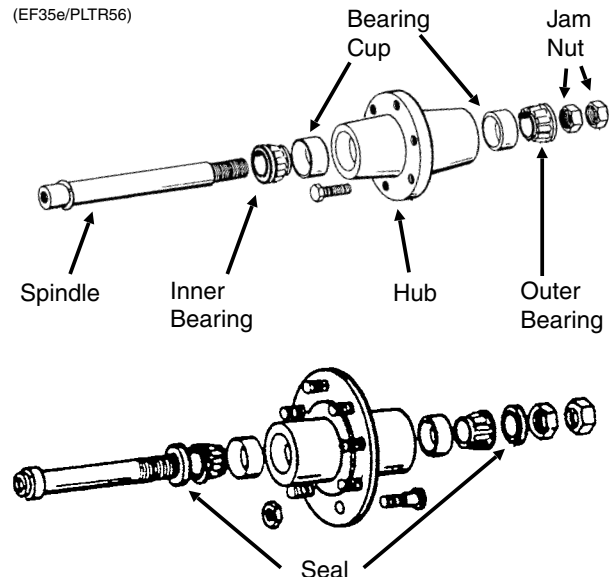

MAINTENANCE



DANGER: Always engage all safety lockup devices or lower planter to ground before working under or around machine.

The 3660 planter includes a center frame section that slides up and down on a central 7" x 7" tube to move between transport and operation positions. Part of the center frame is a slide assembly consisting of four wear pad assemblies, which ride against the powder coated center tube, held in place by 3/4" set screws and jam nuts.

Inspect and adjust the wear pads annually to ensure planter frame is stable and planter tracks correctly. When properly adjusted, wear pads should lightly make full contact with center post. Excessive preload on pads will cause increased hydraulic lift pressure and possibly fail to lift planter when fully loaded.

ROCKSHAFT TO HITCH SHIM ADJUSTMENT

STEP 1 Set rockshaft cylinder mount distance.

Install strap fixture at rockshaft cylinder location to establish 26" center-to-center cylinder mount distance.

D0224091

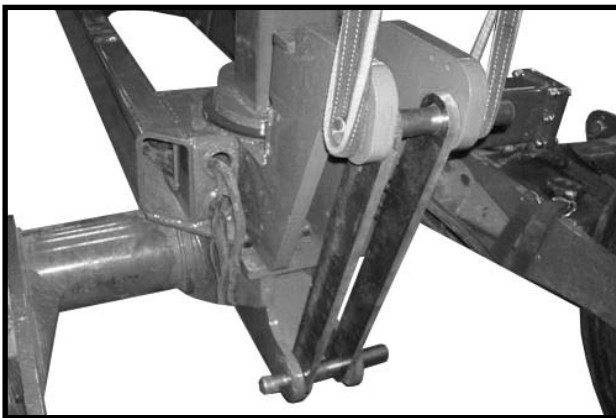

STEP 2 Adjust rockshaft shim stack.

With the 1/4" thick wear plate on top, and using a combination of 16 gauge and 10 gauge shims, install a suitable shim stack to maintain 26" distance.

D09040902

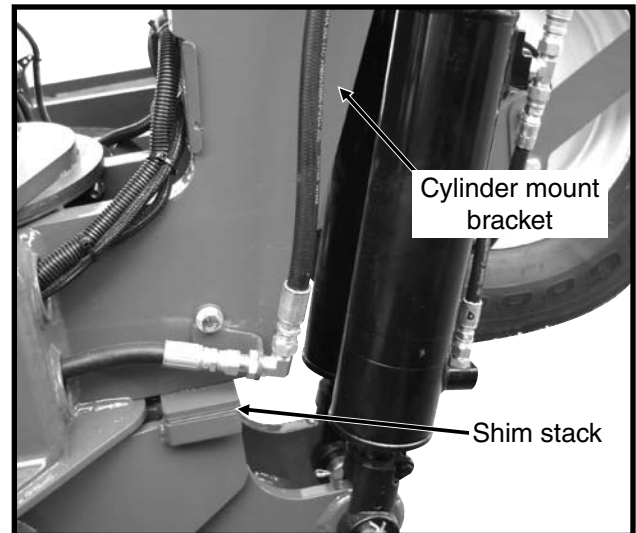

CENTER FRAME RELATION TO INNER HITCH ADJUSTMENTS

IMPORTANT: Planter must be in transport position with safety stand installed and rock shaft cylinders fully retracted.

STEP 1 Fully raise planter.

Lock wing frames for transport and fully raise planter. Install safety stand at center post as shown. Make sure top latch is around cylinder rod and fastened with safety pin, and that lower end is secured with detent pin.

D013009209

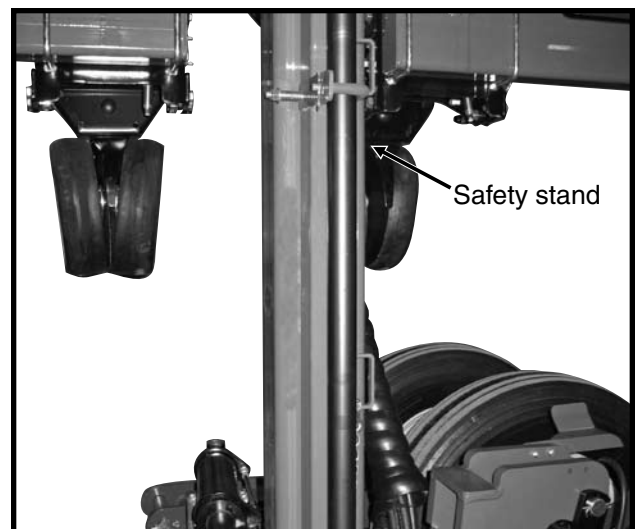

MAINTENANCE

STEP 2 Adjust lower wear pads.

Loosen jam nuts. Loosen and tighten set screws to move center frame slide tube until distance from outside of center tube to outside of slide tube is equal on all four sides - approximately 1½". Tighten all eight set screws.

STEP 3 Set contact pressure of lower wear pads.

IMPORTANT: Perform the following operation one set screw at a time.

Loosen set screw, and then tighten set screw to 20 ft-lbs. While holding set screw with a wrench to prevent it from turning, tighten jam nut to 75 ft-lbs. Complete operation to all eight set screws.

D013009208



Bottom of slide - six set screws

D013009223

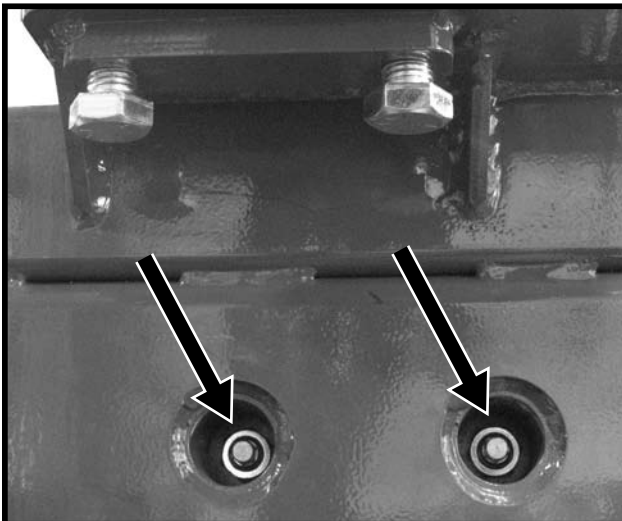

Rear side of planter - two set screws

[Return to Table of Contents](#)

STEP 4 Lower planter frame.

Remove center post safety stand; lower planter frame until approximately 2' above top surface of outer hitch. Turn off hydraulic power source.

STEP 5 Measure from outer hitch to center frame.

The top surface of outer hitch must be parallel to the bottom of the center frame. To establish this, the distance between them is measured at four points:

- Top front of inner hitch to bottom of center sub-frame – left and right sides.
- Top rear of inner hitch to bottom of center frame – left and right sides.

NOTE: Subtract 8" from front measurement values before comparing to rear values.

To measure distances:

1. Place a 2" x 2" x 36" tube, or other suitable straight object, on top of one leg of inner hitch, behind shim stack, as shown.
2. Measure at points indicated above.
3. Repeat on other leg of inner hitch.

D022709200

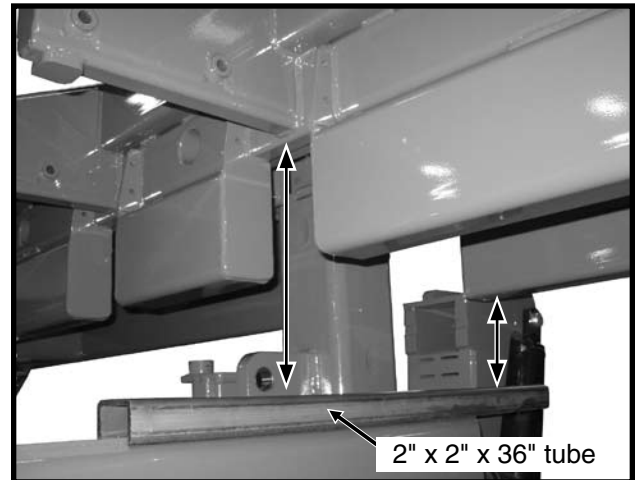

MAINTENANCE

STEP 6 Adjust upper wear pads.

NOTE: Performing this operation will require repeating STEP 5 until desired results are achieved.

Loosen jam nuts. Loosen and tighten set screws until all four measurements in STEP 5 are equal.

Tighten all eight set screws.

STEP 7 Set contact pressure of upper wear pads.

IMPORTANT: Perform the following operation one set screw at a time.

Loosen set screw, and then tighten set screw to 20 ft-lbs. While holding set screw with a wrench to prevent it from turning, tighten jam nut to 75 ft-lbs. Complete operation to all eight set screws.

D013009200

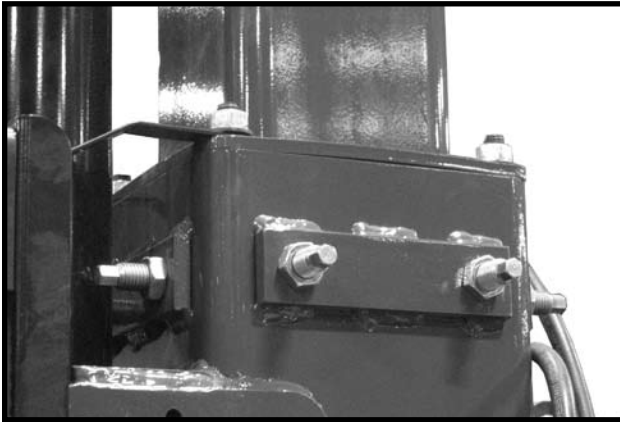

D013009201

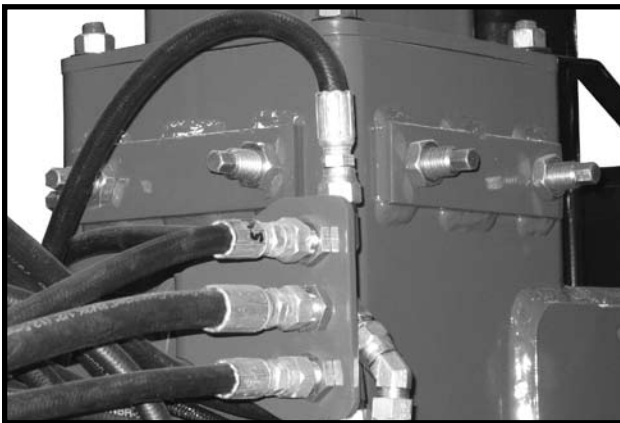

STEP 8 Remove inner hitch and field stabilizer shims.

In preparation of adjusting shim stack thicknesses, some shims must be removed to preventing pre-loading of planter frame.

Loosen fasteners and remove one or two shims from the following locations:

- Inner hitch shim stack – left and right sides.
- Field stabilizer shim stack – left and right sides.

Replace fasteners at field stabilizers to keep shim stack in place.

D013009212

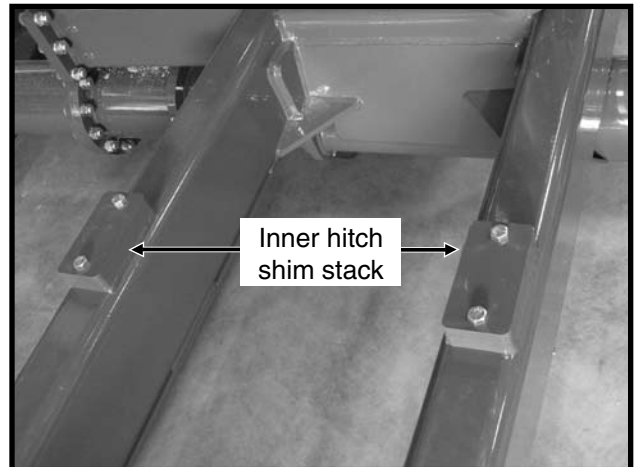

D013009217

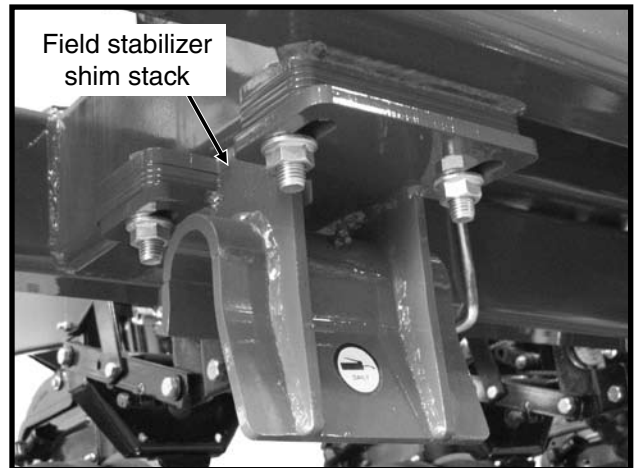

MAINTENANCE

STEP 9 Raise landing pad bolts.

Also, in preparation of adjusting shim stack thicknesses, the landing pad bolts must be raised. Loosen jam nuts and thread in bolts several turns.

D013009223

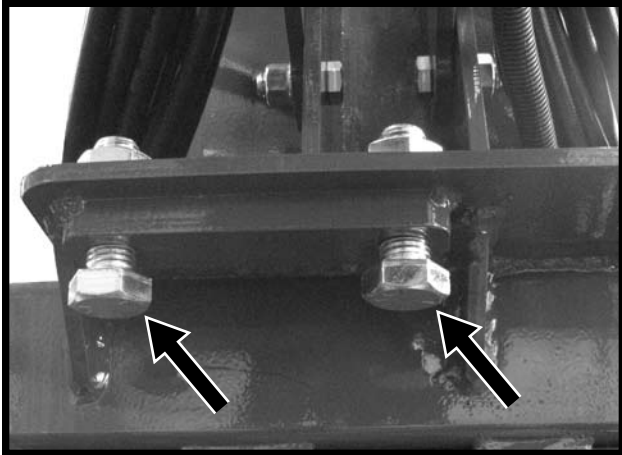

STEP 10 Lower planter onto temporary shims.

Make two $\frac{3}{16}$ " x 2" x 1" shims out of bar stock or other suitable material.

Place one shim on left and one shim on right side of center post flange. Lower planter until center frame slide rests on them.

NOTE: When planter is lowered, no planter frame weight is to be supported at shim stacks or landing pad bolts – there must be space for adding shims and adjusting bolts downward.

D022709201

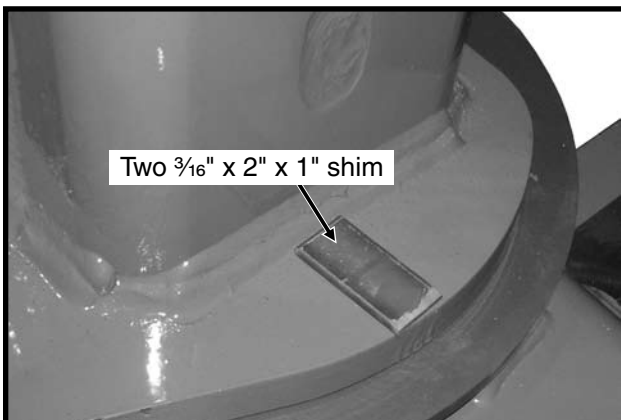

STEP 11 Add shims to shim stacks.

NOTE: It is important to fully fill open space with appropriate combination of shims. Tolerance for filling open space is $+0.030$ " / -0.000 ".

Add shims to fill open space at the following locations:

- Inner hitch shim stack – left and right sides; make sure $\frac{1}{4}$ " thick wear plates remain on top.
- Field stabilizer shim stack – left and right sides.

After adding shims, shim stack fasteners on inner hitch may be tightened. DO NOT fully tighten fasteners at field stabilizers.

Raise planter on center post, remove temporary shims from beneath center frame slide, and then fully lower planter.

STEP 12 Adjust landing pad bolts.

Lower landing pad bolts until they touch landing pad; hold in place with wrench to prevent turning and tighten jam nuts.

TRIANGULATE PLANTER AND SET SQUARENESS

IMPORTANT: Planter frame must be square with hitch frame to ensure planter tracks correctly during operation.

STEP 1 Remove rotation stop block.

Raise planter to transport position and install safety stand. Loosen fasteners; remove stop tap block and shims. Remove safety stand and fully lower planter.

D013009237



MAINTENANCE

STEP 2 Establish reference marks.

Measure 67" from left side of inner hitch along lower frame member of center frame; place reference mark with an appropriate marker. Repeat on right side.

Measure width of inner hitch, divide value by 2, measure from one side of hitch, and place a centerline reference mark at that point on upper hitch cross member.

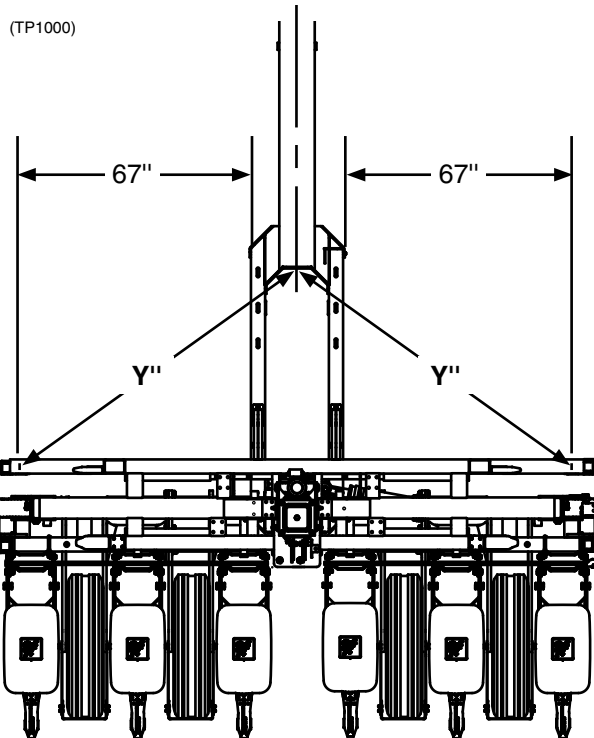

STEP 3 Check squareness of planter.

Measure from centerline to each of the reference marks on center frame (Y").

- If measurements are NOT equal, adjustment is required – see STEP 4.
- If measurements are equal, no adjustment is necessary – see STEP 5.

STEP 4 Adjust squareness of planter.

1. Rotate center post or push on end of planter frame with the shorter distance.
2. Re-measure from centerline to reference marks.
3. Repeat until measurements are equal.

STEP 5 Lock down squareness of planter.

When measurements are equal on both sides of planter, tighten field stabilizer fasteners.

D013009217

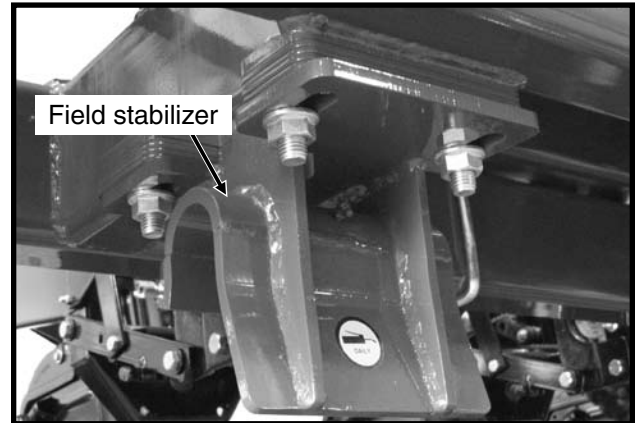

ROTATION STOP BLOCK - INSTALL

STEP 1 Measure for required stop block thickness.

Raise planter to transport position and install safety stand.

Measure distance between stop mount on inner hitch, and stop surface on center post. Include stop tap block and determine the required combination of shims to completely fill this space. The tolerance for filling the space is $+1/16$ " / -0 ".

D013009237a

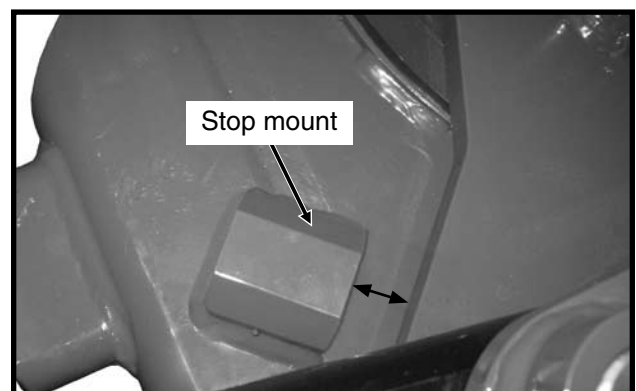

MAINTENANCE

STEP 2 Install shims and stop tap block.

Rotate center post slightly to provide room to install shims.

NOTE: In situations where few shims are required, the attachment cap screws may protrude beyond the stop tap block. Install shims beneath cap screw heads to prevent them from protruding.

Attach required shims and stop tap block using two $\frac{3}{8}$ "-16 x 3" cap screws.

Rotate center post against stop block.

D013009237

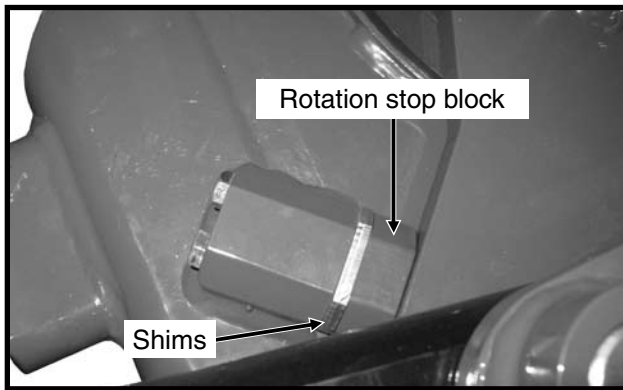

INSPECT AND ADJUST ROTATION CYLINDER MOUNT

STEP 1 Inspect that cylinder is correctly retracted.

Make sure center post is rotated against stop block. Inspect rotation cylinder for correct amount of retraction.

- A correctly retracted cylinder will have $\frac{1}{16}$ " or less exposed sliding surface on the rod .
- If cylinder has more than $\frac{1}{16}$ " sliding surface exposed, shims will need to be removed from cylinder mount.
- If cylinder has no slide surface exposed, AND the center post cannot be fully rotated against stop block, then shims will need to be added to cylinder mount.

D013009236

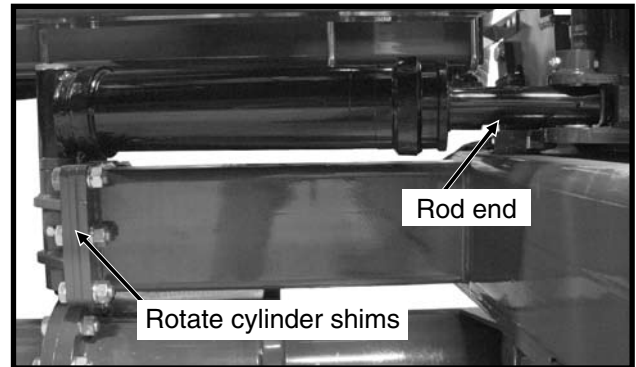

STEP 2 Adjust rotation cylinder mount.

Disconnect rod end of cylinder and remove six sets of fasteners from cylinder mount. Add or subtract shims as necessary.

Reassemble cylinder mount and connect rod end of cylinder. Inspect for correct amount of retraction.

D013009236

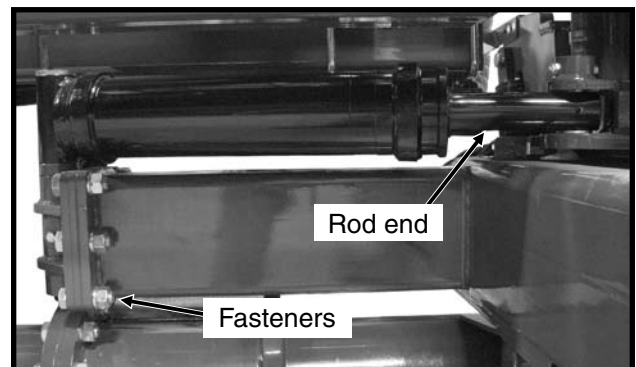

MAINTENANCE

PISTON PUMP STORAGE

IMPORTANT: KEEP AIR OUT OF PUMP! This is the only way to prevent corrosion. Even for short periods of storage, the entrance of air into the pump, will cause RAPID AND SEVERE CORROSION.

Overnight Storage

SUSPENSION FERTILIZER must be flushed from the pump for ANY storage period.

Winter Storage

1. Flush pump thoroughly with 5 to 10 gallons of fresh water and circulate until all corrosive salts are dissolved in the pump.
2. With the pump set on 10, draw in a mixture of half diesel fuel and half 10 weight oil until the discharge is clean. Then plug inlet and outlet.

NGP6055



PISON PUMP TROUBLESHOOTING

PROBLEM	POSSIBLE CAUSE	SOLUTION
Pump hard or impossible to prime.	Valves fouled or in wrong place.	Inspect and clean valves.
	Air leak in suction line.	Repair leak.
	Pump set too low.	Adjust pump setting.
	Packing washers worn out.	Replace.
Low metering.	Valves fouled or in wrong place.	Inspect and clean valves.
	Air leak in suction line.	Repair leak.
	Pump set too low.	Adjust pump setting.
	Broken valve spring.	Replace spring.
Over meters.	Broken discharge valve spring.	Replace spring.
	Trash under valves.	Inspect and clean valves.
	Improper rate setting.	Adjust pump setting.
Leaks through when stopped.	Broken discharge valve spring.	Replace spring.
	Trash under valves.	Inspect and clean valves.
Fertilizer solution leaking under stuffing box.	Packing washers worn out.	Replace.
Pump using excessive oil.	Oil seals or O-ring worn and leaking.	Replace.
Pump operates noisily.	Crankcase components worn excessively.	Inspect and replace if necessary.

MAINTENANCE

PREPARATION FOR STORAGE

Store the planter in a dry sheltered area if possible.

Remove all trash that may be wrapped on sprockets or shafts and remove dirt that can draw and hold moisture.

Clean all drive chains and coat with a rust preventative spray, or remove chains and submerge in oil.

Lubricate planter and row units at all lubrication points.

Inspect the planter for parts that are in need of replacement and order during the “off” season.

Make sure all seed and granular chemical hoppers are empty and clean.

D033009204

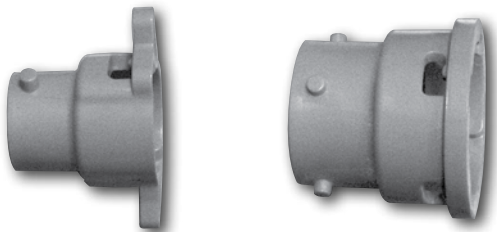

Remove seed discs from seed meters, clean and store meters in a rodent-free, dry area with discs removed. Store seed discs vertically on a dowel or pipe.

Remove vacuum hose from each seed meter. Operate the vacuum fan at full hydraulic flow from the tractor for two minutes to clear manifolds, hoses and fittings of dust and debris.

Clean breather on analog vacuum and pressure gauges.

Disassemble, clean and grease all U-joint slides.

Grease or paint disc openers/blades and row marker disc blades to prevent rust.

Flush liquid fertilizer tanks, hoses and metering pump with clean water. See “Piston Pump Storage” if applicable.

ASD System:

- Clean out ASD hopper, entrainment assembly, and delivery hoses.
- Disconnect delivery hoses from entrainer ports, install smaller orange caps onto ports, and attach hoses onto caps.
- Disconnect delivery hoses from air dissipator at each row unit, install larger orange caps, and attach hoses onto caps.
- Check that all bolts and fasteners used to assemble and attach entrainment device are tight (if applicable).
- Loosen knobs on entrainer cleanout doors to remove pressure from door gaskets.
- Inspect all seed delivery hoses and replace any that are worn, cut, or cracked.

MAINTENANCE

ELECTRICAL WIRING DIAGRAM FOR LIGHT PACKAGE

Machines Equipped With Double Light Assemblies

(A13037/A13037-1/A13037-2)

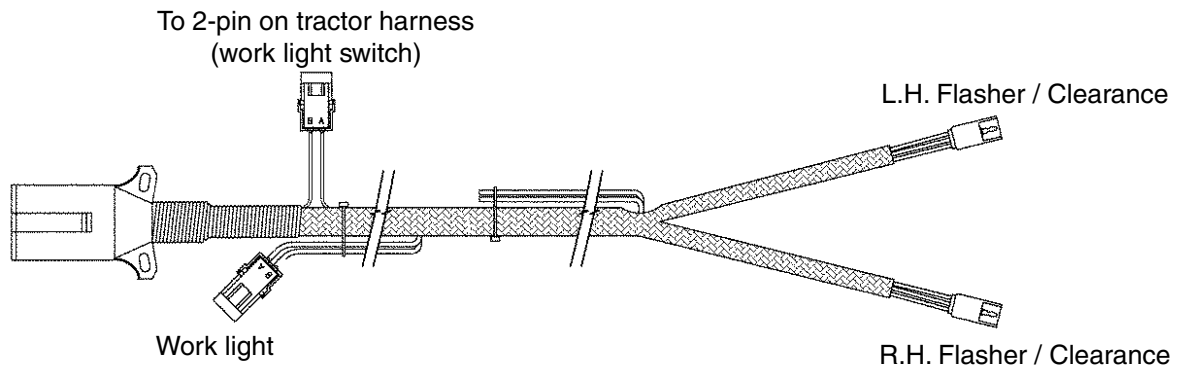
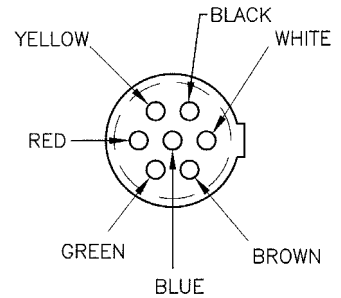
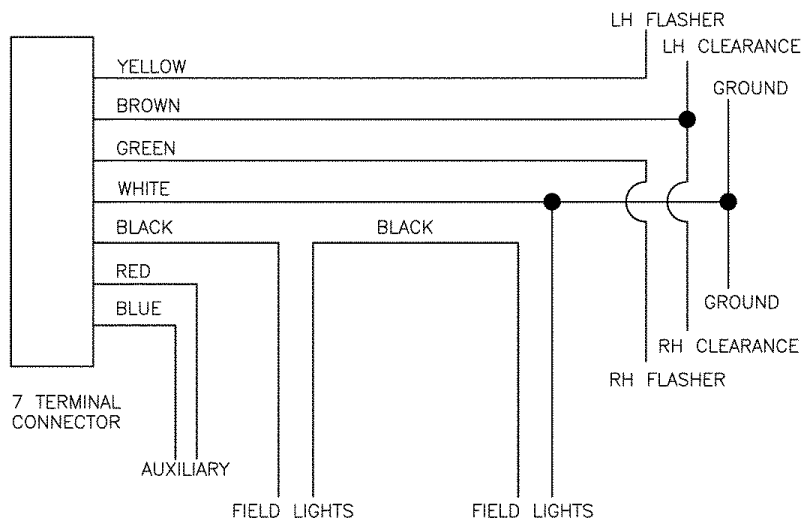

*** Optional customer-supplied auxiliary lights and wires may be wired into existing plug terminals.**

The light package supplied on the Model 3660 Twin-Line® Planter meets ASAE Standards. For the correct wiring harness to be wired into the lights on your tractor, check with the tractor manufacturer.

69922-35



MAINTENANCE

ELECTRICAL CONTROL CONSOLE SCHEMATIC

IMPORTANT: Before doing any electrical work, disconnect the control console from the tractor battery. Keep wiring harnesses away from high temperature areas or sharp edges. **DO NOT** route the wiring harnesses along battery cables. Use tie straps to keep wire harness away from moving parts on tractor and planter. Be sure ground connections to the tractor frame are clean to provide good electrical contact.

(A14012)

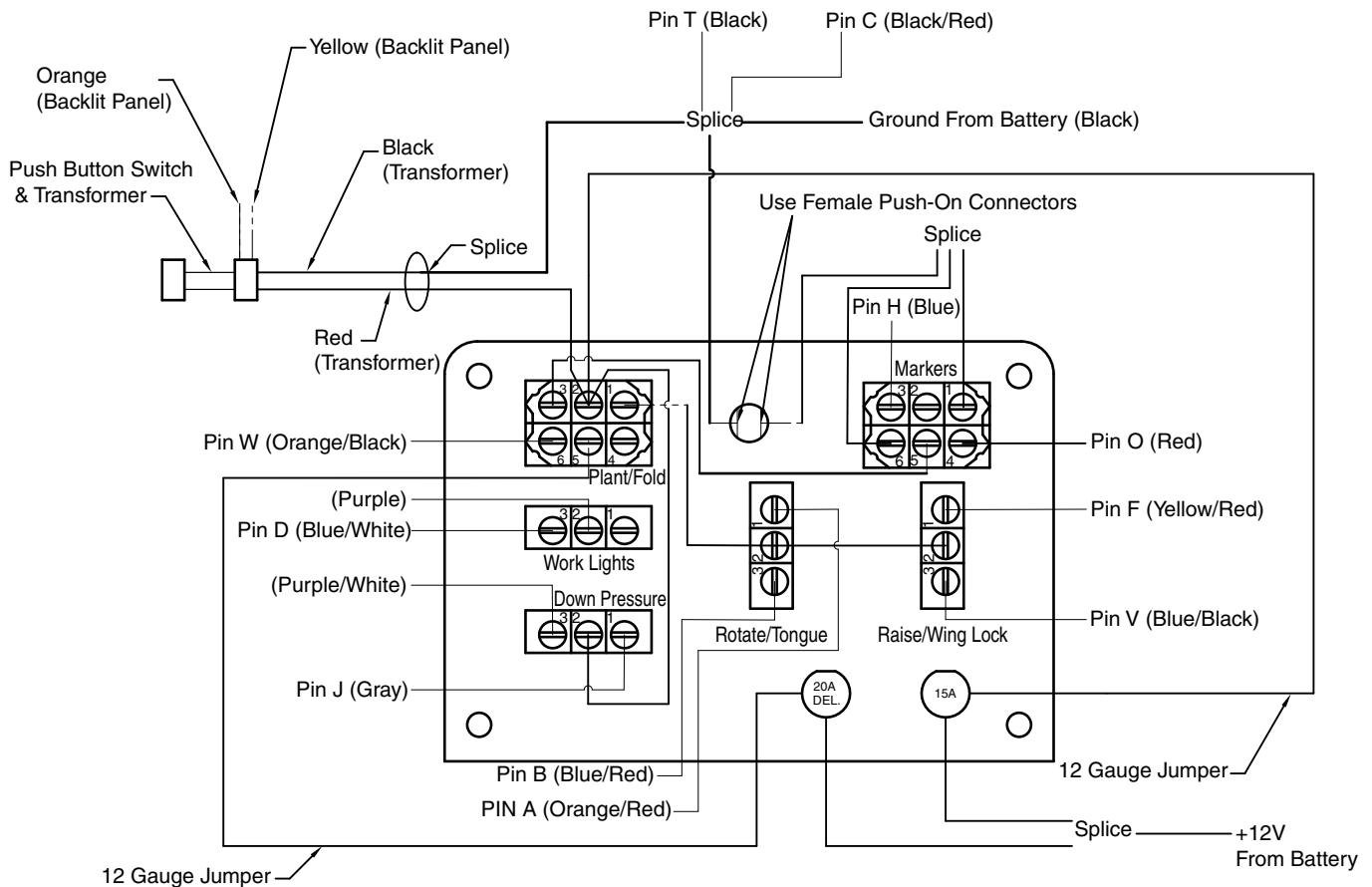
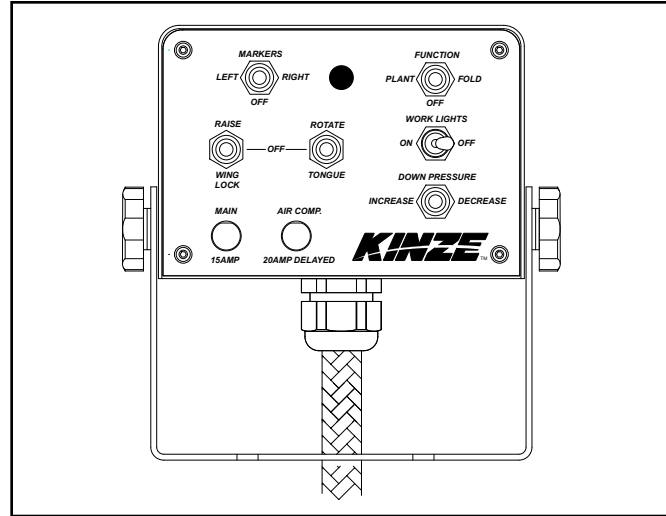

Rear View of Front Panel

MAINTENANCE

ELECTRICAL WIRING HARNESS SCHEMATIC (ON TRACTOR)

(A13036)

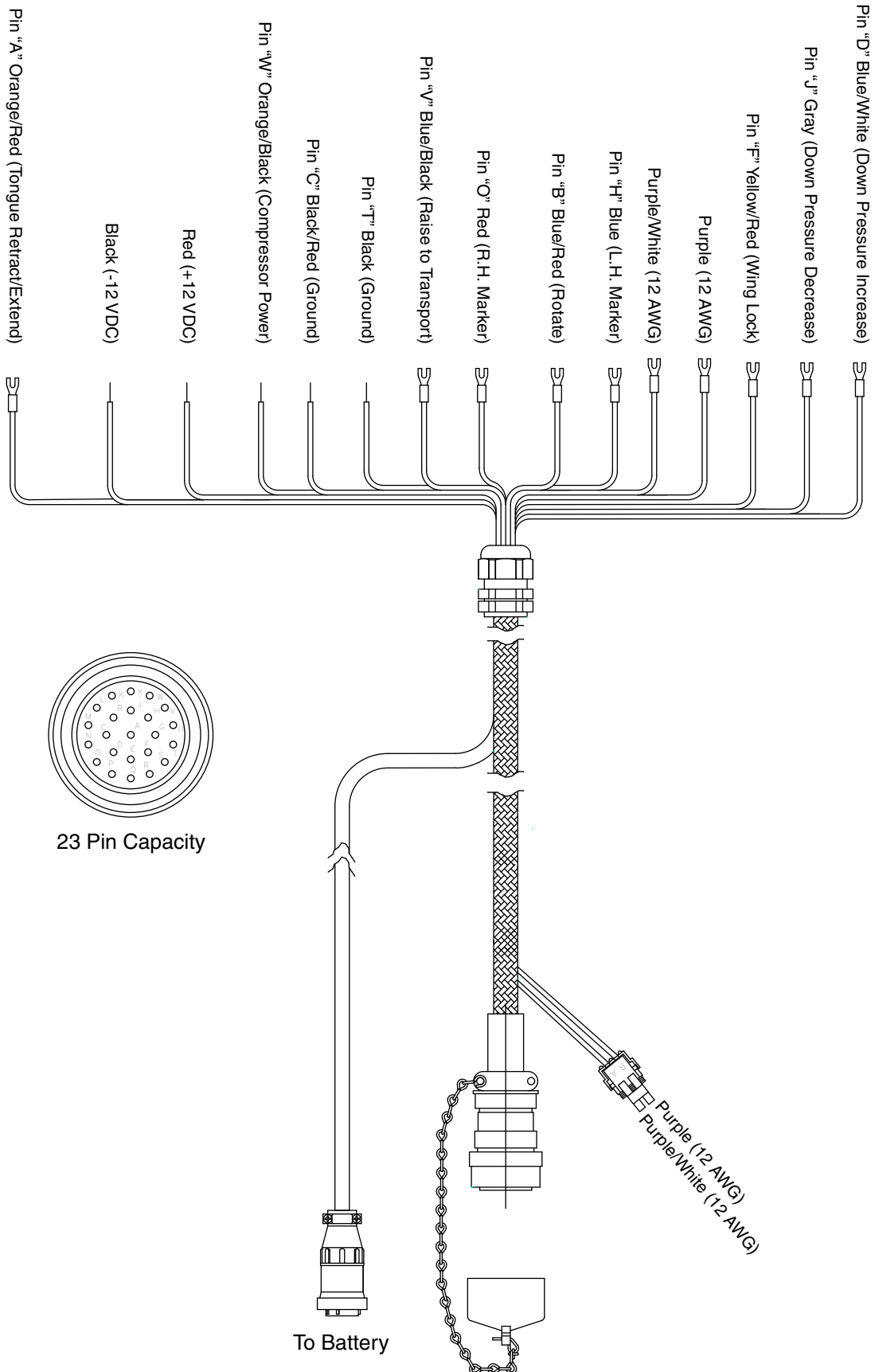

MAINTENANCE

ELECTRICAL WIRING HARNESS SCHEMATIC (ON PLANTER)

(A13035)

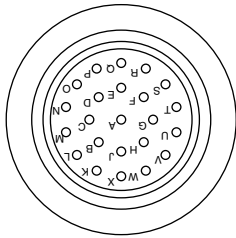

23 Pin Capacity

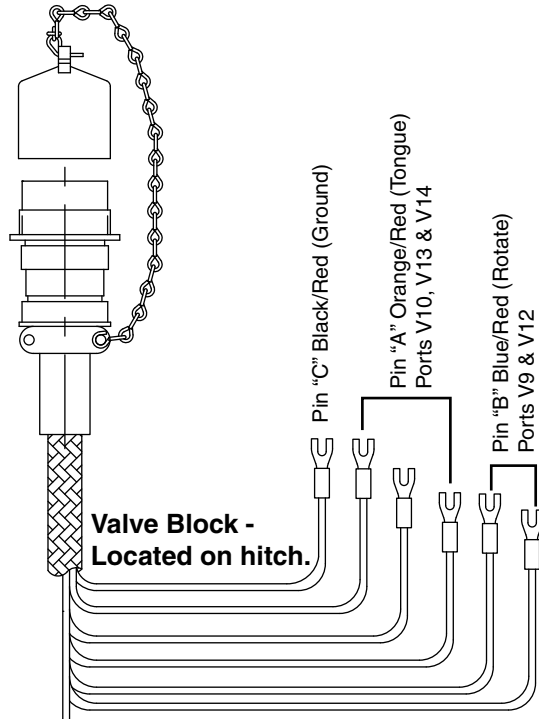

Valve Block - Located on hitch.

Valve Block - Located on rear center frame.

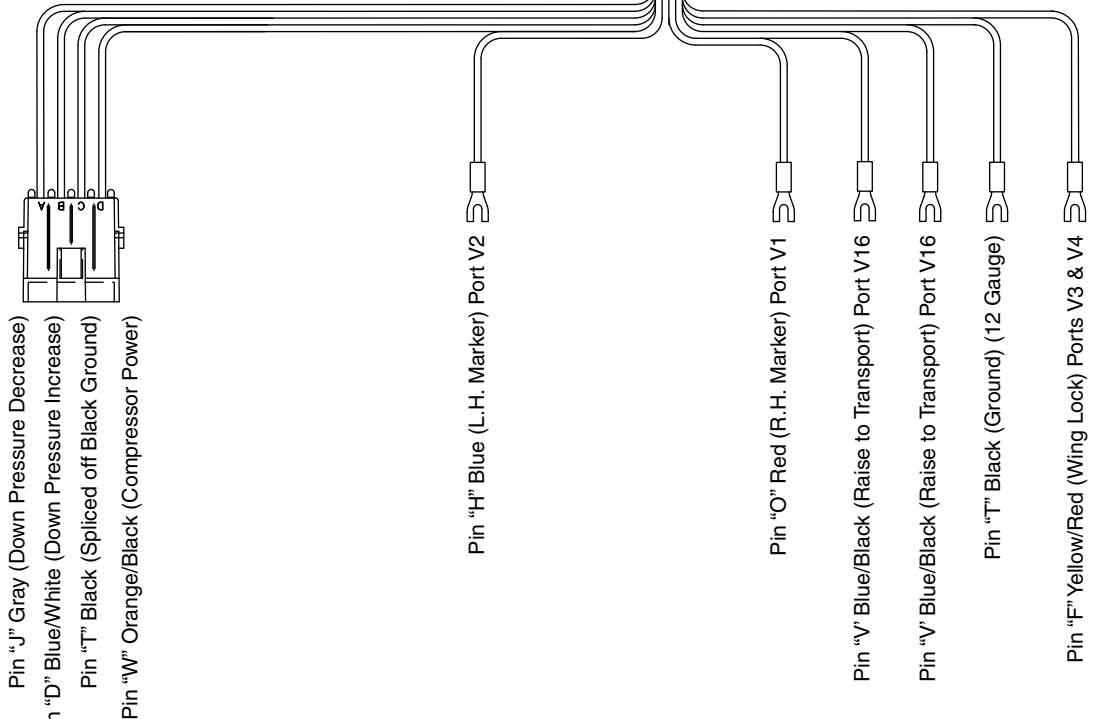

- Pin "J" Gray (Down Pressure Decrease)
- Pin "D" Blue/White (Down Pressure Increase)
- Pin "T" Black (Spliced off Black Ground)
- Pin "W" Orange/Black (Compressor Power)

Pin "H" Blue (L.H. Marker) Port V2

Pin "O" Red (R.H. Marker) Port V1

Pin "V" Blue/Black (Raise to Transport) Port V16

Pin "V" Blue/Black (Raise to Transport) Port V16

Pin "T" Black (Ground) (12 Gauge)

Pin "F" Yellow/Red (Wing Lock) Ports V3 & V4

MAINTENANCE

VALVE BLOCK - LOCATED ON HITCH

(A7012a)

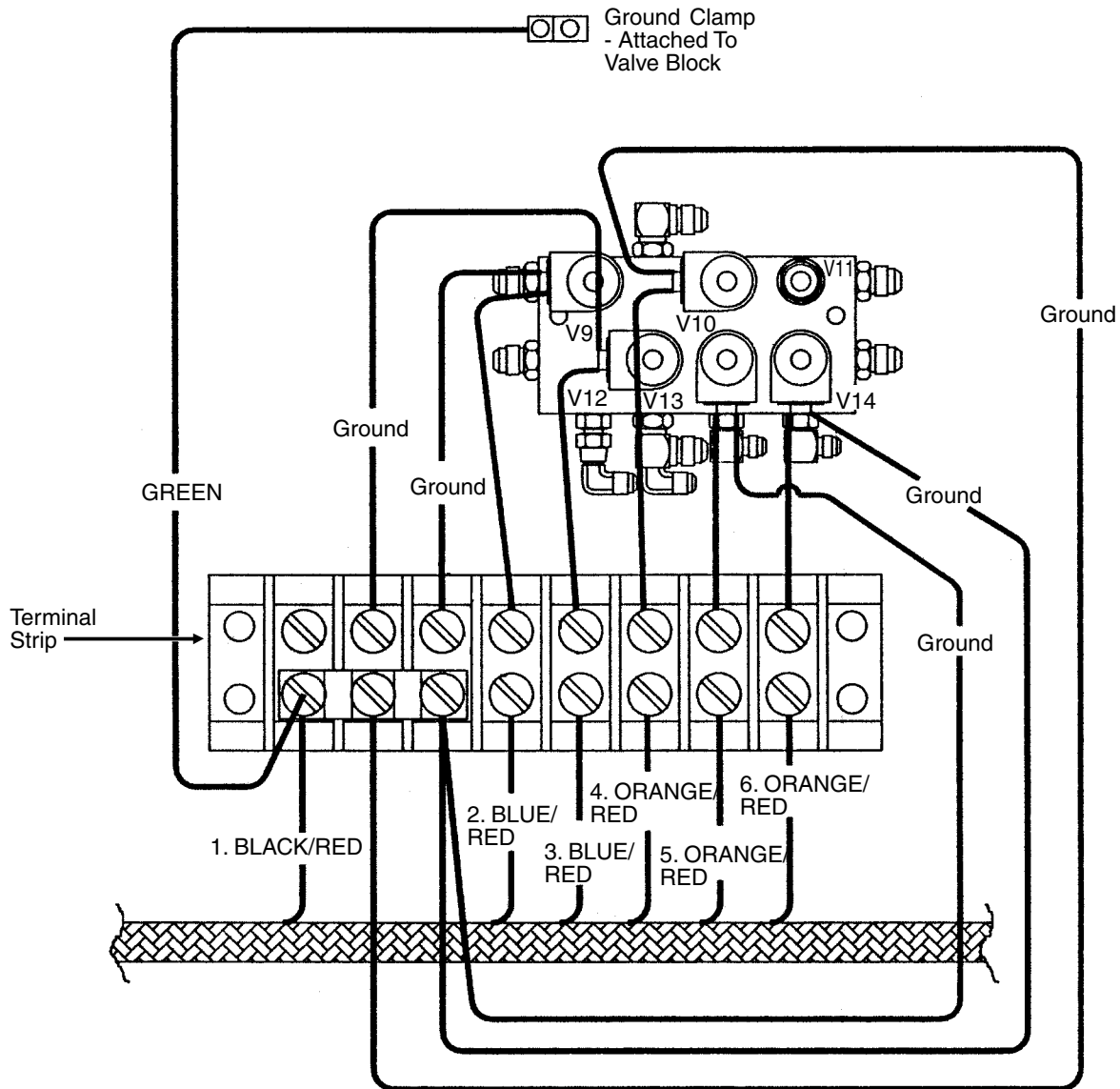

1. BLACK/RED - Pin "C" (Ground)
2. BLUE/RED - Pin "B" (Rotate) - Port V9
3. BLUE/RED - Pin "B" (Rotate) - Port V12
4. ORANGE/RED - Pin "A" (Tongue) - Port V10
5. ORANGE/RED - Pin "A" (Tongue) - Port V13
6. ORANGE/RED - Pin "A" (Tongue) - Port V14

MAINTENANCE

VALVE BLOCK - LOCATED ON REAR CENTER FRAME

(IP1078)

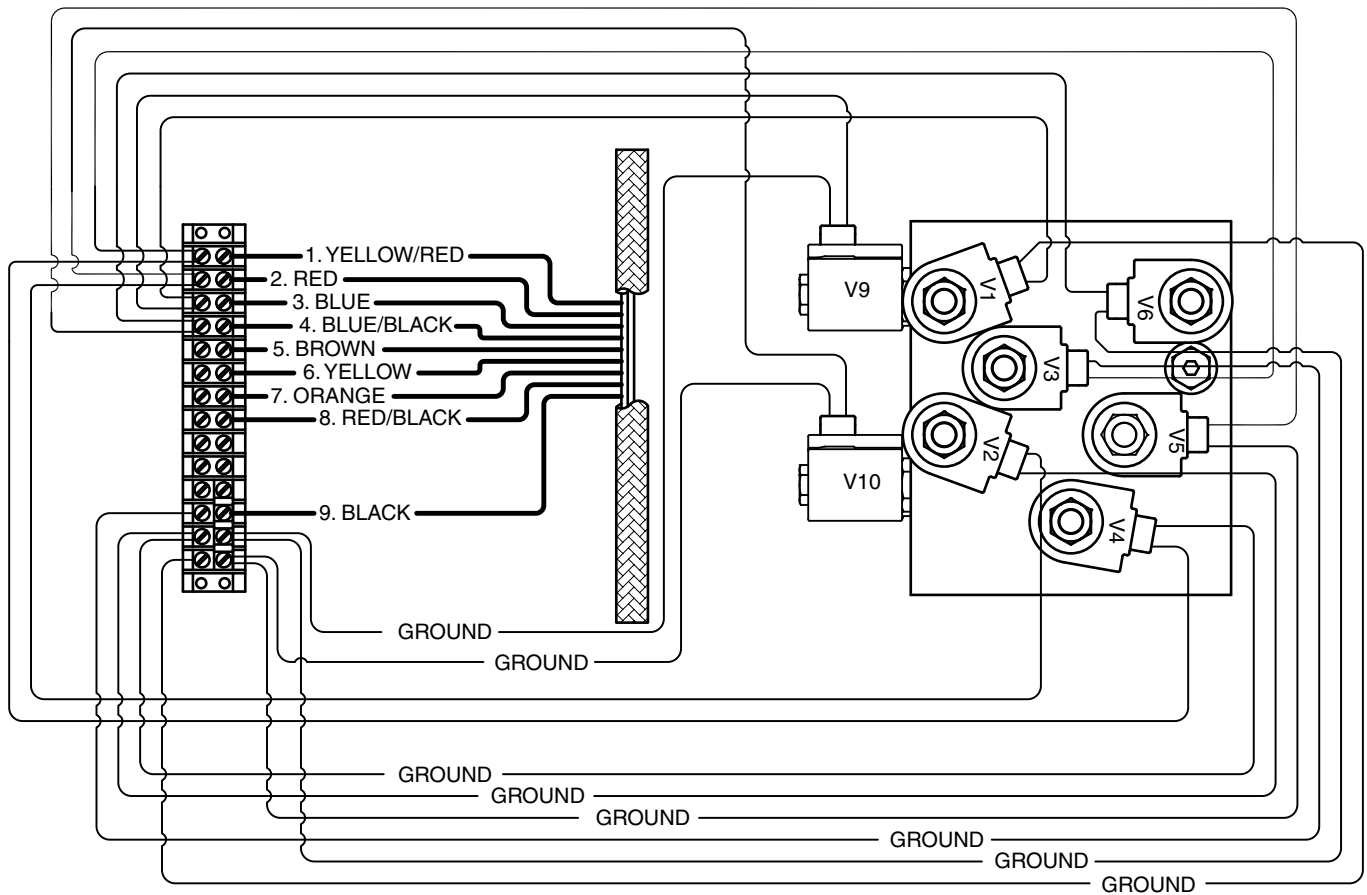

1. YELLOW/RED - Pin "F" (Wing Lock) - Ports V3 & V4
2. RED - Pin "O" (R.H. Marker) - Ports V2 & V10
3. BLUE - Pin "H" (L.H. Marker) - Ports V1 & V9
4. BLUE/BLACK - Pin "V" (Raise To Transport) - Ports V6 & V5
5. BROWN - Pin "R" (L.H. Point Row Clutch)
6. YELLOW - Pin "S" (L.H. Two-Speed Clutch)
7. ORANGE - Pin "G" (R.H. Point Row Clutch)
8. RED/BLACK - Pin "U" (R.H. Two-Speed Clutch)
9. BLACK - (Monitor Ground) - Port V3

MAINTENANCE

HYDRAULIC SYSTEM SCHEMATIC

(IP1055b/TWL111)

16 Row Shown (Two Wing Lift Cylinders Per Wing)

12 Row (One Wing Lift Cylinder Per Wing)

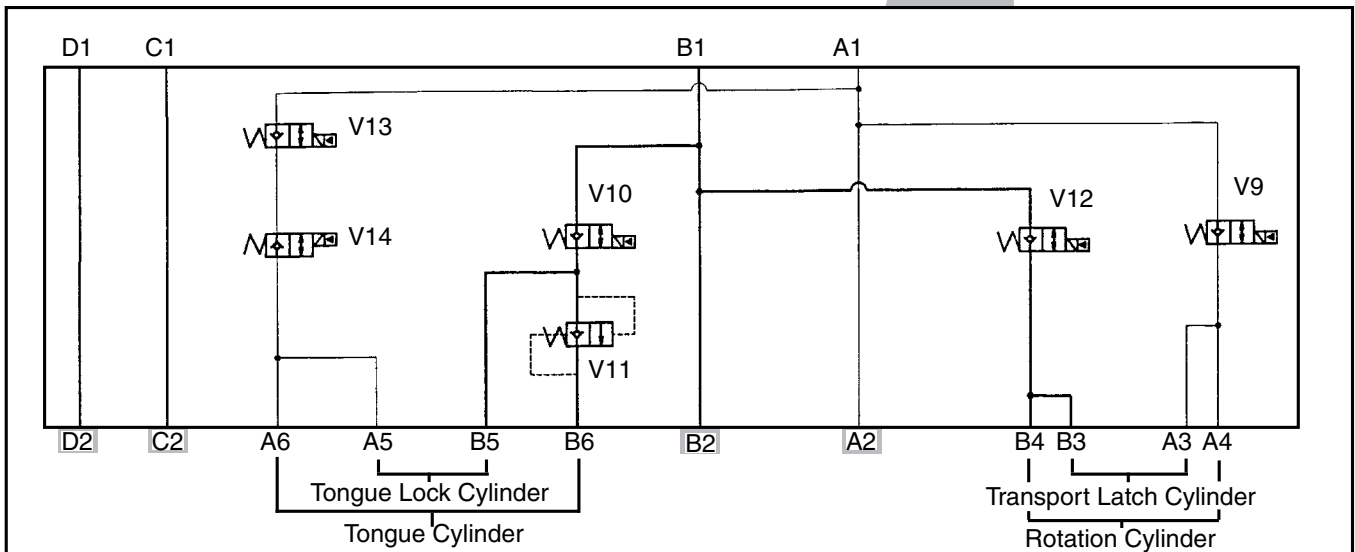
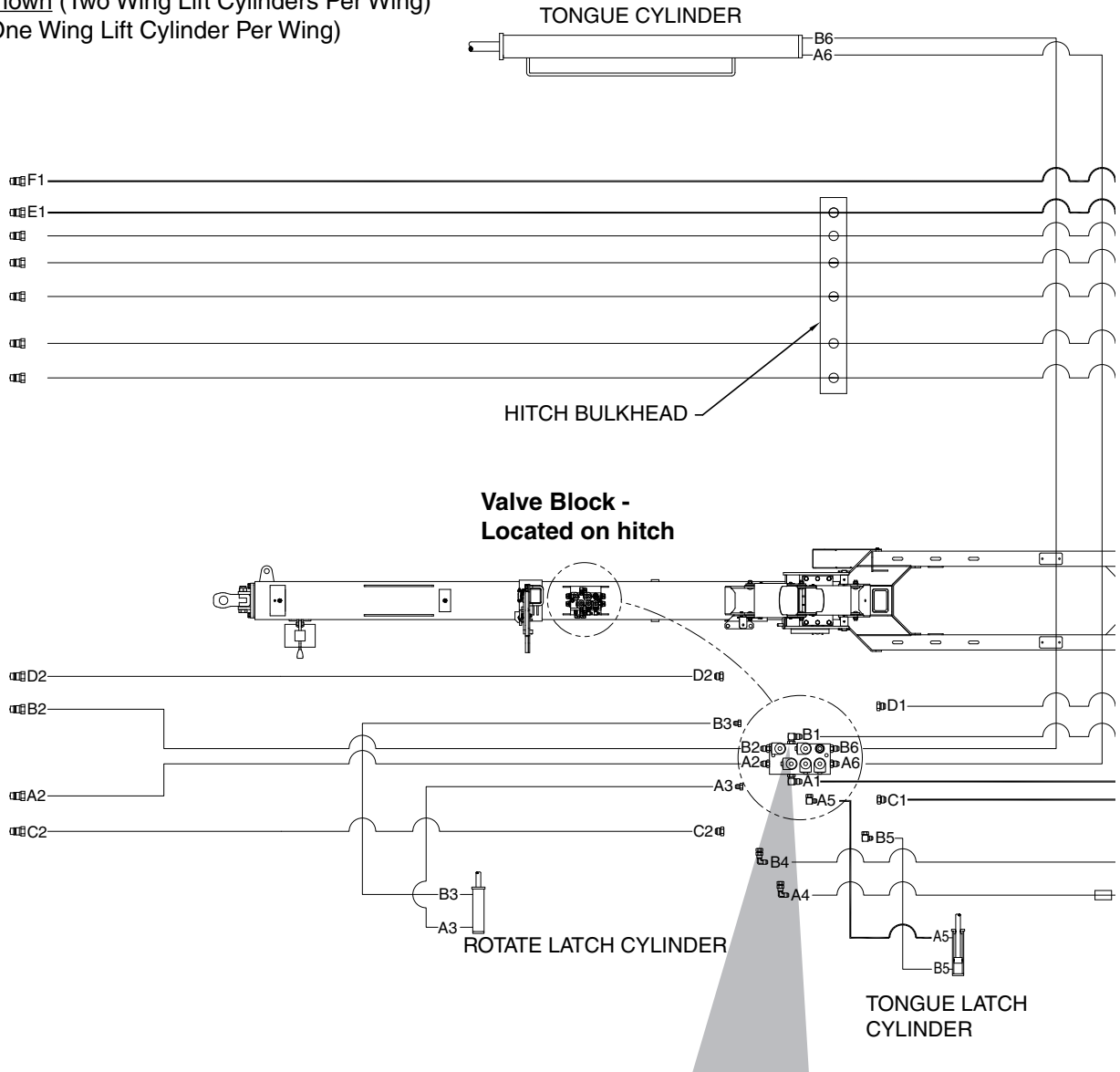

MAINTENANCE

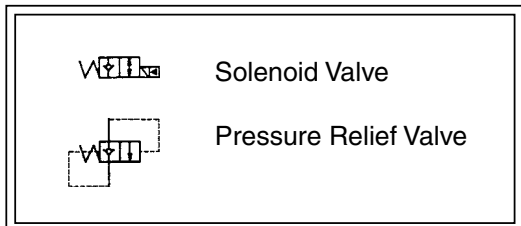
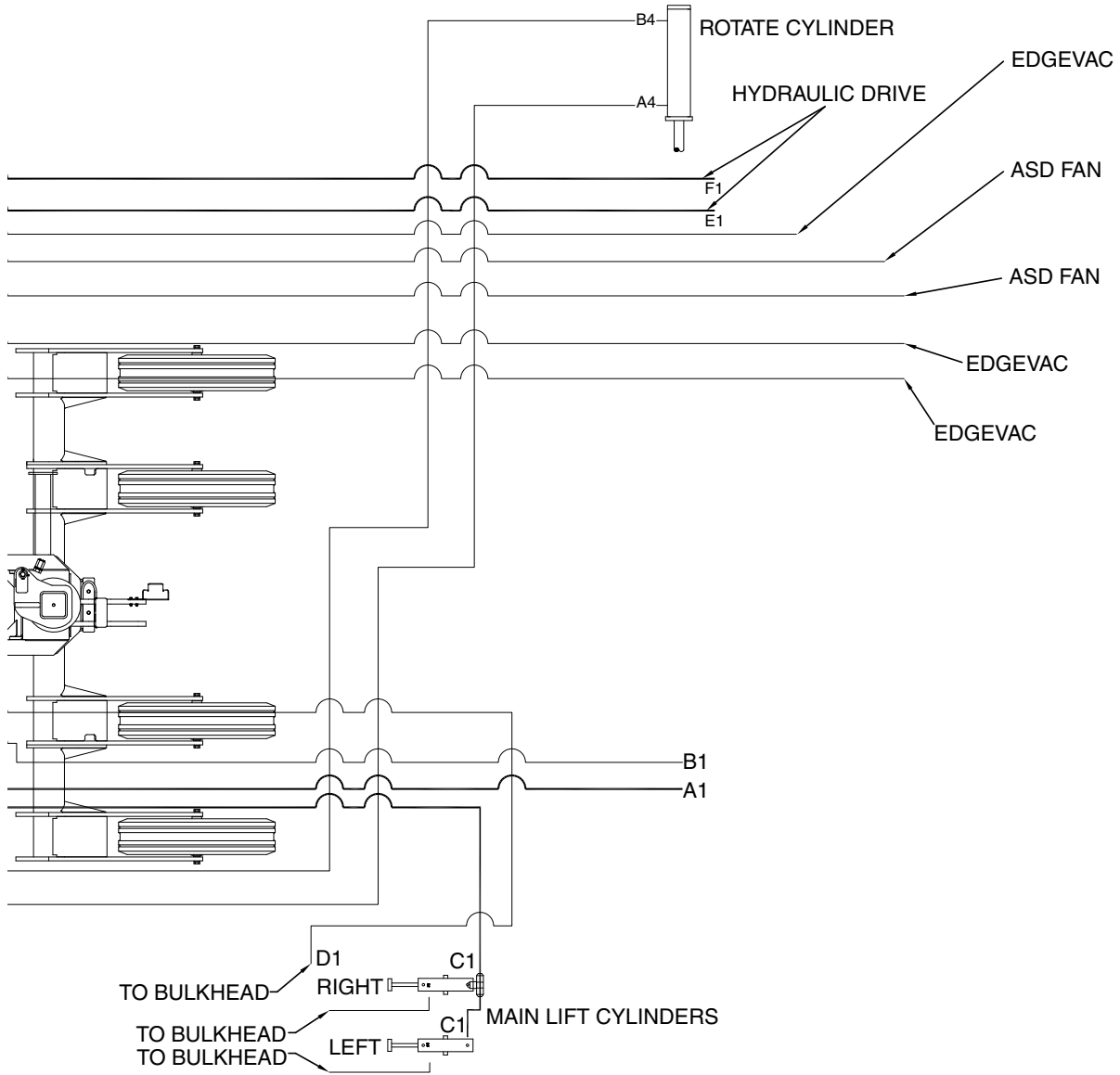

MAINTENANCE

HYDRAULIC SYSTEM SCHEMATIC (Continued)

(IP1055c/IP1077/TWL114)

16 Row Shown (Two Wing Lift Cylinders Per Wing)

12 Row (One Wing Lift Cylinder Per Wing)

NOTE: See R.H. Marker Assembly for additional information.

RIGHT MARKER CYLINDER

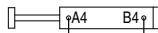

Valve Block - Located on rear center frame

TRANSPORT/LIFT CYLINDER

F2

E2

RIGHT DOWN PRESSURE CYLINDER

F3

E3

RIGHT WING LOCK CYLINDER

C1

D1

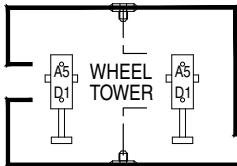

WHEEL TOWER

A5

Q1

A5

Q1

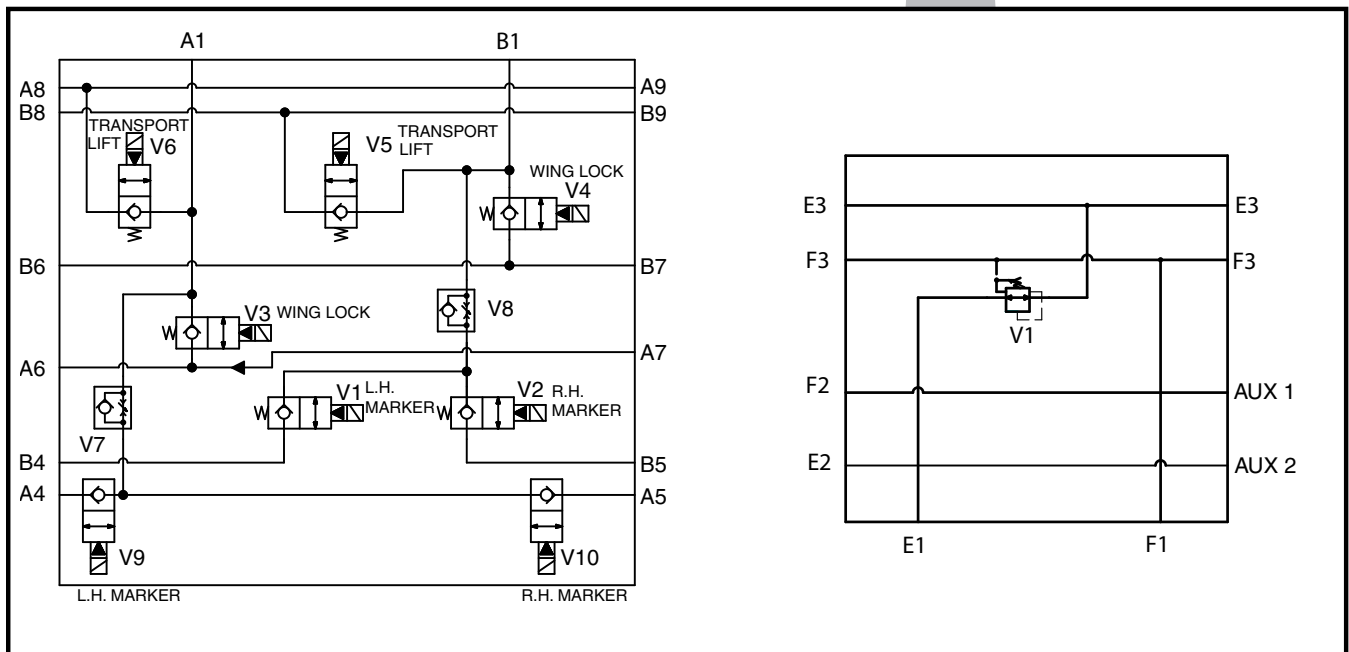
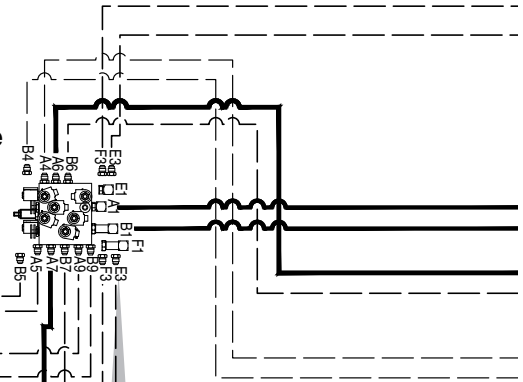

MAINTENANCE

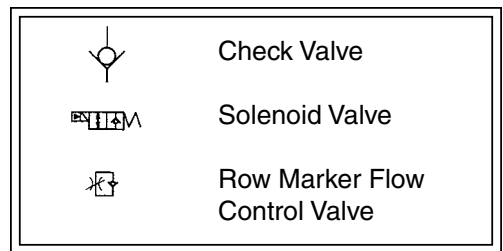
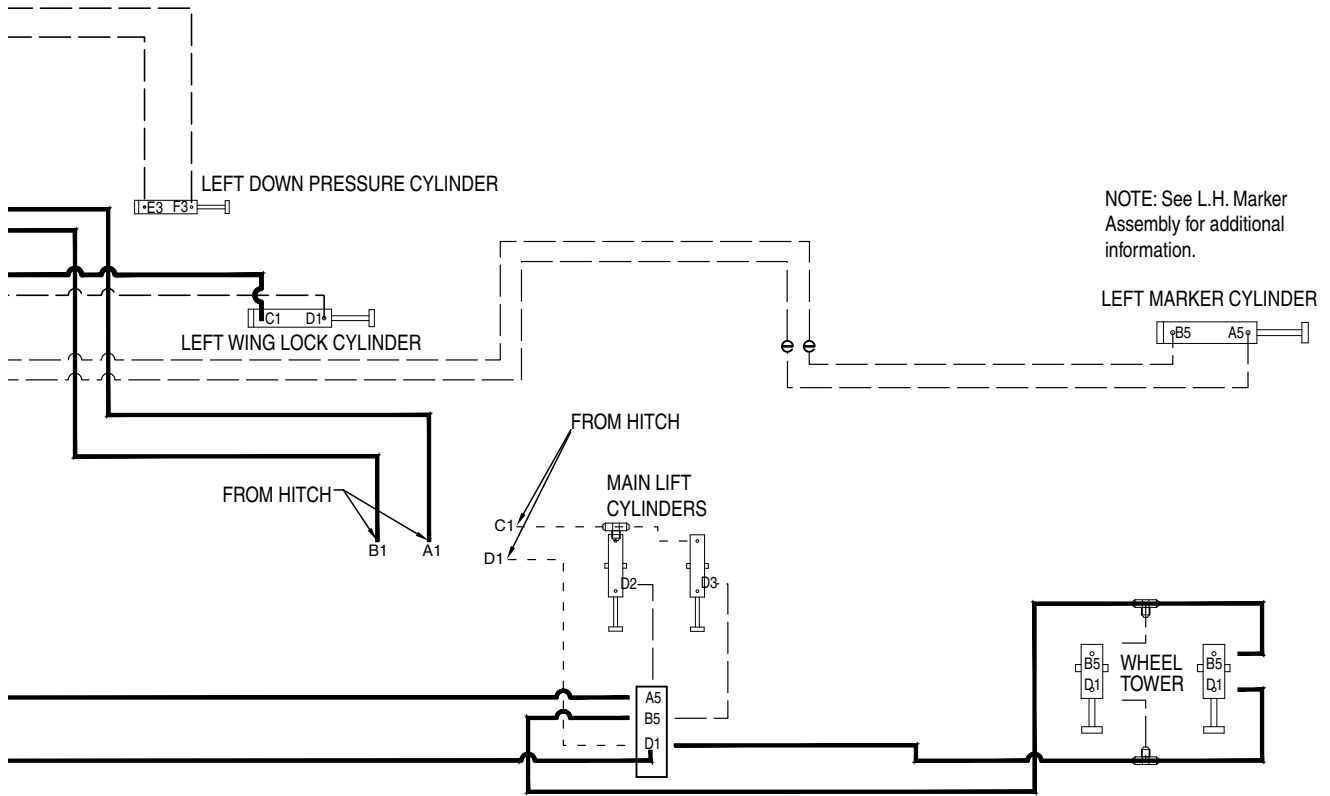

MAINTENANCE

HYDRAULIC SCHEMATIC - VACUUM FAN MOTOR SYSTEM

(IP1063)

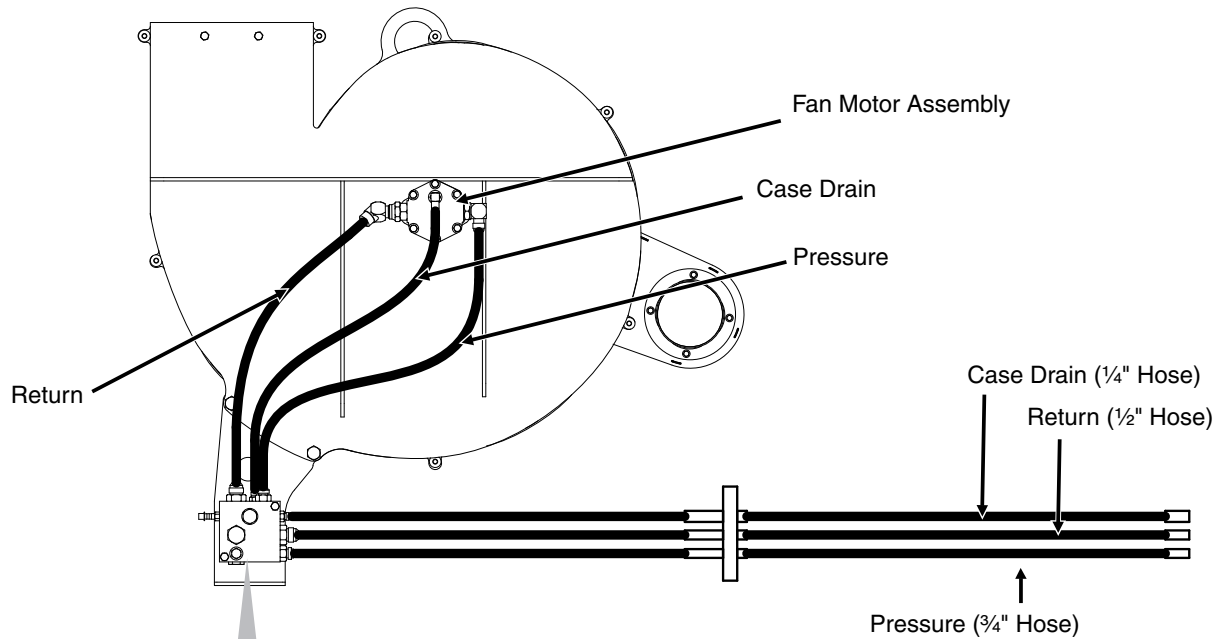

A11068bb

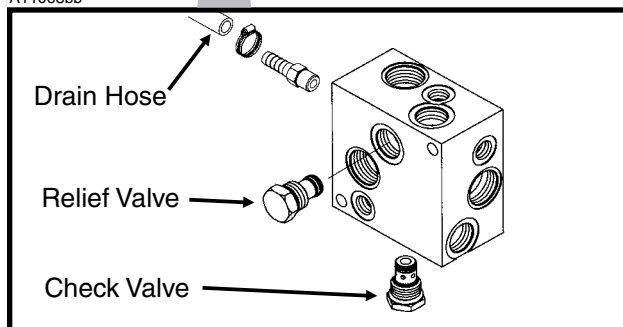

Vacuum Fan Motor Valve
Block Assembly
(See Machine Operation
Section)

IMPORTANT: Connect hydraulic motor case drain to a case drain return line with zero pressure on the tractor. Failure to connect to a return with zero pressure will cause damage to the hydraulic motor. DO NOT connect hydraulic motor case drain to SCV outlet. Contact tractor manufacturer for specific details on "zero pressure return".

MAINTENANCE

HYDRAULIC SCHEMATIC - OPTIONAL PTO PUMP DRIVE AND OIL COOLER SYSTEM (TRACTOR MOUNTED)

(TWL290c/IP1057)

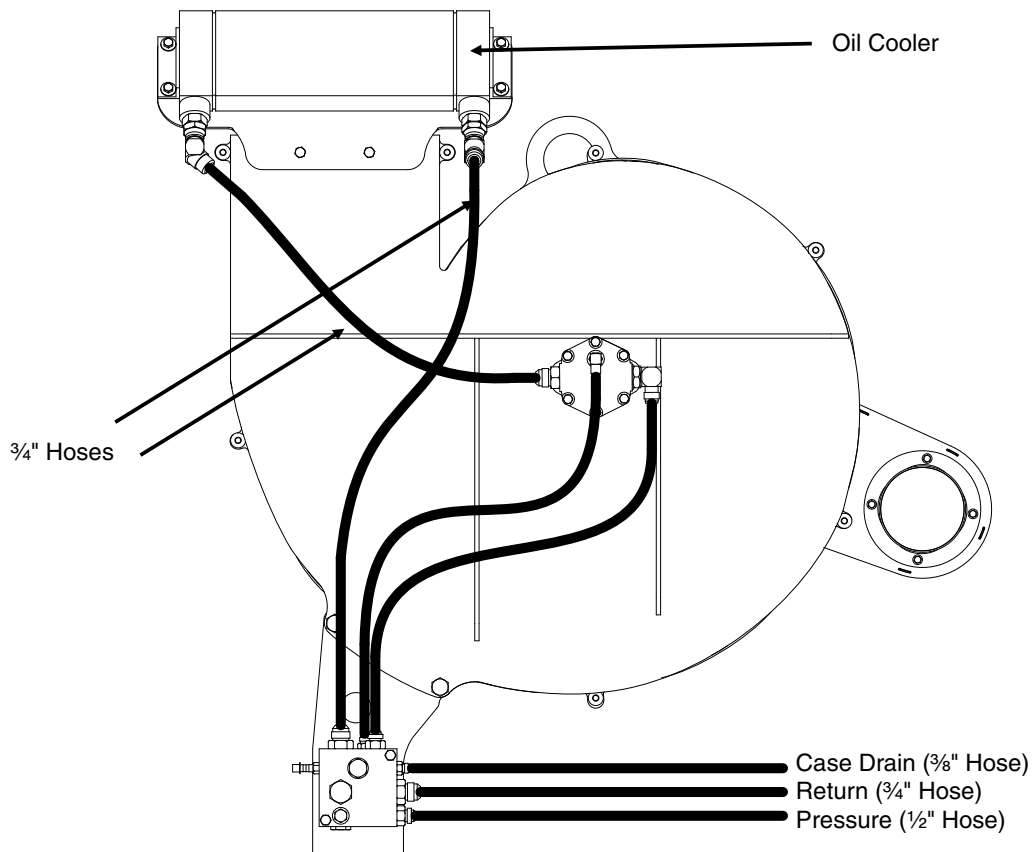
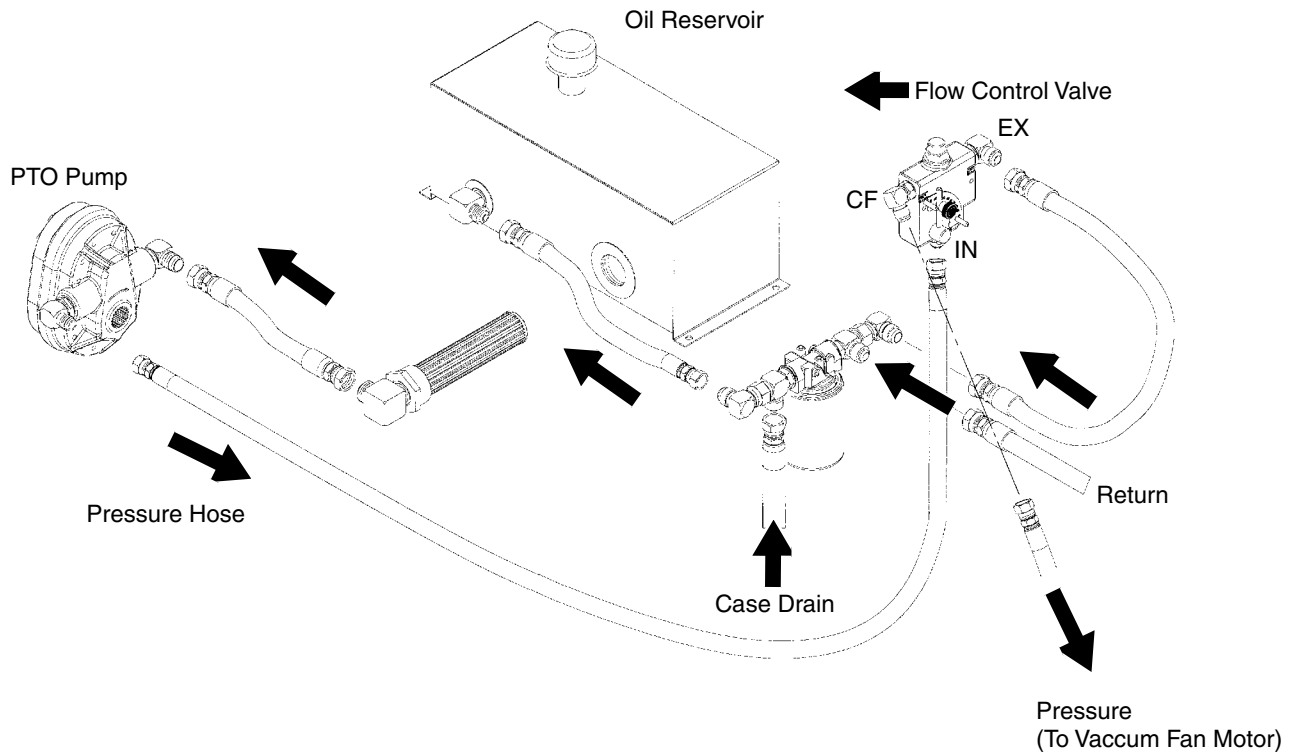

MAINTENANCE

HYDRAULIC SCHEMATIC - OPTIONAL PTO PUMP DRIVE AND OIL COOLER SYSTEM (PLANTER MOUNTED)

(IP1059/TP1010)

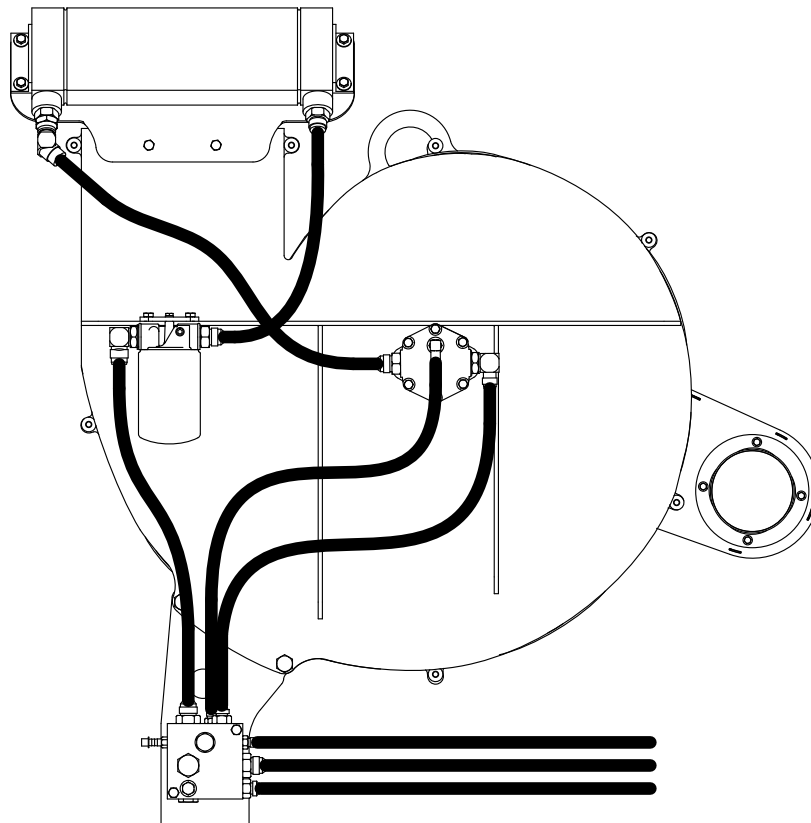
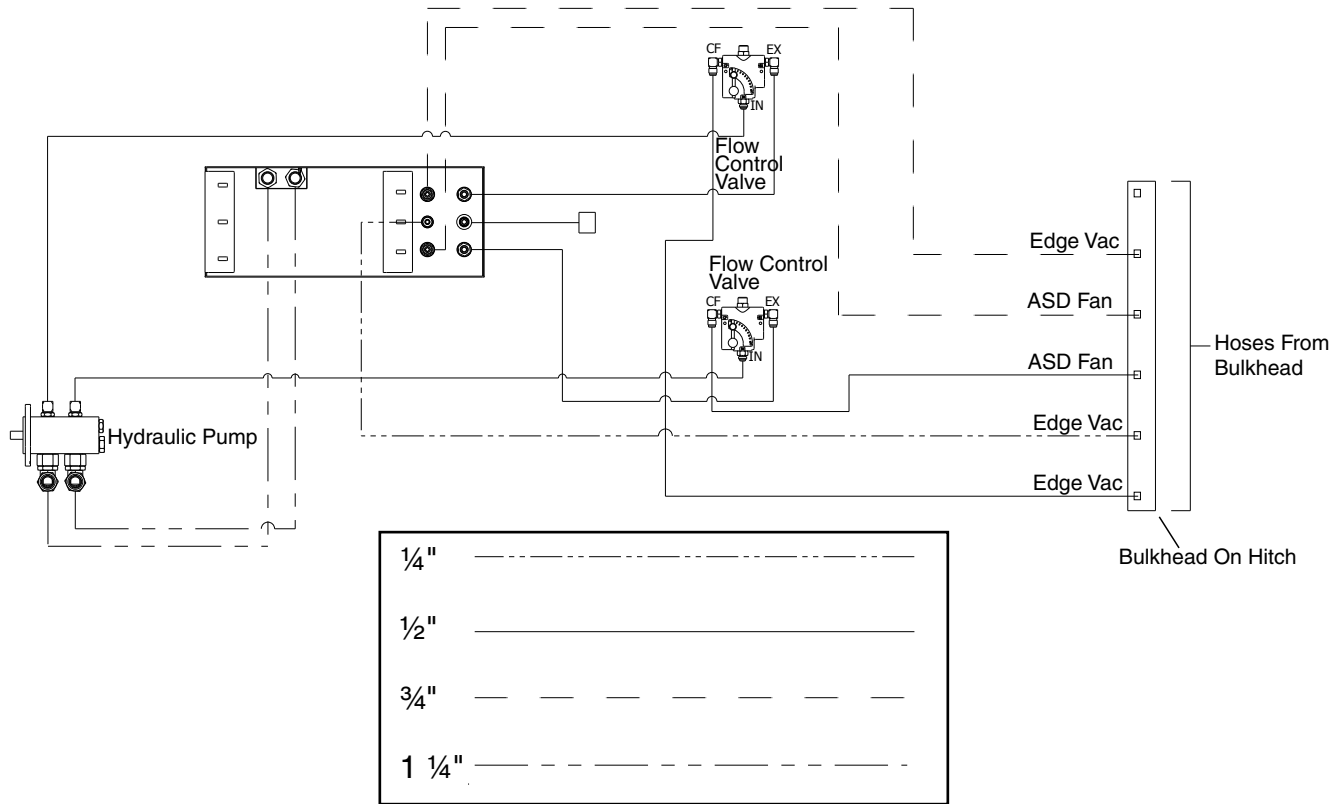

MAINTENANCE

AIR LINE SCHEMATIC WITH INTERPLANT

(TP1005)

16 Row Shown

Front

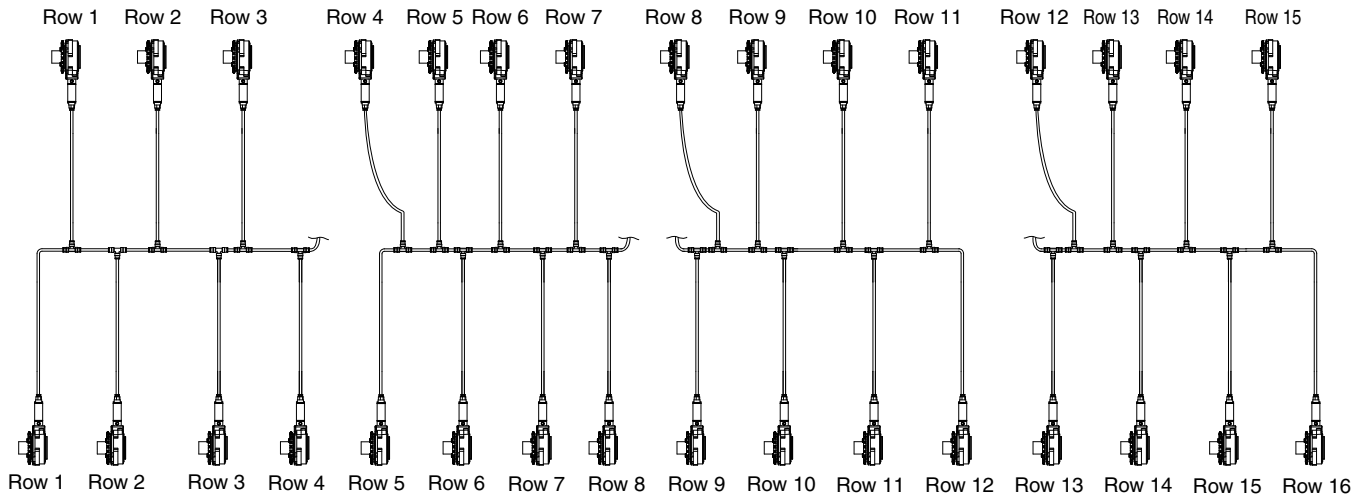

Rear

MAINTENANCE

This page left blank intentionally.